



SHIRE OF WICKEPIN REQUEST FOR WALGA E-QUOTE

REQUEST FOR QUOTATION

Supply & Delivery of One (1) Truck Tipper GVM 6,500 KG

Request for Quotation (RFQ)	<i>Supply & Delivery of One (1) Truck Tipper GVM 6.500 KG</i>
------------------------------------	---

Deadline	4pm Friday 30 th October 2020
-----------------	--

Address for Delivery	SHIRE OF WICKEPIN WOGOLIN ROAD WICKEPIN WA 6370
-----------------------------	---

E-Quote Number	RFQ-6
-----------------------	-------

SHIRE OF Wickepin

REQUEST FOR QUOTATION

Supply & Delivery of One (1) Truck Tipper GVM 6500 KG

SCOPE OF QUOTATION

1. DESCRIPTION OF ITEM

The supply and delivery of One (1) New Truck Tipper GVM 6500 KG

The new machine shall be supplied to the Shire of Wickepin and shall conform to the following specifications and conditions. Submissions shall include in full and complete details of all specifications and features regarding the vehicle offered.

The quotation includes the trade-in of the Shire's current 2015 Hino Truck. Detail of this machine is given in Clause 7. The Council is offering this machine as a trade-in.

2. SPECIFICATIONS

2.1 General Specifications

The machine shall comply with the following specifications.

1. Operating Weight – 6500 KG GVM The machine must be suitable for full road registration in Western Australia.
2. The machine's maximum width is such that it will not be considered over width for registration or transport purposes. It must be approved for day and night operation.
3. Engine – Diesel powered with a minimum rating of 110 Kw to 140 Kw. Engine must be compliant with emission requirements.
4. Double element air cleaner .
5. End tip operated form cab of tuck
6. Hydraulic Hoist Ram capable to lift 10 ton
7. Tool Box to fitted between cab and tipper 2400mm L x 500mm W x 500mm H Lid type door hinged on the rear side box lid opening pass 110 degrees so it sits open against tipper body
8. Rear tailgate be able to swing and to be able pined to the side and removable . In rear tipper mode tailgate is have a release system by air ram operated form cab of tuck
9. Tipping body 3600 mm long by 2400 mm wide with drop sides at 450mm in depth and tie rail under the body

10. The height of tray floor from ground to be 1m
11. Tow point 50 mm ball
12. Seven pin plug round small
13. External Sun visor & stone guard
14. Master switch electrical disconnect and emergence stop.
15. Spare tyre and rim to be fitted .
16. Operators cab to have factory integrated air conditioning. Fully adjustable suspension seat, adjustable steering wheel and or column, tinted windows, suitable access for 12v power output for two-way radios etc. and noise levels for the operator below 78db.
17. Radio CD USB player, to be fitted with aerial & 80ch uhf radio to be fitted with aerial
18. Canvas heavy-duty seat covers.
19. Reversing alarm and camera to be fitted.
20. Fuel tank to be minimum 200 + litres.
21. Flashing beacon LED and to meet work safe standards x 2 to be fitted left and right side of roof of cab .
22. Parts manuals.
23. Workshop manuals.
24. Operators manuals.
25. Two set of keys.

2.2 Additional Information

The specifications listed above to be taken as minimum criteria only. Submissions that exceed or come under these specifications will still be considered and determined by the works manger if they are accepted or not

Suppliers are requested to ensure quote includes the above items:

3. REGISTRATION DETAILS

The machine shall be licensed to the 30th June 2020. All costs associated with the registration of the vehicle will be met by the supplier. Council wants to retain original number plates which is on the current truck plate change on the day of delivery will be needed this is a part of associated cost

4. DELIVERY AND INSPECTION

The supplier shall supply a date for the delivery of the new truck completed to specification's and offered and ready for immediate use at the Shire of Wickepin's depot.

Suppliers shall take into account any possible delay in delivery of the new machine and factor this into their price. Council will not be liable for price increases or wear and tear on the trade-in machine should an extended delay in delivery be encored.

If requested, the supplier shall make the machine offered in their submission available for a demonstration and/or inspection by Council's Works Manager prior to the acceptance of any quote.

The machine will be deemed as accepted when the Works Manager or his representative has inspected it, completed all operating tests and is satisfied that the machine is complete as specified and ready for immediate use.

5. PRODUCT WARRANTY

The supplier shall outline all warranty and defect replacement details with the submission of the quotation documents. Please note the option for pricing on an extended warranty.

6. PRODUCT STANDARD

The product will be to a standard all relevant specifications and standards currently in place in Western Australia. At the request of the Works Manager the contractor will supply appropriate details to confirm and verify the product standard in accordance with those specifications.

7. TRADE-IN MACHINE

The machine offered for trade-in in this quotation is a 2015 Hino Tare 3500kg AGG 6500 kg GVM the current kilometres are 81636. This machine is offered on a 'as is where is' basis. Inspection of the machine can be arranged by contacting Council's Works Manager, Gary Rasmussen on 0429 882 871.

Council will continue to utilise the trade-in machine until the replacement machine is supplied and accepted. It is the responsibility of the supplier to price in a factor for usage in that above-mentioned period.

8. SELECTION CRITERIA

The following criteria will be taken into consideration in determining the successful Supplier:

- Price.60%

- Demonstrated experience with after sales support and on-site service of the machine. 10%
- Operators feedback form demonstration up to 30%

Please note that the Shire of Wickepin will not be submitting a price for any part of this quote as per the *Local Government (Functions & General Regulations) Clause 14(4) (d)*.

9. LODGEMENT/ACCEPTANCE OF QUOTE

Quotes are to be no later than 4pm Friday 25th October 2019 .

Council shall not be bound to accept the lowest or any quotation.

The quote is deemed to be accepted when Council emails written notification of such acceptance to the successful Supplier.

Price Schedule

All pricing must include GST.

QUOTATION

New Truck type & body plus toolbox	Price ex GST	Price gst
HINO 721 AT 3500	86,350.00	94,985.00
Trade in machine		
2015 HINO-WK698	29318.18	32,250.00
Total	57,031.81	62,735.00

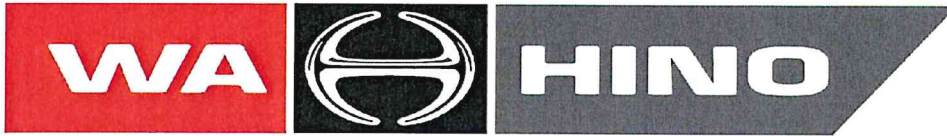

Vehicle Quotation

October 30th, 2020

SHIRE OF WICKEPIN
77 Wogolin Rd
Wickepin Wa 6370

PSP#: 20033
QUOTE#: Q24666

Thank you for the opportunity to provide you with the following quotation on a new vehicle and we look forward to your favourable reply.

We are sure that the following detailed specification will meet your operational requirements and I look forward to serving your business needs.

New Hino 300 Series 721 AT 3500 WIDE
Model: XJC710R-WKTOJO3

Vehicle Price	61,936.89
AUTO PTO EXCESS	1,200.00
PTO SWITCH/WIRING/ACTIVATION	850.00
EXTERNAL SUNVISOR	950.00
STONEGUARD	650.00
E-STOP EXTERNAL DRIVERS SIDE	420.00
BATTERY ISO SWITCH	460.00
WINDOW TINT	280.00
IN CAB 12V COIL FOR TWO WAYS	360.00
TX3500 UHF	810.00
CANVAS SEAT COVERS	380.00
REV ALARM AND CAMERA	Included
200LT DIESEL TANK	Included
WORKSHOP AND PARTS MANUALS	3,100.00
BODY BY ROLSTEEL	24,430.00

Sub-Total	95,826.89
DISCOUNT	9,476.89 -

Sub-Total	86,350.00
Dealer Delivery	Included
GST	8,635.00

Vehicle Total	94,985.00
Less Settlement	
Trade in: WK698:300 SERIES New Hino 300 Series 717	
Mediu	32,250.00 -

Total Amount Payable	62,735.00
-----------------------------	-----------

Additional Items for Consideration

OPT--5YR/250,000KM FACTORY WARRANTY	2,500.00
OPT--BENGINEERING BODY--DEDUCT NOT CONFORMING	1,890.00 -
OPT---P&G BODY	480.00
OPT--OMB BODY	2,145.00

PLEASE NOTE:

This quote is valid for 30 days.

PLEASE ALSO NOTE:

The Manufacturer's warranty covers the Chassis only. All bodybuilds/ ancillary fitments are provided by third parties on the customer's instructions and are entirely at the customer's risk. The customer may have rights against third parties subject to their warranty provided.

FINANCE & INSURANCE

We have a qualified Business Manager, who has access to daily rates which provides us with the opportunity to secure for you the best possible funding package.

Justin Ward is available to discuss the various options and can, if required, design a package to best suit your your requirements.

I hope the above quote meets your expectations and look forward to speaking to you soon. Please do not hesitate to contact me should you have any queries.

HINO & THE TOYOTA GROUP:

Under the Hino brand, we represent the Toyota Group in the global global market for heavy-duty trucks and buses. We also produce Toyota-badged vehicles on commission, including Toyota's popular sport-utility vehicle, the 4Runner, Dyna trucks, and Toyoace commercial vehicles. We use the Toyota Production System to achieve continuing gains in productivity and in quality throughout our operations. We have adapted that system to our model line to offer our customers the best-possible products at competitive prices. Our operations are growing globally in step with the globalization of the Toyota Group.

PARTS & SERVICE:

We at WA Hino Sales & Service offer you our full Service and Spare Parts facilities, which have a reputation second to none. Our normal trading hours in the Service Centre are 7.30am to 11.30pm Monday through Friday, also Saturday mornings.

Yours sincerely,

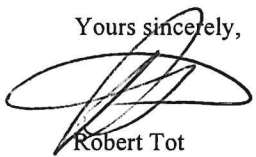

Robert Tot
Fleet Sales Consultant



Paul McGovern
Dealer Principal

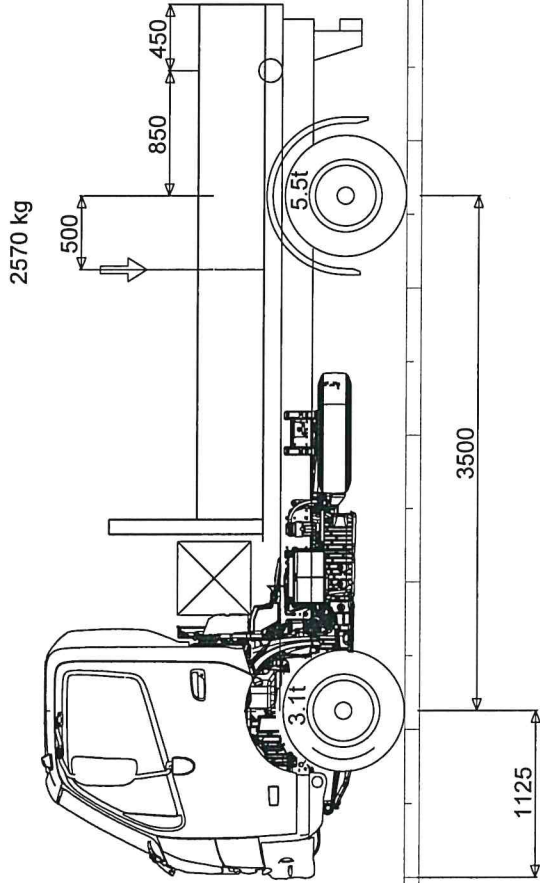
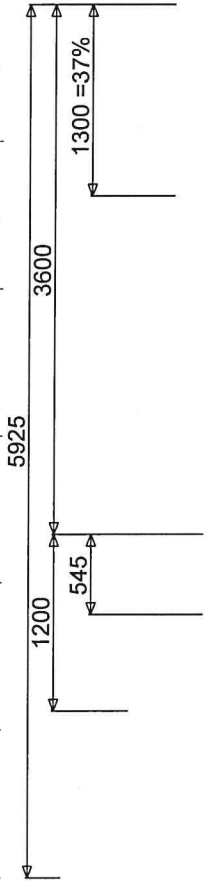

= 3930 kg
= 6500 kg
= 6500 kg

△ 1686
3889
5500

Unloaded △ 2244 { 57% }
loaded 2611 { 40% }
Max 3100

HINO 300 - 721 AT 3500 Medium_721

WA Hino Sales & Service 24-26 Kewdale Road Welshpool, WA 6986

HINO 300 - 721 AT 3500 Medium_721

Wheelbase	mm	3500
Front overhang	mm	1125
measurement: front axle-rear of cab	mm	655

	x CoG	Fa	Ra	Total
+ Chassis weight		1950	970	2920
+ number of persons 1 x 70 kg	0	70	0	70
+ body weight 220 kg/m	3000	113	677	790
1 TOOLBOX	900	111	39	150
= weights unloaded :		2244	1686	3930
+ carrying capacity	3000	367	2203	2570
= Weights loaded :		2611	3889	6500
:: Gross Vehicle Weight		3100	5500	6500

Optimum BODY MEASUREMENTS with evenload : (x1 = 660 mm)				
Body length	mm	6563	...	4788
overhang	mm	3353	...	1578
overhang %	%	96	...	45
truck length	mm	7978	...	6203
loadpoint	mm	-71	...	816

Rolsteel Enterprises PTY LTD

Custom Body Trucks by
A&D Engineering



Tipplers, Side Tipplers, Flatbeds, Toolboxes, Service Bodies

2/69 Truganina Rd, Malaga
PO Box 2050 Malaga WA 6944
E: singeorzan_aurel@hotmail.com
T: (08) 9249 3286
F: (08) 9249 1431
M: 0421 658 752
Modifiers Code VSB6 M215 WA

Company

Attention

QUOTE NO: DATE

WA HINO

ROB T

2541

28/10/2020

Shire of Wickepin RFQ 6

DESCRIPTION	AMOUNT	GST	AMOUNT INC
#End tipper 3.6 x 2.4 with 450 drop sides framed with 2 mm skin, PTO Pump under body hoist	17,500.00	1,750.00	19,250.00
#Tail gate have release system by air ram operated from cab	1,200.00	120.00	1,320.00
#Tool box behinde the cab 2400 across chassis x 500 mm long x 500 mm high lid tape door hionged on rear side of tool box lid opening 110 thegrees so is open against tipper body	3,100.00	310.00	3,410.00
#UHF Radio	980.00	98.00	1,078.00
#Reverse alarm 32 DB	320.00	32.00	352.00
#Two LED beacon on ski bar	1,550.00	155.00	1,705.00
#Tow bar recce type 50 mm ball	1,080.00	108.00	1,188.00
TOTALO	25,730.00	2,573.00	28,303.00
	24,430		
Note			
#Auto gear box	1,200.00	120.00	1,320.00

Dealer ship fitted the pto switch prior delyvery to body builder

Bengineering

Transport Equipment

Custom Truck Body Specialists

workshop: 8 Piggott dve Australind 6233
 mail: PO Box 295, Mundaring WA 6073
 Ben Harris
 0403 064 676
 ben@bengineering.net.au

A.B.N. 89 123 363 575 A.C.N. 123 363 575

Company	Attention:	Quote
Wa Hino	ROB	Quote#: 00002250 Date: 28/10/2020
		Page: 1

Description	Amount Ex	Code	Amount Inc
Shire of Wickepin 6500kg GVM tipper # tipper body approx 3600mm x 2400mm with 4mm hi tensile floor, 450mm high duragal RHS framed dropsides, 2 way manually locked removable tailgate, tie rails, steps to front corners, full cabshield with mesh window, shovel rack, body prop, underbody hoist with hose burst valve to meet VSB6 requirements and pto, pump etc to suit a manual gearbox.	\$16,700.00	GST	\$18,370.00
# toolbox mounted across chassis behind cab approx 2400mm long x 500mm x 500mm with fully sealed and lockable door to each end hinged on tipper body side	\$3,200.00	GST	\$3,520.00
# 50mm fixed tongue towbar with small round 7 pin plug	\$795.00	GST	\$874.50
# ski bar to cab with 2 x led amber beacons	\$1,495.00	GST	\$1,644.50
# spare wheel fitted to side of chassis	\$350.00	GST	\$385.00
OPTION: reece style towbar \$950+ gst			
NOTE: dealer to fit factory pto switch prior to body fitment			

	GST:	\$2,254.00
Terms: Net 30th after EOM	Total Inc GST:	\$24,794.00
CODE RATE GST SALE AMOUNT	Amount	\$0.00
GST 10% \$2,254.00 \$22,540.00	Balance Due:	\$24,794.00

TRANSPORT EQUIPMENT
CHASSIS MODIFICATIONS
REPAIRS
HYDRAULICS



P & G BODY BUILDERS

PTY LTD A.B.N. 15 061 518 901



3 Cocos Drive
PO Box 1079
Bibra Lake W.A. 6965
Tel: (08) 9434 3499
Fax: (08) 9434 3446

Approved MVIB Repairer No: MRB3214

QUOTE

00013043

WA Hino Sales & Service
PO Box 144
Welshpool WA 6986

Date: 28/10/2020

Quote Contact: Paul Cleggett

Page: Page 1 of 2

Attention: Robert Tot

DESCRIPTION	AMOUNT	TAX
SHIRE OF WICKEPIN		GST
REF NO. RFQ6		GST
Fabricate dropside Tipper Body approximately 3.6mt long x 2400mm wide and 450mm high with the following specifications:		GST
- 100 x 75 Channel mainrunners		GST
- 75 x 40 channel bearers		GST
- 75 x 50 RHS side coaming, incorporating rails and sides, 3 rung pullout step to LH Side		GST
- 3mm, floor to body, fixed step to RH side		GST
- 3mm Cab shield and cab protector to suit crane fitment & operation		GST
- 450mm High dropsides, 35 x 35 x 3 RHS frame to LH side		GST
- 3mm side panels, 2 shovel racks		GST
- Two way operated tailgate, electric actuator operated locking bar		GST
- Shovel rack, side steps, rope rails and rear light guards, mesh covered		GST
- Supply and fit 10 tonne underbody hoist an all necessary hydraulics		GST
- Mounted on sub frame		GST
- Primed and painted required colour including all necessary traffic regulations		GST
COST	\$18,850.00	GST
- Supply and fit 2400 x 500 x 500 toolbox between cabin & body, full width to suit body, lid to open against headboard & fitted with locks weather seal & gas struts	\$1,860.00	GST
- Supply & fit heavy 50m tow hitch to chassis, 7 pin electrical socket & 7pin plug module	\$1,560.00	GST

SUB TOTAL:

GST:

TOTAL:

P&G Body Builders Pty Ltd reserve the right to review
this estimation after a period of thirty (30) days, due to
increasing price costs of raw materials

TRANSPORT EQUIPMENT
CHASSIS MODIFICATIONS
REPAIRS
HYDRAULICS



P & G BODY BUILDERS

PTY LTD A.B.N. 15 061 518 901



3 Cocos Drive
PO Box 1079
Bibra Lake W.A. 6965
Tel: (08) 9434 3499
Fax: (08) 9434 3446

Approved MVIB Repairer No: MRB3214

QUOTE

00013043

WA Hino Sales & Service
PO Box 144
Welshpool WA 6986

Date: 28/10/2020

Quote Contact: Paul Cleggett

Page: Page 2 of 2

Attention: Robert Tot

DESCRIPTION	AMOUNT	TAX
- Supply & fit 2 x LED Amber Beacons to ski bar complete with independent switch	\$1,450.00	GST
- Supply & fit battery isolation switch complete with all required cables	\$740.00	GST
- Supply & fit E stop to RH front of body	\$450.00	GST

SUB TOTAL: \$24,910.00

GST: \$2,491.00

TOTAL: \$27,401.00

P&G Body Builders Pty Ltd reserve the right to review this estimation after a period of thirty (30) days, due to increasing price costs of raw materials



MOTOR VEHICLE REPAIRERS LICENCE # MRB2191



PO BOX 3151
BASSENDEAN W.A 6942
PHONE: (08) 9377 2400
FAX: (08) 9377 2311
A.B.N 936 329 301 28

78 GREY STREET, Bassendean W.A 6053

sales@ombwa.com.au

WHEN QUALITY COUNTS

20th October 2020

Quote GD437

Tender Shire of Wickepin RFQ - 6

Robert Tott

Please find quote as requested for your client

Supply & Delivery of One (1) Truck Tipper GVM 6500 KG

End tip operated form cab of tuck.

Hydraulic Hoist Ram capable to lift 10 ton.

Tool Box fitted between cab and tipper 2400mm L x 500mm W x 500mm H Lid type door hinged on the rear side box lid opening pass 110 degrees so it sits open against tipper body.

Rear tailgate be able to swing and to be able pinned to the side and removable.

In rear tipper mode tailgate is have a release system by air ram operated form cab of tuck.

Tipping body 3600 mm long by 2400 mm wide with drop sides at 450mm in depth and tie rail under the body.

Tray will be 4mm steel to floor and 3mm sides to keep the weight down

The height of tray floor from ground to be 1m.

Tow point 50 mm ball.

Seven pin plug round small .

Master switch electrical disconnect and emergence stop.

12v power output for two-way radios

80ch uhf radio to be fitted with aerial.

Reversing alarm and camera to be fitted.

Flashing beacon LED and to meet work safe standards x 2 to be fitted left and right side of roof of cab .

Cost of build would be \$26,575

Quote will remain valid for 60 days, we thank you for the opportunity to quote.

Thank you for considering a local company keeping local people employed

Gary Dunkerley

Sales

P: 9377 2400

E: sales@ombwa.com.au