

Planning and designing for pedestrians: guidelines



UNCONTROLLED COPY



Department of Transport
Department of Planning
Public Transport Authority



Contents

Foreword	3
Acknowledgements	4
1. Quick Reference Index	5
2. Setting the Scene	18
2.1 Government Roles	19
2.2 Strategic Context	21
3. Standards and Guidelines	27
3.1 Standards and Guidelines Summary	28
3.2 MRWA Standards and Guidelines	31
3.3 Other State Government Standards and Guidelines	34
3.4 Local Government Standards and Guidelines	36
3.5 Austroads Guide to Traffic Management and Guide to Road Design Series	38
3.6 Australian Standards Series	44
3.7 International Good Practice Examples	50
4. Legislation and Regulations	52
4.1 Disability Discrimination Act 1992	53
4.2 Road Traffic Code 2000	54
4.3 Main Roads Act 1930	62
5. Land Use Planning	63
5.1 Land Use Planning	64
6. Pedestrian Characteristics	68
6.1 Pedestrian Characteristics	69
7. Pedestrian Paths	76
7.1 Path Widths	77
7.2 Street Furniture	87
7.3 Grates / Covers	91
7.4 Vertical Clearances	93
7.5 Surfaces	95
7.6 Gradients and Ramps	98

7.7 Steps and Stairs	103
7.8 Crossovers / Driveways	105
7.9 Barricades (including chicanes and bollards)	106
8. Pedestrian Crossing Elements	108
8.1 Kerb Crossing Ramps and Pedestrian Cut-Throughs	109
8.2 Grab Rails	116
8.3 Tactile Ground Surface Indicators (TGSi)	118
8.4 Audio-Tactile Facilities	125
9. Pedestrian Crossing Facilities	129
9.1 Sight Lines	130
9.2 Pedestrian Crossing Warrants	135
9.3 Mid-Block Crossings	140
9.4 Non-Signalised Intersection Crossings	159
9.5 Signalised Intersection Crossings	163
9.6 Roundabouts	172
9.7 Grade Separated Crossings	177
9.8 Railway Crossings	180
10. Pedestrian Guidance Measures	183
10.1 Lighting	184
10.2 Directional, Service and Tourist Signs	188
10.3 Pedestrian Warning Signs	192
11. Speed and Environmental Changes	194
11.1 School Speed Zones	195
11.2 Variable Speed Zones	200
11.3 Shared Zones	202
11.4 Traffic Calming	206
12. Accessible Car Parking Bays	211
12.1 Accessible Car Parking Bays	212
13. Abbreviations	216
14. References	217

Foreword

It is my pleasure to introduce to you the comprehensive 'Planning and Designing for Pedestrians: Guidelines' which outlines good practice for the design and construction of pedestrian facilities in WA.

Pedestrians form the largest single road-user group. In these Guidelines, the word 'pedestrian' includes all non-vehicular mobility (including the use of, for example, wheelchairs, guide dogs or other mobility aids).

Nearly all short trips could be undertaken on foot and even longer trips, whether the main mode of transport is by private car, public transport or cycling - require the road user to be a pedestrian at some stage of the journey. Walking is a key element in the way West Australians travel to work, school and local facilities.

Pedestrians are among the most vulnerable group of road users. In 2010, pedestrians formed 13 per cent of fatalities in the Perth metropolitan region. Not only do they have the least physical protection, pedestrian fatalities comprised disproportionately of the very young and the elderly. While some of these fatalities may be due to a number of factors, pedestrians are unprotected if involved in a crash. It is, therefore, essential to provide facilities that are well designed and appropriate to the particular situation and user group to enhance pedestrian safety throughout the road network system.

Planning and designing good pedestrian infrastructure with well-connected and amenable facilities will benefit the whole community. Creating communities that encourage people to choose walking as a mode of transport is a way to foster more sustainable, healthier and safer communities. Independent travel will be possible for more people including the elderly, children, families and people with disability. Currently one in five people in Australia have a disability. Two out of three people over 75 have a disability and the prevalence of disability will increase further with the ageing of the Australian population. It is estimated that the total number of people who identify themselves as having a disability will increase by about 38 per cent to around 632,600 by 2023.¹

Eventually we hope it will be an enjoyable experience to walk, push your pram or wheel your wheelchair all the way along a route safe in the knowledge that problems with crossing roads, negotiating high kerbs and narrow pavements and finding somewhere easily to have a rest are things of the past.

It is great that these Guidelines are a single source document outlining the policies, planning, guidelines and standards for good pedestrian infrastructure and facilities. It is also pleasing to see that there is great interest across government to ensure that people can travel in a safe environment.

This document is a good example of intersectoral collaboration and has been coordinated by the Department of Transport with funding from Departments of Transport, Planning, Disability Services Commission and the Royal Automobile Club of Western Australia and support from WA Local Government Authority, Public Transport Authority, Main Roads WA and the Institute of Public Works Engineering Australia.



Reece Waldock
Director General of Transport

¹ Disability Services Commission, WA, Count Me In, page 27

Acknowledgements

The 'Planning and Designing for Pedestrians: Guidelines' is a unique collaboration of the Departments of Transport, Planning, Disability Services Commission, Main Roads WA, WA Local Government Association, Public Transport Authority, The Royal Automobile Club of WA and the Institute of Public Works Engineering Australia WA. The Department of Transport commissioned AECOM and Lachlan Millar and Associates to review and revise the 2004 'Infrastructure for Pedestrians' Manual.

Special thanks to the following organisations for funding the project:

- Department of Transport
- Department of Planning
- Disability Services Commission
- The Royal Automobile Club of WA
- Main Roads WA

Project Steering Committee members:

- Alice Haning (Chair) – Department of Transport
- Jillian Woolmer – Department of Transport
- Shanthi Golestani – Department of Planning
- Gary McCarney – Department of Planning
- Caroline Carabott – Main Roads WA
- Jeff Edwards – Disability Services Commission
- Jim Altham - Public Transport Authority
- Nina Hewson – WA Local Government Association
- Marianne Carey - The Royal Automobile Club of WA
- Frank Strever – Institute of Public Works Engineering Australia (IPWEA)

Special acknowledgement to IPWEA and professionals in both state, local and non government organisations that have reviewed and provided feedback on the document.

Photos, graphics and images

A special thanks to all organisations for contributing the photos, graphics and images for the use of this Guideline.

The images in this document are reproduced with permission from SAI Global under licence number 1111-c055.

Disclaimer: This Guideline is an uncontrolled copy and is to be used at the discretion of each individual. The content of this Guideline is correct at the time of release. It is up to each individual to refer back to the relevant resource centres for the current practices.

Any representation, statement, opinion or advice expressed or implied in this publication is made in good faith and on the basis that the government, its employees and agents are not liable for any damage or loss whatsoever which may occur as a result of action taken or not taken (as the case may be) in respect of any representation, statement, opinion or advice referred to herein. Professional advice should be obtained before applying the information contained in this document to particular circumstances.

Published by the Department of Transport

140 William Street, PERTH WA 6000

T: 08 655 16000

www.transport.wa.gov.au

communications@transport.wa.gov.au

First published November 2011 © Western Australia

1. Quick Reference Index

Planning for Pedestrians (Section 5)

Key Design Elements	Important Design Elements	Design Reference
Principles of Pedestrian Network Planning (Section 5.1)	<ul style="list-style-type: none"> • Connected • Comfortable • Convenient • Convivial • Conspicuous 	AGRD Part 6A: Pedestrian and Cyclists Paths, Section 4.1 (AGRD6A/09) AGTM Part 5: Road Management, Tables 3.1 and 3.2 (AGTM05/08)
Pedestrian Accessibility (Section 5.1)	Pedestrian networks should be planned in combination with land uses to provide residential access to mixed use centres and bus routes within a 400m walk, and access to train stations within 800m of strategic and secondary activity centres	Liveable Neighbourhoods (WAPC) Activity Centre Policy (WAPC) Development Control Policy 1.6 Planning to Support Transit Orientated Development (WAPC)
Pedestrian Safety (Section 5.1)	Pedestrian networks should be designed with passive surveillance and good lighting to provide an attractive and safe walking environment	Liveable Neighbourhoods (WAPC) Designing Out Crime Planning Guidelines (WAPC) Reducing Crime and Anti-Social Behaviour in Pedestrian Access Ways Planning Guidelines (WAPC) Procedure for the Closure of Pedestrian Access Ways (WAPC)

Pedestrian Characteristics (Section 6)

Key Design Elements	Important Design Elements	Design Reference
Minimum path widths for different pedestrians (Section 6.1)	Pedestrians in a wheelchair – 1.2m Pedestrian in wheelchair passing pram – 1.5m Two pedestrians in wheelchairs passing – 1.8m	AGRD Part 6A: Pedestrian and Cyclists Paths, Section 4.1.2 and Section 6.2 (AGRD6A/09) AGTM Part 4; Network Management, Section 4.7 (AGTM04/09)

Typical Walking Speeds (Section 6.1)	Fit adult – 1.5m/s Elderly person – 1.0m/s to 1.2m/s Typical speed used in crossing assessments – 1.2m/s	AGTM Part 6: Intersections, Interchanges and Crossings, Section 4.5.3 (AGTM06/07)
--	--	---

Pedestrian Paths (Section 7)

Key Design Elements	Important Design Elements	Design Reference
Footpath Widths (Section 7.1)	<p>Minimum pedestrian through-route width:</p> <ul style="list-style-type: none"> • 1.2m over short distance (allows 1 wheelchair) • 1.8m desirable to allow 2 wheelchairs to pass (1.5m minimum), 2m near schools and small shops • At least 2.4m in commercial or shopping environments • 3m – 4m in busy CBD pedestrian area 	<p>AS1428.1 – 2009 Design for access and mobility Part 1: General Requirements for access – New building works</p> <p>AS1428.2 – 1992 Design for access and mobility Part 2: Enhanced and additional requirements – Buildings and facilities</p> <p>Liveable Neighbourhoods</p> <p>AGRD Part 6A: Pedestrian and Cyclist Paths, Section 6.2.1 (AGRD6A/09)</p> <p>AGTM Part 5: Road Management, Tables 3.1 and 3.2 (AGTM05/08)</p>
Street Furniture (Section 7.2)	<p>The colour of street furniture should contrast with the background</p> <p>Street furniture should be located in the Street Furniture Zone</p>	<p>AGRD Part 6A: Pedestrian and Cyclist Paths (AGRD6A/09)</p> <p>AS 1428.1 – 2009 Design for access and mobility Part 1: General Requirements for access – New building works</p> <p>Public Transport Bus Stop Site Layout Guidelines (PTA)</p>
Grates/ Covers (Section 7.3)	<p>Slots should be sized and aligned to prevent canes, wheels and other mobility aids from falling through</p>	<p>AS 1428.1 – 2009 Design for access and mobility Part 1: General Requirements for access – New building works</p> <p>AGRD Part 6A: Pedestrian and Cyclist Paths (AGRD6A/09)</p>

1. Quick Reference Index

Vertical Clearances (Section 7.4)	Vertical clearance is an absolute minimum of 2m above a footpath (2.5m for shared paths) 2.5m clearance is required under traffic signs over a path	AGRD Part 6A: Pedestrian and Cyclist Paths, Section 6.2.2 (AGRD6A/09) AS 1428.1 – 2009 Design for access and mobility Part 1: General Requirements for access – New building works AS 1742.2 – 2009 Manual of uniform traffic control devices Part 2: Traffic control devices for general use
Surfaces (Section 7.5)	Surfaces must be slip resistant, flat and even	AS 1428.1 – 2009 Design for access and mobility Part 1: General Requirements for access – New building works
Gradient and Ramps (Section 7.6)	Ramp gradient is 1:14 - 1:20. Landing intervals between 9m-15m, dependent on gradient	AS1428.1 – 2009 Design for access and mobility Part 1: General Requirements for access – New building works
Steps and Stairs (Section 7.7)	Treads: 275mm-300mm wide Risers: 150mm-165mm high	AS 1428.1 – 2009 Design for access and mobility Part 1: General Requirements for access – New building works AS 1428.2 – 1992 Design for access and mobility Part 2: Enhanced and additional requirements – Buildings and facilities AS 1428.4.1 – 2009 Design for access and mobility Part 4.1: Means to assist the orientation of people with vision impairment – Tactile ground surface indicators
Crossovers/ Driveways (Section 7.8)	Crossfall < 1:40	AGRD Part 6A: Pedestrian and Cyclist Paths (AGRD6A/09)
Barricades (includes chicanes and bollards) (Section 7.9)	Barricades require special consideration for people with disability and other users	

Pedestrian Crossing Elements (Section 8)

Key Design Elements	Important Design Elements	Design Reference
Kerb Ramp Alignment (Section 8.1)	Ramps on either side of a crossing must be aligned and located perpendicular to the direction of travel	AGRD Part 4: Intersections and Crossings General, Section 8.2.4 (AGRD04/09) AGRD Part 6A: Pedestrians and Cyclists Paths, Table 6.2 (AGRD6A/09)
Kerb Ramp Gradient (Section 8.1)	MRWA maximum gradient is 1:10, absolute maximum is 1:8 (AS1428.1 – 2009) across a maximum length of 1.52m	MRWA Standard Drawing 9831-5649 AS1428.1 – 2009 Design for access and mobility Part 1: General Requirements for access – New building works, Clauses 10.1 and 10.5, Figures 24A, B and C AGRD Part 4: Intersections and Crossings General, Section 8.2.4 (AGRD6A/09)
Kerb Ramp Landings (Section 8.1)	Must be installed at the top and base of ramps with a maximum gradient of 1:40. Preferred minimum width is 1.5m (absolute minimum 1.33m), reduced to 1.2m where wheelchair users are not required to change direction	MRWA Standard Drawing 9831-5649 AS1428.1 – 2009 Design for access and mobility Part 1: General Requirements for access – New building works, Clauses 10.1 and 10.5 AGRD Part 4: Intersections and Crossings General, Section 8.2.4 (AGRD04/09)
Cut-Throughs across Refuges and Traffic Islands (Section 8.2)	Should be used on traffic islands less than 4.5m in depth. The cut-through width should match the crossing width, absolute minimum width of 1.2m, and minimum length of 1.8m	AGRD Part 4: Intersections and Crossings General, Section 8.2.2 (AGRD04/09) AGRD Part 6A: Pedestrian and Cyclists Paths, Section 6.2.1 (AGRD6A/09)
Grab Rails (Section 8.2)	Preferred height is 0.9m Length varies from 0.6m – 1.5m depending on depth of crossing. Grab rails should not be located in medians or ramps <1.2m in depth	MRWA Standard Drawing 9831-5649

Warning TGSI (Section 8.3)	Positioned 0.3m from edge of hazard, perpendicular to the direction of travel and across the entire ramp width Preferred depth of 0.8m (minimum 0.6m)	MRWA Standard Drawing 200931-0089, 200931-0090 and 200931-0091 Public Transport Bus Stop Layout Guidelines (PTA) AS/NZS1428.4.1 – 2009 Design for access and mobility Part 4.1: Means to assist the orientation of people with vision impairment – Tactile ground surface indicators (esp. Appendix C)
Directional TGSI (Section 8.3)	Used where a person has to deviate from their path of travel to access a facility, at a minimum width of 0.8m Also used to guide pedestrian through complicated area, at a minimum width of 0.3m	Public Transport Bus Stop Layout Guidelines (PTA) AS/NZS1428.4.1 – 2009 Design for access and mobility Part 4.1: Means to assist the orientation of people with vision impairment – Tactile ground surface indicators (esp. Appendix C)
Audio - Tactile Facilities (Section 8.4)	Push buttons are to be placed on signal poles within 0.3m of the kerb crossing ramp & TGSI, at a height of 0.9m	MRWA Guideline for Pedestrian Signals (D08#6040)

Pedestrian Crossing Facilities (Section 9)

Key Design Elements	Important Design Elements	Design Reference
Sight Lines (Section 9.1)	All crossing points must provide adequate sight distance for pedestrians and approaching vehicles	AGRDR Part 4A – Signalised and Unsignalised Intersections, Section 3.3 (AGRDR4A/10)

<p>Pedestrian Crossing Warrants (Section 9.2)</p>	<p>MRWA follow a WA warrant system for new or upgraded crossing facilities</p> <p>There are alternative guidelines based on an assessment of pedestrian Level of Service (delay experienced by pedestrians waiting for a safe gap in the traffic), and an example from Queensland that includes a much wider range of assessment criteria</p> <p>Consult with MRWA and / or Local Government Authority before using these alternative guidelines</p>	<p>MRWA Pedestrian Crossing Facilities Guidelines (unpublished)</p> <p>Transport Assessment Guidelines for Developments Volume 3 – Subdivisions (WAPC)</p> <p>Transport Assessment Guidelines Volume 5 – Technical Appendix (WAPC)</p> <p>WA Police Children’s Crossing Warrant - www.police.wa.gov.au</p> <p>Queensland Transport and MRWA Pedestrian Crossing Guideline</p>
<p>Raised and Painted Medians (Section 9.3)</p>	<p>Minimum desirable median width of 1.8m (1.5m minimum if pedestrian facilities are included) to provide protection to cyclists, person pushing pram, person in wheelchair</p> <p>Pedestrian cut-throughs or refuges should be provided at regular intervals for wheeled pedestrians, with a desirable cut-through width of 2.5m</p>	<p>MRWA Standard Drawings 200331-139, 200331-140</p> <p>AGRD Part 4: Intersections and Crossings – General, Section 8.2.2 (AGRD04/09)</p>
<p>Refuges (Section 9.3)</p>	<p>Require a minimum depth of 1.8m (1.5m minimum) to provide protection to cyclists, person pushing pram, person in wheelchair</p> <p>The desirable cut-through width is 2.5m (absolute minimum width of 1.2m), other than signalised intersections where pedestrians are not required to wait within the island / cut-through.</p> <p>Parking restrictions and lighting must be provided to meet visibility requirements</p> <p>Grab rails can be installed in refuges $\geq 2\text{m}$</p> <p>Pedestrian warning signs should be installed on roads with speed limits $\geq 70\text{km/h}$</p>	<p>MRWA Standard Drawings 200331-139, 200331-140</p> <p>AGRD Part 4: Intersections and Crossings – General, Section 8.2.2 and Commentaries 5 – 6 (AGRD04/09)</p> <p>AS 1742.10 – 2009 Manual of uniform traffic control devices Part 10: Pedestrian control and protection, Clause 9.2</p>

<p>Kerb Extensions (Section 9.3)</p>	<p>The depth of kerb extensions should extend to the edge of parking lanes</p> <p>Kerb extensions should narrow the road to 10 m where there are on-road cycle lanes, narrower on other routes to match the desired speed environment</p>	<p>AGRD Part 4: Intersections and Crossings – General, Section 8.2.2 and Commentary 6 (AGRD04/09)</p>
<p>Zebra Crossings (Section 9.3)</p>	<p>In addition to warrant requirements, zebra crossings can only be installed on roads with:</p> <ul style="list-style-type: none"> • No more than 1 lane of traffic in each direction • Adequate sight distance • A maximum posted speed of 50km/h (excluding slip lanes), maximum 85%ile speed of 60km/h (except at slip lanes) 	<p>MRWA Standard Drawings 200331-164</p> <p>AGRD Part 4: Intersections and Crossings – General, Section 8.2.3 and Commentaries 7- 8 (AGRD04/09)</p> <p>AS 1742.10 – 2009 Manual of uniform traffic control devices Part 10: Pedestrian control and protection, Clause 6</p>
<p>Wombat Crossings (Section 9.3)</p>	<p>Installed in combination with zebra crossings in low speed environments</p> <p>Platform height is 100mm, or a maximum of 75mm on bus routes</p> <p>Platform approach ramps are a minimum of 1.2m, with a maximum gradient of 1:20 on bus and cycle routes</p> <p>Platform surface must provide adequate contrast with crossing markings, such as black or red asphalt</p>	<p>MRWA Standard Drawings 200631-0001</p> <p>AGTM Part 8: Local Area Traffic Management, Section 7.2.4 (AGTM08/08)</p> <p>AS 1742.10 – 2009 Manual of uniform traffic control devices Part 10: Pedestrian control and protection, Clause 6</p>
<p>Pelican and Puffin Signalised Crossings (Section 9.3)</p>	<p>Suitable for locations with high pedestrian and traffic volumes which meet MRWA warrants or alternative crossing guidelines. Suitable for roads with speeds ≤70km/h</p> <p>Signalised crossings can be the most appropriate treatment for sites with large volumes of pedestrian with disability or sites unsuitable for zebra crossings</p>	<p>MRWA Standard Drawings 200431-0116</p> <p>AGRD Part 4: Intersections and Crossings – General, Section 8.2.3 (AGD04/09)</p> <p>AS 1742.10 – 2009 Manual of uniform traffic control devices Part 10: Pedestrian control and protection, Clause 8</p> <p>AS1742.14 – 1996 Manual of uniform traffic control devices Part 14: Traffic signals</p>

<p>Warden Controlled Children's Crossings (Section 9.3)</p>	<p>A School Principal or a recognised school/parent organisation must apply to , the Student Pedestrian Policy Unit (SPPU) at WA Police for a Children's Crossing</p> <p>The assessment is based on the number of children and vehicles passing a crossing point before and after school</p> <p>Type 'A' crossings are managed by a trained crossing guard appointed by the Police. Type 'B' crossings are managed by a trained crossing guard by the school.</p>	<p>WA Police Children's Crossing Warrant - www.police.wa.gov.au</p> <p>MRWA Standard Drawings 9120-174 and 9531-2169</p> <p>AS 1742.10 – 2009 Manual of uniform traffic control devices Part 10: Pedestrian control and protection, Clause 7</p>
<p>Non-Signalised Intersections (Section 9.4)</p>	<p>Design details such as kerb radii and provision of refuges or kerb extensions can greatly influence pedestrian safety at unsignalised intersections</p> <p>Recommended kerb radii are 6m for local access streets and 9m for intersections with neighbourhood connectors</p>	<p>Liveable Neighbourhoods (WAPC)</p> <p>AGRDR Part 4: Intersections and Crossings – General, Section 5 (AGRDR04/09)</p> <p>AGRDR Part 4A: Signalised and Unsignalised Intersections, Section 8.3 (AGRDR4A/10)</p>
<p>Signalised Intersection Crossings (Section 9.5)</p>	<p>Pedestrian crossing facilities should be provided at all signalised intersections as per MRWA guidelines, either:</p> <ul style="list-style-type: none"> • Parallel pedestrian phases with partial protection (minimum of 3 seconds) • parallel pedestrian phases with full Protection • Exclusive pedestrian phases (allows for diagonal crossings) <p>Zebra crossings at slip lanes should be provided as per the MRWA warrant.</p>	<p>MRWA Guideline for Pedestrian Signals ((D08#6040)</p> <p>MRWA Standard Drawing 200531-0038 (slip lane crossings)</p> <p>AGRDR Part 4A: Signalised and Unsignalised Intersections (AGRDR4A/10)</p> <p>AS1742.14 – 1996 Manual of uniform traffic control devices Part 14: Traffic signals</p>

<p>Roundabouts (Section 9.6)</p>	<p>Roundabouts should be designed with adequate entry curvature or deflection to reduce the speed of approaching vehicles</p> <p>Recommended to locate kerb ramps and median cut-throughs at least 6m from the vehicle holding line (1 - 2 car lengths)</p> <p>Where pedestrian volumes are high and there is speed environment $\leq 40\text{km/h}$, zebra crossings can be considered</p> <p>In some cases, signalised intersections may be more appropriate where pedestrian and traffic volumes are high, or there is a large proportion of children, elderly or pedestrians with disability</p>	<p>MRWA Standard Drawings 200331-197, 200331-201 and 200331-202</p> <p>AGTM Part 6: Intersections, Interchanges and Crossings, Section 4 (AGTM06/07)</p> <p>AGRD Part 4B: Roundabouts, Section 5.2 (AGRD4B/11)</p>
<p>Grade Separated Crossings (Section 9.7)</p>	<p>Generally only provided along arterial roads with high traffic volumes and traffic speeds.</p> <p>To encourage pedestrian patronage across grade separated facilities:</p> <ul style="list-style-type: none"> • Overpasses should be constructed with a maximum change in level of 6.5m • Underpasses should allow visibility along the length of the underpass and be constructed with a maximum change in level of 3.5m 	<p>AGTM Part 6: Intersections, Interchanges and Crossings, Table 8.1 (AGTM06/07)</p> <p>AGRD Part 4C; Interchanges, Section 4.4 (AGRD4C/09)</p> <p>AS5100.1 – 2004 Bridge design Part 1: Scope and general principles, Clause 9.1 and Clause 12</p> <p>Designing Out Crime Planning Guidelines (WAPC)</p>
<p>Railway Crossings (Section 9.8)</p>	<p>At grade railway crossings can be:</p> <ul style="list-style-type: none"> • Uncontrolled pedestrian mazes at non-electric railway crossings (at sites with adequate sight lines) • Automatic lockable gates at electric railway crossings 	<p>AS1742.7 – 2007 Manual of uniform traffic control devices Part 7: Railway crossings, Clause 6 and Appendix F</p> <p>AGTM Part 6: Intersections, Interchanges and Crossings, Table 8.1 (AGTM06/07)</p> <p>AGRD Part 4: Intersections and Crossings – General, Section 10.6 (AGRD04/09)</p>

Pedestrian Guidance Measures (Section 10)

Key Design Elements	Important Design Elements	Design Reference
Lighting along Roadways Section 10.1)	<p>Local roads require minimum pedestrian lighting level of P3/P4/P5</p> <p>Collector roads require minimum pedestrian lighting level of P3/P4</p> <p>Arterial roads are to be designed to a minimum vehicular lighting level of V3</p>	<p>MRWA Lighting Design Guideline for Roadway and Public Spaces (D09#291515)</p> <p>AS/NZS1158.1.1 – 2005 Lighting for roads and public spaces Part 1.1: Vehicular traffic (Category V) lighting – Performance and design requirements, Figure 2.1</p> <p>AS/NZS1158.3.1 – 2005 Lighting for roads and public spaces Part 3.1: Pedestrian area (Category P) lighting – Performance and design requirements, Figure 2.1</p>
Lighting level for Pedestrian and Cyclists Pathways (Section 10.1)	<p>Pathways are to be lit to a minimum horizontal and vertical illuminance of 5 lux, with a minimum of 20 lux at sites with high pedestrian volumes or conflict</p>	<p>MRWA Lighting Design Guideline for Roadway and Public Spaces (D09#291515)</p> <p>AS/NZS1158.3.1 – 2005 Lighting for roads and public spaces Part 3.1: Pedestrian area (Category P) lighting – Performance and design requirements</p>
Lighting Pole Design for Pedestrian and Cyclists Pathways (Section 10.1)	<p>Poles should be setback from path by 0.8m – 1m (0.5m absolute minimum for cyclist paths)</p> <p>Pedestrian lights to be mounted at a height of 7m, with the outreach arm length between 0 to 1.5m</p>	<p>MRWA Lighting Design Guideline for Roadway and Public Spaces (D09#291515)</p> <p>MRWA Standard Drawing 0448-3007 and 0448-3008</p>
Lighting level for Pedestrian Crossings (Section 10.1)	<p>Minimum horizontal illuminance on a marked pedestrian crossing is 30 lux, except for sites with low pedestrian and traffic volumes where it may be reduced to 20 lux</p>	<p>AS/NZS1158.4 – 2009 Lighting for roads and public spaces Part 4: Lighting of pedestrian crossings</p>
Lighting for Pedestrian Tunnels and Underpasses (Section 10.1)	<p>Category P10 lighting is to be provided, with a minimum point horizontal and vertical illuminance of 17.5 lux</p> <p>For tunnels longer than 20 metres, lighting is to be provided both day and night</p>	<p>AS/NZS1158.3.1 – 2009 Lighting for roads and public spaces Part 3.1: Pedestrian area (Category P) lighting – Performance and design requirements</p>

Light pole placement along footpaths (Section 10.1)	Light poles (and other street furniture) should be placed outside the pedestrian through-route zone (desirable minimum width of 1.5m , absolute minimum width of 1.2m)	See Section 7.2
Pedestrian and Guidance signs (Section 10.2)	Ideal sign heights are between 1.4m to 1.6m, absolute minimum height is 1m Where there are likely to be large crowds, minimum sign height is 2m Desirable sign height above pathways is 2.5m	AS1428.2 – 1992 Design for access and mobility Part 2: Enhanced and additional requirements – Buildings and facilities, Clause 17 AS1428.1 – 2009 Design for access and mobility Part 1: General Requirements for access – New building works, Clause 8
Pedestrian Warning Signs (Section 10.3)	The appropriate placement of pedestrian warning signs is included in MRWA standard drawings for pedestrian facilities, and outlined in AS 1742.10 – 2009	MRWA Standard Drawings 200431-0116, 200331-164, 200331-139, 200331-140, 9120-174 and 9531-2169 AS1742.10 – 2009 Manual of uniform traffic control devices Part 10: Pedestrian control and protection, Clause 11

Speed and Environmental Changes (Section 11)

Key Design Elements	Important Design Elements	Design Reference
School Zone Speed Limits (Section 11.1)	40km/h for schools on roads with speed limits of 50, 60 and 70km/h 60km/h for roads with speed limits of 80 and 90km/h	MRWA Speed Zone Application and Technical Guidelines (D10#87689 and D10#92683) AS1742.4 – 2008 2009 Manual of uniform traffic control devices Part 4: Speed controls
School Zone Time Schedule (Section 11.1)	Three time schedules for different zones within WA: <ul style="list-style-type: none"> • Northern region: 7.30-9.00am, 2.00-3.00pm • Carnarvon region: 7.30-9.00am, 2.00-4.00pm • Metropolitan and all other areas: 7.30-9.00am, 2.30-4.00pm 	MRWA Speed Zone Application and Technical Guidelines (D10#87689 and D10#92683)

<p>School Zone Length (Section 11.1)</p>	<p>The minimum lengths for school zones are:</p> <ul style="list-style-type: none"> • 200 metres – where the school zone speed limit is 40km/h • 300 metres – where the school zone speed limit is 60km/h 	<p>MRWA Speed Zone Application and Technical Guidelines (D10#87689 and D10#92683)</p>
<p>Shared Zones (Section 11.3)</p>	<p>Shared zones can generally be applied where:</p> <ul style="list-style-type: none"> • Traffic volumes are < 300 vehicles per day after the shared zone is installed • It is desired for pedestrian movements to take priority over vehicular movements • Shared zone signs with a speed limit of 10km/h are installed at the start and end of the zone 	<p>MRWA Speed Zone Application and Technical Guidelines (D10#87689 and D10#92683)</p> <p>AGTM Part 7 – Traffic Management for Activity Centres (AGTM07/09)</p> <p>AGTM Part 8 – Local Area Traffic Management, Section 7.5.7 (AGTM08/08)</p> <p>AS1742.4 – 2008 Manual of uniform traffic control devices Part 4: Speed controls</p>
<p>Traffic Calming (Section 11.4)</p>	<p>Traffic calming can be applied to local roads and on roads through busy activity centres where there are large pedestrian volumes</p> <p>Traffic calming is generally self-enforcing, using physical measures and environmental changes to provide clear cues for motorists to slow down</p>	<p>MRWA Guideline for Local Area Traffic Management (D08#102211)</p> <p>AGTM Part 7 – Traffic Management for Activity Centres (AGTM07/09)</p> <p>AGTM Part 8 – Local Area Traffic Management (AGTM08/08)</p>

Accessible Car Parking Bays (Section 12)

Key Design Elements	Important Design Elements	Design Reference
<p>Angled parking space dimension (Section 12.1)</p>	<p>Parking space to be minimum of 2.4m wide by 5.4m long</p> <p>Additional shared space a minimum of 2.4m wide by 5.4m long on one side of the parking space</p> <p>A clear area of 2.4m wide by 2.4m long at the front or rear of the parking space</p>	<p>AS/NZS2890.6 – 2009 Parking facilities Part 6: Off-street parking for people with disabilities</p>
<p>Parallel parking space dimension (Section 12.1)</p>	<p>Parking space to be minimum of 3.2m wide by 7.8m long</p> <p>An additional shared space of 1.6m wide by 7.8m long on one side of the parking space</p>	<p>AS/NZS2890.6 – 2009 Parking facilities Part 6: Off-street parking for people with disabilities</p>
<p>Headroom (Section 12.1)</p>	<p>Minimum headroom of 2.5m above parking spaces</p> <p>Minimum headroom of 2.2m above vehicular travel path from entrance/exit to the car parking spaces</p>	<p>AS/NZS2890.6 – 2009 Parking facilities Part 6: Off-street parking for people with disabilities</p>
<p>Pavement markings and signage (Section 12.1)</p>	<p>All accessible parking spaces are to be delineated by the blue and white universal access symbol painted in the parking space</p> <p>Signs should be used where the space is reserved for ACROD permit holders only</p>	<p>AS/NZS2890.6 – 2009 Parking facilities Part 6: Off-street parking for people with disabilities</p>
<p>Accessible Parking Supply (Section 12.1)</p>	<p>As set out in the Building Code of Australia for different land uses</p>	<p>BCA, Table D3.5</p>

2. Setting the Scene

In this Section

2.1 Government Roles

2.1.1 State Government Roles

2.1.2 Local Government Roles

2.2 Strategic Context

2.2.1 International Charter for Walking

2.2.2 National Disability Strategy 2010 - 2020

2.2.3 Healthy Spaces and Places

2.2.4 Walk WA: A Walking Strategy for Western Australia 2007 - 2020

2.2.5 Towards Zero (2008-2020)

2.2.6 RoadWise Program (since 1994)

2.2.7 Directions 2031 and Beyond (2010)

2.2.8 Activity Centres for Perth and Peel Policy

2.2.9 Count Me In – Disability Future Directions (2009)

2.2.10 Liveable Neighbourhoods (2007; updated 2009)

2.1 Government Roles

Objective

To describe the roles of different government agencies involved in developing and promoting a walkable environment.

Key Points

State and Local Government have a range of interlinked roles and responsibilities.

Government organisations work together to raise the profile of walking and encourage walking at a strategic level as a healthy and sustainable transport mode.

2.1.1 State Government Roles

Department of Transport

The Department of Transport recognises that walking is a legitimate mode of transport to replace short car trips. The Department's purpose is to 'provide a safe, accessible, sustainable and efficient transport services, which promote economic prosperity and enhance the lifestyles of all.' The Department was a joint partner of the *Walk WA: A Walking Strategy for Western Australia 2007 – 2020* which sets out the vision that 'By 2020, Western Australia will be a vibrant, safe, accessible place with a supportive walking environment where all West Australians enjoy walking for transport, health and recreation'.

www.transport.com.au

Department of Planning

Provides the strategic direction for planning policy and urban and regional development in Western Australia. Planning strategies and regulations influence the walkability of new developments. An example is Transit Orientated Development which seeks to concentrate activities within a walkable catchment area, encouraging people to walk within a centre to access a range of daily activities. Planning guidelines also influence the safety and attractiveness of streets, increasing interaction between buildings and adjacent paths to reduce crime and improve personal safety.

www.planning.wa.gov.au

Disability Services Commission

Is the State Government agency responsible for advancing opportunities, community participation and quality of life for people with disability through services and funding. As well as directly assisting people with disability, the Commission facilitates improved community access through education, information, publications and support. This includes guidance on planning for better access, from consultation and universal design to legislative requirements.

www.disability.wa.gov.au

Physical Activity Taskforce (Be Active WA)

Promoted under the *Be Active WA* banner, the Taskforce links programs and initiatives conducted by a range of government and community agencies. The Taskforce was formed in 2001 in response to the long-term decline of Western Australia physical activity levels. One of the major focus areas is the Walk WA strategy, developed in conjunction with State and Local Government. Walk WA provides a coordinated action plan to support more walking in our communities, leading to health, transport and environmental outcomes.

www.beactive.wa.gov.au

Main Roads Western Australia (MRWA)

Is responsible for managing the state road network, which includes highways and freeways within Western Australia as well as ensuring safe and efficient road access for all road users including pedestrians. Main Roads responsibility includes the development of standard guidelines and detailed standard drawings for state and local road infrastructure.

Main Roads are the approving body for ensuring consistent application of signs and pavement markings on all roads in Western Australia. For this reason, Main Roads are involved in the design and approval process of pedestrian facilities on state and local road networks.

www.mainroads.wa.gov.au

Public Transport Authority (PTA)

Is responsible for Transperth and school bus services, regional coach services and maintenance and delivery of passenger and freight rail networks. Walking forms part of every public transport trip, highlighting the importance of planning accessible walking links to and from bus stops and train stations. As well, bus stop infrastructure is often located within footpath areas, requiring consideration of other footpath users as well as passenger access. PTA often coordinates the delivery of new bus or station infrastructure with Local Government and / or MRWA. PTA has developed guidelines on the design of bus stop infrastructure to provide a consistent approach across Western Australia, and have a long-term Bus Stop Accessibility Works Program. PTA is also responsible for providing safe pedestrian access across rail corridors, and assists with the development of shared path networks along these corridors.

www.pta.wa.gov.au

2.1.2 Local Government Roles

WA Local Government Association

The WA Local Government Association (WALGA) lobbies and negotiates on behalf of the 140 Local Governments in WA. As the peak lobbying and advocacy organisation, it has a strong influence on how policy decisions are made that affect the sector. Senior WALGA staff regularly consult with Ministers, politicians and senior bureaucrats and negotiate supplier agreements with senior executives of organisations with the capacity to deliver state-wide services.

www.walga.asn.au

Local Government

Councils are responsible for planning, constructing and maintaining much of the pedestrian network, specifically responsible for facilities on local distributor and access roads, and through many parks and reserves.

Councils are also responsible for approving the design of many new residential developments, and regeneration projects for town centres and recreational areas. The design and connectivity of these areas play a major role in the overall walkability of a neighbourhood.

Councils also implement TravelSmart projects promoting walking opportunities. This includes establishing walking groups, developing local walking plans and installing wayfinding signage. TravelSmart Officers work with schools to improve the safety and attractiveness of walk to school routes.

Check local government websites for Council policies, projects and technical specifications in each city or shire region.

Links to Local Government websites are available on the following page:

www.walga.asn.au/about_lg/council_websites

2.2 Strategic Context

Objective

To describe the key policies and strategies at the International, National, State and Local Government level.

Key Points

Walking is promoted as a healthy and sustainable transport mode at all levels of government.

2.2.1 International Charter for Walking

The International Charter for Walking was developed through the WALK21 international conference series in Melbourne, 2006. The Charter provides a common framework to help communities across the world refocus their existing policies, activities and relationships to create a culture where people choose to walk. Local, State and National Government organisations are encouraged to commit to the Charter, alongside individual community members.

The Charter focuses on the following strategic principles:

- Increased inclusive mobility
- Well designed and managed spaces and places for people
- Improved integration of networks
- Supportive land-use and spatial planning
- Reduced road danger
- Less crime and fear of crime
- More supportive authorities
- A culture of walking

The Charter includes a practical list of actions that can be made in most communities, with authorities encouraged to add actions in response to specific local needs. A copy of the Charter can be found on the Walk 21 website www.walk21.com/charter



2.2.2 National Disability Strategy 2010 - 2020

The National Disability Strategy sets out a ten year national plan for improving life for Australians with disability, their families and carers. The Strategy has an important role in protecting, promoting and fulfilling the human rights of people with disability.

The Strategy seeks to create a more cohesive approach across Australia whilst recognising the specific roles and responsibilities assigned to each level of government and the community. The Strategy focuses on six outcome areas, including policies and actions;

- Inclusive and accessible communities
- Rights protection, justice and legislation
- Economic security
- Personal and community support
- Learning and skills
- Health and wellbeing

Implementing the safe and accessible design of pedestrian infrastructure recommended in this Guideline can assist with achieving many of these objectives, particularly creating a more inclusive community.

A key strategy initiative is the introduction of a periodic report using trend data to track national progress for people with disability in Australia. The report will be prepared every two years and will provide data for the six outcome areas of the Strategy. A copy of the Strategy is available from: www.coag.gov.au



2.2.3 Healthy Spaces and Places

Healthy Spaces and Places is a national guide for planning, designing and creating sustainable communities that encourage healthy living. It promotes the ongoing development and improvement of built environments where it is easier for Australians to be active by walking, cycling and using public transport every day.

www.healthyplaces.org.au/site

Healthy Active By Design is a Western Australian project that builds on the Healthy By Design resources developed by Victoria and Tasmania. The resource was at the end of Phase 1 development in 2011.

www.beactive.wa.gov.au/index.php?id=263



2.2.4 Walk WA: A Walking Strategy for Western Australia 2007 - 2020

The Walk WA Strategy recognises the health, transport and environmental benefits of supporting more people to walk, more often throughout WA. People walk regularly for both recreation and transport, with walking being the most popular physical activity for adults in Western Australia.

People most commonly walk on local streets and paths, and the Strategy aims to improve these environments to enable more people to walk. The Strategy includes a detailed action plan for local and state government stakeholders, with short term targets to:

- Increase the proportion of adults who report walking;
- Increase the number of walking trips per adult per week.
- Increase the proportion of school-aged children who walk to and from school.

Improving existing or constructing new pedestrian facilities will play an important role in achieving the Walk WA objectives and targets.

www.beactive.wa.gov.au/index.php?id=350



2.2.5 Towards Zero (2008-2020)

Towards Zero is Western Australia's road safety strategy for 2008-2020. The target is to see a reduction of 11,000 people killed or seriously injured on WA roads between 2008 and 2020.

The strategy outlines four cornerstones for a safe road system regarding road user behaviour, road infrastructure, speeds and vehicles. Of particular importance to pedestrian safety is the safe speeds cornerstone. The objective to prevent death and serious injury is ultimately to ensure impact speeds are within human tolerance, which is less than 30 km/h for a pedestrian and car conflict.

Towards Zero outlines five guiding principles to achieve a safe system:

- The limits of human performance – acknowledging that humans make mistakes and that fallibility is essential.
- The limits of human tolerance to violent forces – seeking to keep forces in collisions within our physical limits.
- Shared responsibility – taking an individual and shared role in road safety.
- A forgiving road system – aiming for an 'inherently safe' road system designed such that when crashes do occur, deaths and serious injuries can be avoided.
- Increased use of public transport – reducing the number of vehicles on the road.

www.ors.wa.gov.au/Towards-Zero.aspx



2.2.6 RoadWise Program (since 1994)

The RoadWise Program is the WALGA's Community Road Safety Program and has been in operation since 1994. The aim of RoadWise is to facilitate the involvement of Local Government and the community (through the community road safety network) in adopting and applying the safe system approach and specific initiatives of the *Towards Zero* strategy.

The Program consists of a community road safety network, supported by regional road safety officers who work with Local Government, RoadWise Committees, road safety partner agencies and the Community Road Safety Grants Program.

The RoadWise Program is supported by the Road Safety Council of WA and funded through the Road Trauma Trust Fund; which is one third of speed and red light camera infringements received in WA. The RoadWise Program is applied throughout the state with a Road Safety Officer based in each region.

www.walga.asn.au

www.roadwise.asn.au/

The Road Safety Around School Guidelines are particularly useful:

www.roadwise.asn.au/resources



2.2.7 Directions 2031 and Beyond (2010)

Directions 2031 is a strategic plan for the future growth of the metropolitan Perth and Peel region. It provides a framework to guide the detailed planning and delivery of housing, infrastructure and services necessary to accommodate a population growth of between 35 and 40 percent between 2010 and 2031.

Directions 2031 identifies a connected city model as the preferred medium-density future growth scenario. This includes the following growth characteristics:

- Reducing energy dependency and greenhouse gas emissions.
- Planning and developing key public transport corridors, urban corridors and transit oriented developments to accommodate increased housing needs and encourage reduced vehicle use.
- Creating and enhancing transport and freight movement networks between activity centres and Industrial centres.

www.planning.wa.gov.au/publications/826.asp



2.2.8 Activity Centres for Perth and Peel Policy

The main purpose of Activity Centre policy is to specify broad planning requirements for the planning and development of new activity centres and the redevelopment and renewal of existing centres in Perth and Peel. The policy outlines the hierarchy of centres for Perth and Peel, and identifies requirements such as walkable catchments, public transport access and residential catchments for the different centre categories.

The Activity Centre policy and Directions 2031 provide a consistent planned network of activity centres, aiming to evenly distribute jobs, services and amenities throughout Perth and Peel.

The policy also reflects the Western Australian Planning Commission's (WAPC) intention to encourage and consolidate residential and commercial development in mixed-use activity centres so that they contribute to a balanced network.

www.planning.wa.gov.au/publications/1178.asp



2.2.9 Count Me In – Disability Future Directions (2009)

The Disability Future Directions strategy identifies 13 priorities to facilitate change in transport, housing, community attitudes, education, employment and technology over the next 15 to 20 years in Western Australia. The strategy seeks to develop a good future for people with disability, families and carers, and to benefit many other West Australians, such as elderly people.

One of the strategy priorities is 'well-planned and accessible communities'. A key recommendation is for greater consultation with people with disability, family and carers in the planning and development of projects. Increased innovation in the development of accessible communities and universal housing design is another key focus.

www.disability.wa.gov.au/cmistrat.html

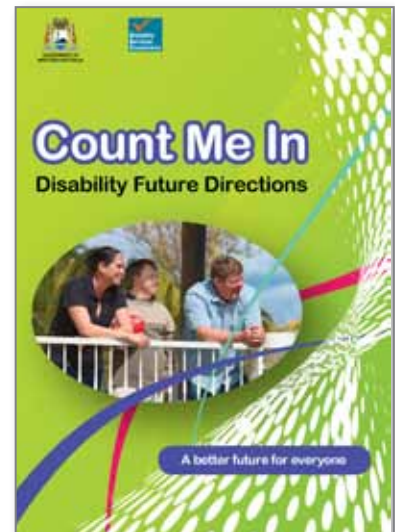

2.2.10 Liveable Neighbourhoods (2007; updated 2009)

Liveable Neighbourhoods was adopted by the WA Planning Commission as an alternative to previous subdivision policies. It proposes to achieve compact, better defined and more sustainable urban communities.

Among the principle aims of the policy document are:

- To provide for an urban structure of walkable neighbourhoods clustering to form towns of compatible mixed uses in order to reduce car dependence for access to employment, retail and community facilities
- To ensure access to services and facilities are designed for all users, including users with disabilities
- To provide for access generally by way of an interconnected network of streets which facilitate safe, efficient and pleasant walking, cycling and driving.

www.planning.wa.gov.au/publications/919.asp



3. Standards and Guidelines

In this Section

- 3.1 Standards and Guidelines Summary
 - 3.1.1 Standards and Guidelines for State Government Controlled Roads
 - 3.1.2 Standards and Guidelines for Local Roads
 - 3.1.3 Non-Standard Design
- 3.2 MRWA Standards and Guidelines
 - 3.2.1 MRWA Online Reference Material
 - 3.2.2 Relevant MRWA Policies and Guidelines
 - 3.2.3 Relevant MRWA Standard Drawings
- 3.3 Other State Government Standards and Guidelines
 - 3.3.1 Liveable Neighbourhoods (2007; updated 2009)
 - 3.3.2 Transport Assessment Guidelines for Developments
 - 3.3.3 Public Transport Bus Stop Layout Guidelines
- 3.4 Local Government Standards and Guidelines
 - 3.4.1 Local Government
 - 3.4.2 Road Safety Around Schools Guidelines
 - 3.4.3 Walkability Audit Tool
- 3.5 Austroads Guide to Traffic Management and Guide to Road Design Series
 - 3.5.1 Austroads Guide to Traffic Management Series
 - 3.5.2 Austroads Guide to Road Design Series
- 3.6 Australian Standards
 - 3.6.1 AS/NZS1158 – Lighting for Roads and Public Spaces Series
 - 3.6.2 AS1428 – Design for Access and Mobility Series
 - 3.6.3 AS1742 Manual of Uniform Traffic Control Devices Series
 - 3.6.4 AS2353 Pedestrian Push-Button Assemblies
 - 3.6.5 AS2890 Parking Facilities Series
 - 3.6.6 AS5100 Bridge Design Series
- 3.7 International Good Practice Examples
 - 3.7.1 Manual for Streets, UK
 - 3.7.2 Context Sensitive Solutions (CSS), Institute of Transportation Engineers 2010

3.1 Standards and Guidelines Summary

Objective

To describe the range of standards and guidelines which are relevant for pedestrian infrastructure.

Key Points

There is a range of reference material which can be applicable for pedestrian facilities.

3.1.1 Standards and Guidelines for State Government Controlled Roads

MRWA has developed policies, guidelines and specifications that are applicable to MRWA works, generally taking place on highways and state roads.

For MRWA sites, MRWA reference material takes precedence over Austroads or Australian Standards material. Regulatory signs and markings on all roads must meet MRWA or Australian Standards. Where specific details cannot be sourced through the MRWA standards and guidelines, Australian Standards and / or Austroads should be referenced.

If there is an applicable reference document produced by another Western Australian State Government department, such as the PTA Public Transport Bus Stop Site Layout Guidelines, this would take precedence over Austroads and Australian Standards.

Hierarchy for State Government Controlled Roads

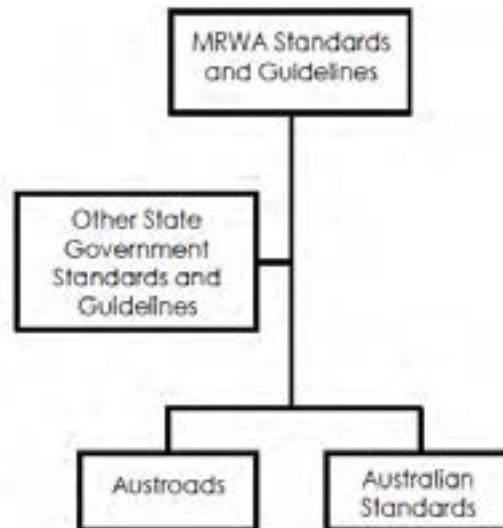

3.1.2 Standards and Guidelines for Local Roads

For local roads, Local Government standards and guidelines take precedence. The only exception is traffic signals, regulatory signs and pavement markings for which MRWA has jurisdiction for all roads throughout Western Australia.

Local roads often have reduced traffic volumes and speeds compared to state roads, and can prioritise multi-modal local access over efficient traffic flows. For this reason, for other components of a local road design, other State Government or Australian reference material may be more applicable than MRWA reference material.

For example, guidelines in Liveable Neighbourhoods provide more appropriate design information for local road environments. For busy Activity Centres, Austroads may provide the most applicable design guidance. International guidelines such as the UK Manual for Streets may also assist with the design of low speed, low volume streets.

MRWA standards are applicable for the design of traffic signals, regulatory signs and pavement markings. MRWA must approve the installation of these devices. If there is a discrepancy between a preferred design and MRWA standards, the reference material and reasoning for the alternative design must be documented for consideration by MRWA.

Hierarchy for Local Roads

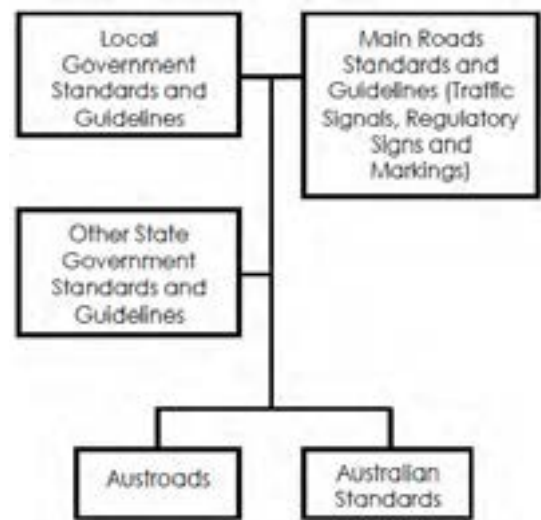

3.1.3 Non-Standard Design

Often there are site specific constraints which require a non-standard design approach based on an individual's judgement. A road safety audit can assist with the design process. Consultation with affected users (such as representatives of disability groups, utility companies, pedestrian and cycling advocates as appropriate) can also greatly assist with identifying the most appropriate solution.

In these cases, pedestrian infrastructure must always comply with the Road Traffic Code 2000 regulations, and the process and justification for the non-standard design should be documented.

Reference material from other regions in Australia (such as Queensland Transport and Main Roads, RTA, VicRoads, or Local Government areas in other states) or international reference material can be useful if there is no relevant design information in West Australian or Australian standards.

The Western Australian Office of Road Safety and MRWA have adopted the Towards Zero strategy, which advocates for a Safe System approach to road design. A Safe System approach recognises that it is not possible to prevent all crashes, but the road environment should be designed to reduce the severity of crashes, aiming to reduce death and serious injury. The Safe System principles should be considered in all design. More information is available on the Office of Road Safety website:

www.ors.wa.gov.au/Towards-Zero.aspx



Albany Highway, Gosnells

3.2 MRWA Standards and Guidelines

Objective

To outline MRWA standards and guidelines which are relevant for pedestrian infrastructure.

Key Points

MRWA have an extensive online library of policies, guidelines and standards.

3.2.1 MRWA Online Reference Material

MRWA standards, guidelines and other technical information are available on the MRWA website – www.mainroads.wa.gov.au

From the MRWA home page, following the links to:

- Building Roads (tab at top of home page)
- Technical & Standards (in the list on left hand side of web page)

There is an extensive range of reference material available in this section. Follow the links through to the relevant reference area. For the design of pedestrian infrastructure, relevant information will generally be in the 'Road and Traffic Engineering' section, with specific pedestrian information in the 'Geometric Design' and 'Traffic Management' subsections.

To search through a list of available documents within each subsection, use the keyword search function at the top of the web page.



3.2.2 Relevant MRWA Policies and Guidelines

A number of MRWA policies and guidelines are referenced in this Manual. A list of these guidelines is provided below. These documents can be found on the MRWA website (unless otherwise noted).

- Draft Pavement Marking Guidelines (includes information on pedestrian crossing markings) (not available on the MRWA website)
- Disability Access and Inclusion Plan 2012 - 2016
- Guidelines for Assessing Pedestrian Level of Service
- Guideline to Pedestrian and Cyclist Facilities (Doc #67-08-67)
- Guideline for Pedestrian Signals (D08#6040)
- Guidelines for Pedestrian Crossing Warrants – Working Document (not available on the MRWA website)
- Guideline for Local Area Traffic Management (D08#102211)
- Speed Zoning Policy and Guidelines (D10#87684, D10#87689, D10#92683)

3.2.3 Relevant MRWA Standard Drawings

A number of MRWA standard drawings are referenced in this Manual. These standard drawings can be found on the MRWA website, either by searching for a specific subject area or searching the list of all MRWA standard drawings:

www.mainroads.wa.gov.au

To find the complete list of MRWA standard drawings, from the MRWA home page follow the links to:

- Building Roads
- Standards & Technical
- Main Roads Drawings:
 - Standard Contract Drawings (pavement markings, lighting and sign installation)or
 - Guideline Drawings (Intersections, roundabouts, LATM)

To stay up to date with changes to MRWA standard drawings, subscribe to the MRWA automatic update service:

<http://standards.mainroads.wa.gov.au>

A list of the standard and guideline drawings referenced in this manual are provided below. It should be noted that drawings referenced in the Manual should only be viewed as an indicative layout; with specific site constraints to be considered for each individual design location. In addition, check the MRWA for any drawing updates occurring after the Manual publication.

Pedestrian Crossing Ramps

9831-5649 Ramp and Grab Rail Details

200931-0089 Directional Tactile Ground Surface Indicators - Ramp Type 'A' and 'B' Details

200931-0090 Directional Tactile Ground Surface Indicators – Modified Cut Through Corner Treatment Detail

200931-0091 Directional Tactile Ground Surface Indicators – Median Gap Details

Mid-Block Pedestrian Crossing Facilities

9120-174 Traffic Warden Controlled – Signs and Pavement Marking

9531-2169 Advance Warning Flashing Signals – School Crossing Signal Layout Signs and Pavement Markings

200331-139 Typical Treatment for Median Islands – Pedestrian refuge Island (Lane Width ≤ 5.5m)

200331-140 Typical Treatment for Median Islands – Pedestrian refuge Island (Lane Width > 5.5m)

200331-164 Signs and Line Marking for Pedestrian Zebra Crossing

200431-0116 Traffic Control Signals – Puffin and Pelican Crossings – Signs and Pavement Marking

200631-0001 Road Hump – Wombat Crossing

Lighting for Pedestrian Facilities

0448-3007 PSP Lighting Layout & Pole Schedule

0448-3008 PSP Lighting Light Pole Detail

Pedestrian Facilities at Intersections

The following drawings include some details on pedestrian facilities at different types of intersections.

200131-0084 Intersections at Grade – Sheet 4 of 8 Austroads Rural Right Turn Type ‘C’ High Entry Angle for Left Turn Slip Lane

200131-0085 Intersections at Grade – Sheet 5 of 8 – Free flow Left Turn Slip Lanes, Auxiliary Acceleration Lanes & Seagull Island Alternative Dual Carriageway in Major Road

200131-0086 Signalised intersection with Double Left and Right Turn Lanes, Dual Carriageway in Both Lanes

200431-0065 Intersections at Grade – Sheet 7 of 8 Signalised Intersections with Double Left Turn Lanes, Right Turn Acceleration Lane, Dual Carriageway in Both Roads

200331-196 Single Lane Roundabouts – Step 3 of 4

200331-201 Dual Lane Roundabouts – Step 3 of 4

200331-141 Typical Treatment for Median Island – Intersection Median Island

2000331-142 Typical Treatment for Median Islands – Left In, Left Out Partial Closure

200531-0038 Zebra Crossing at Slip Lane

200631-0002 Typical Treatment for Seagull Closures – Left Turn Entry and Exit Only

201131-0001 Typical Treatment for Entry Statements – Raised Pavement at T-Junction

3.3 Other State Government Standards and Guidelines

Objective

To outline other State Government standards and guidelines which are relevant for pedestrian infrastructure.

Key Points

Some other State Government authorities have developed design standards specific to road infrastructure.

3.3.1 Liveable Neighbourhoods (2007; updated 2009)

The Liveable Neighbourhoods policy aims to achieve more compact, better defined and sustainable urban communities.

Liveable Neighbourhoods includes technical guidelines on the planning and design of walkable neighbourhoods. This includes recommendations on the street layout and footpath width. However it should be noted the dimensions included in Liveable Neighbourhoods reflects the minimum width of the pedestrian through-route which should be provided along local roads. Local Government planning guidelines may require more generous footpath dimensions, and wider footpaths should be provided wherever possible. The dimensions in Liveable Neighbourhoods also assume all street furniture (including light poles and traffic signs) are located in the verge outside of the footpath width.

www.planning.wa.gov.au/publications/919.asp



3.3.2 Transport Assessment Guidelines for Developments

The WAPC produced a series of Transport Assessment Guidelines for Developments which outline transport issues which need to be considered and addressed in all new Structure Plans, Subdivisions or Development applications.

This identification of the impacts on existing walking and cycling access, and the provision of integrated walking and cycling facilities within the development.

The Transport Assessment Guidelines are divided into five volumes:

Volume 1 – General Guidance

Volume 2 – Structure Plans

Volume 3 – Subdivisions

Volume 4 – Individual Developments

Volume 5 – Technical Appendix

The Traffic Assessment Guidelines Volume 3 (for Subdivisions) and Volume 5 (Technical Appendix) also include guidelines on the demand for pedestrian crossing facilities.

<http://www.planning.wa.gov.au/publications/1197.asp>

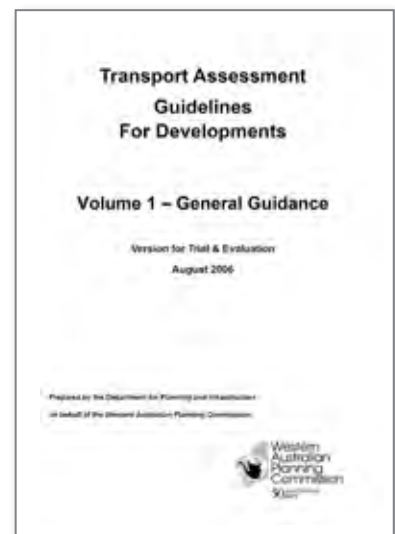

3.3.3 Public Transport Bus Stop Layout Guidelines

The Public Transport Authority (PTA) is responsible for the provision of all public transport services and facilities, and ensuring they comply with the requirements of the Disability Discrimination Act and the associated Disability Standards for Accessible Public Transport.

The objective of the Public Transport Bus Stop Layout Guidelines is to improve bus to bus stop accessibility by making the general bus stop area free of impediments that can act as mobility barriers. The Guidelines provides approved bus stop designs which include the application of tactile ground surface indicators (TGSIs) and wheelchair access at all new and existing bus stop locations.

There are other PTA Guidelines available that provide more detail on best practice approaches regarding planning public transport networks, prioritising bus services on transport networks and implementing traffic management devices along bus routes.

www.pta.wa.gov.au



3.4 Local Government Standards and Guidelines

Objective

To outline Local Government standards and guidelines which are relevant for pedestrian infrastructure.

Key Points

Some Local Government Authorities have developed design standards specific to a local area.

3.4.1 Local Government

A number of Local Government Authorities have developed policies, guidelines or standard drawings which impact the design or use of pedestrian facilities. Examples include:

- Technical design and construction notes for road infrastructure
- Safer design guidelines for designing out crime (particularly relevant for the location and lighting of pedestrian paths)
- Technical design and construction notes for road infrastructure
- Alfresco dining policies, specifying the minimum clear-width to be maintained for pedestrian access
- Lighting policies, specifying minimum lighting levels for different streets and paths
- Guidelines for construction works affecting footpaths

When working on local streets or reserves, always check with the Local Government Authority for relevant policies, guidelines or drawings. Much of this information is available on the Local Government Authority website.



3.4.2 Road Safety Around Schools Guidelines

The WA Local Government Association's RoadWise Program has produced a comprehensive package of information, tools and advice to assist Local Governments and school communities to identify and address traffic management and road safety issues around schools.

Local Governments are encouraged to use the guidelines and distribute these to schools. Support and advice on using the guidelines is available from RoadWise Regional Road Safety Officers. The guidelines also aim to assist school communities in the identification of road safety issues in their school environment and develop strategies to address these issues.

www.roadwise.asn.au/

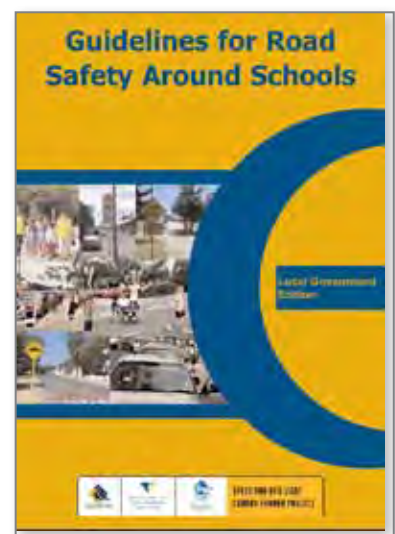

3.4.3 Walkability Audit Tool

The Walkability Audit Tool is a tool for use by officers of local government authorities, consultants and community groups to identify issues to improve pedestrian safety, accessibility and amenity. The tool can be used to help identify appropriate improvement measures and document the findings of the situation in an audit report to develop an action plan for the Council.

Walking audit tools are useful in two ways. The Tool flags what an auditor needs to check and provides a consistent audit framework to compare audit findings and outcomes. The document provides information on the steps to organise an audit and how to use the forms with supporting information when conducting an onsite audit.

www.transport.wa.gov.au/



3.5 Austroads Guide to Traffic Management and Guide to Road Design Series

Objective

To outline the range of information available on pedestrian infrastructure throughout the new Austroads Guides.

Key Points

Reference and guidance measures to assist with planning and designing streets for pedestrians is included throughout the new Austroads Guides.

3.5.1 Austroads Guide to Traffic Management Series

The Austroads Guide to Traffic Management Series (AGTM) provides comprehensive coverage of traffic management guidance for practitioners involved in traffic engineering, road design, town planning and road safety.

The AGTM series outlines the principles and considerations for designing road transport networks and is divided into thirteen parts:

- Part 1: Introduction to Traffic Management
- Part 2: Traffic Theory
- Part 3: Traffic Studies and Analysis
- Part 4: Network Management
- Part 5: Road Management
- Part 6: Intersections, Interchanges and Crossings
- Part 7: Traffic Management in Activity Centres
- Part 8: Local Area Traffic Management
- Part 9: Traffic Operations
- Part 10: Traffic Control and Communication Devices
- Part 11: Parking
- Part 12: Traffic Impacts of Developments
- Part 13; Road Environment Safety

The guides which provide the most relevant information for pedestrian networks are described in more detail in the following pages. Electronic copies of Austroads Guides are only available through a paid subscription service.

www.onlinepublications.austroads.com.au/

Part	Title	Description
Part 1	Introduction to Traffic Management	Provides an overview of traffic management and its role in road transport.
Part 2	Traffic Theory	Explains the fundamental principles of traffic flow and behavior.
Part 3	Traffic Studies and Analysis	Details methods for collecting and analyzing traffic data.
Part 4	Network Management	Discusses strategies for managing road networks to improve efficiency.
Part 5	Road Management	Covers the maintenance and operational aspects of roads.
Part 6	Intersections, Interchanges and Crossings	Provides guidance on the design and operation of various road junctions.
Part 7	Traffic Management in Activity Centres	Addresses the specific challenges of managing traffic in urban centers.
Part 8	Local Area Traffic Management	Focuses on managing traffic in residential and commercial areas.
Part 9	Traffic Operations	Details the day-to-day operational aspects of traffic management.
Part 10	Traffic Control and Communication Devices	Explains the use of traffic signals, signs, and other control devices.
Part 11	Parking	Provides guidance on the design and management of parking facilities.
Part 12	Traffic Impacts of Developments	Details how to assess and manage the traffic impacts of new developments.
Part 13	Road Environment Safety	Focuses on the safety aspects of road design and management.

Table of the AGTM Series included at the beginning of each guide

AGTM Part 3: Traffic Studies and Analysis (AGTM03/09)

Outlines the importance of traffic data and its analysis for transport planning and design. It provides guidance on the different types of traffic studies and surveys that can be undertaken, their use and application, and methods for traffic data collection and analysis.

Includes examples of pedestrian surveys in Appendix E.

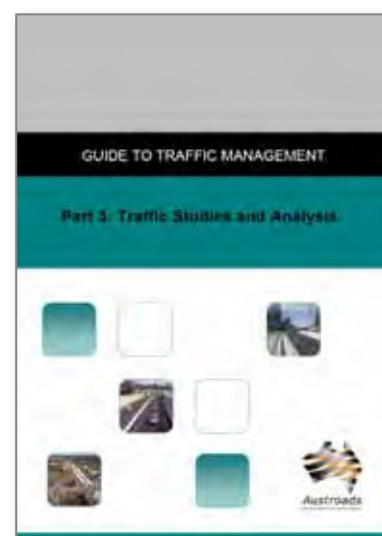

AGTM Part 4: Network Management (AGTM04/09)

Discusses broader issues and considerations for managing road networks to provide effective traffic management for all road users.

Includes a brief summary of considerations for pedestrian networks and crossings, including discussion of different pedestrian characteristics in Section 4.7.

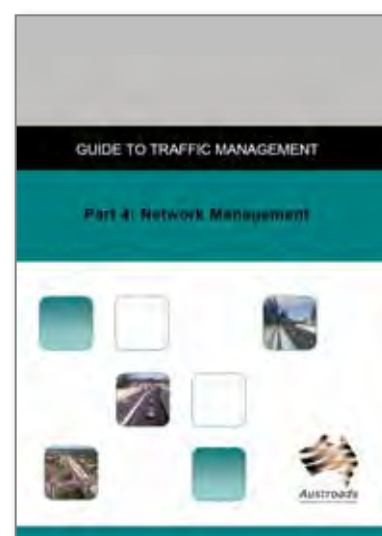

AGTM Part 5: Road Management (AGTM05/08)

Focuses on principles and issues for the management of mid-block traffic between major intersections. Includes guidance under the four key areas of access management, road space allocation, lane management and speed limits.

Includes a summary of road space considerations for pedestrians in Table 3.1 and 3.2.



AGTM Part 6: Intersections, Interchanges and Crossings (AGTM06/07)

Focuses on traffic management principles and issues and treatments related to intersections, interchanges and crossings. It includes information and guidelines on factors that need to be considered in the selection of an appropriate type of intersection and in the functional design of intersections.

Includes a summary of issues for different road users (Table 3.3), discussion on pedestrian issues at roundabouts and typical walking speeds (Section 4.5.3), a summary of all road user requirements at arterial and local road signalised crossings (Table 5.2 and 5.3), and a more detailed discussion of pedestrian crossing facilities (Section 8).

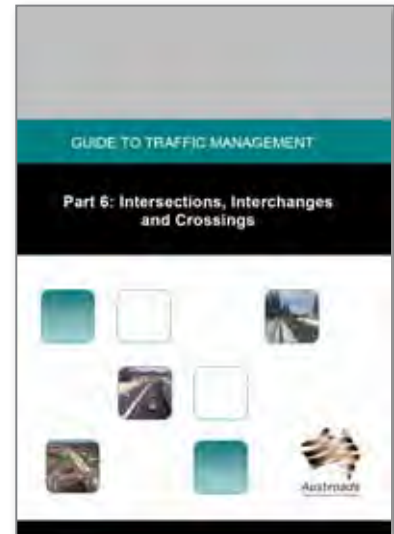

AGTM Part 7: Traffic Management in Activity Centres (AGTM07/09)

Activity Centres are characterised by high levels of activity and interaction, especially by pedestrians. Activity centres often have a focus on 'place making' or the creation of vibrant hubs which bring people together. This guide addresses the need to balance providing for vehicular access and circulation, and providing for pedestrian, cyclist and public transport needs without compromising the functionality of a site.

The guide outlines operational and physical measures for all users on road networks through activity centres. The guide includes examples of activity centres around Australia where different approaches to lowering speeds and reducing conflict have been implemented. Specific details on providing for pedestrians are included in Section 3.8.

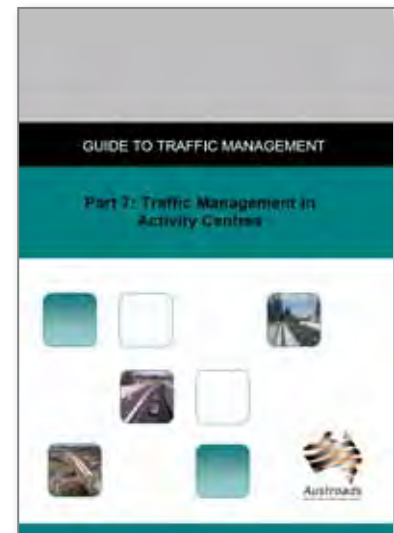

AGTM Part 8: Local Area Traffic Management (AGTM08/08)

Outlines principles, processes, issues and resource requirements for implementing Local Area Traffic Management schemes.

Includes design information and examples of a range of schemes and treatments. Lowering speed limits and discouraging unnecessary through-traffic assists with the safety and amenity of pedestrian networks.



3.5.2 Austroads Guide to Road Design Series

The Austroads Guide to Road Design Series (AGRD) provides detailed guidelines on the design of all components of a road network. The series was developed with collaboration from road authorities across Australia and New Zealand, and represent appropriate practices across these regions.

The AGRD series provides guidance on the development of safe, economical and efficient road designs and is divided into 8 sections:

- Part 1: Introduction to Road Design
- Part 2: Design Considerations
- Part 3: Geometric Design
- Part 4: Intersections and Crossings – General
- Part 4A: Unsignalised and Signalised Intersections
- Part 4B: Roundabouts
- Part 4C: Interchanges
- Part 5: Drainage Design
- Part 6: Roadside Design, Safety and Barriers
- Part 6A: Pedestrian and Cyclist Paths
- Part 6B: Roadside Environment
- Part 7: Geotechnical Investigation and Design
- Part 8: Process and Documentation

The guides which provide the most relevant information for pedestrian network design are described in more detail in the following pages.

Electronic copies of Austroads Guides are only available through a paid subscription service.

www.onlinepublications.austroads.com.au/

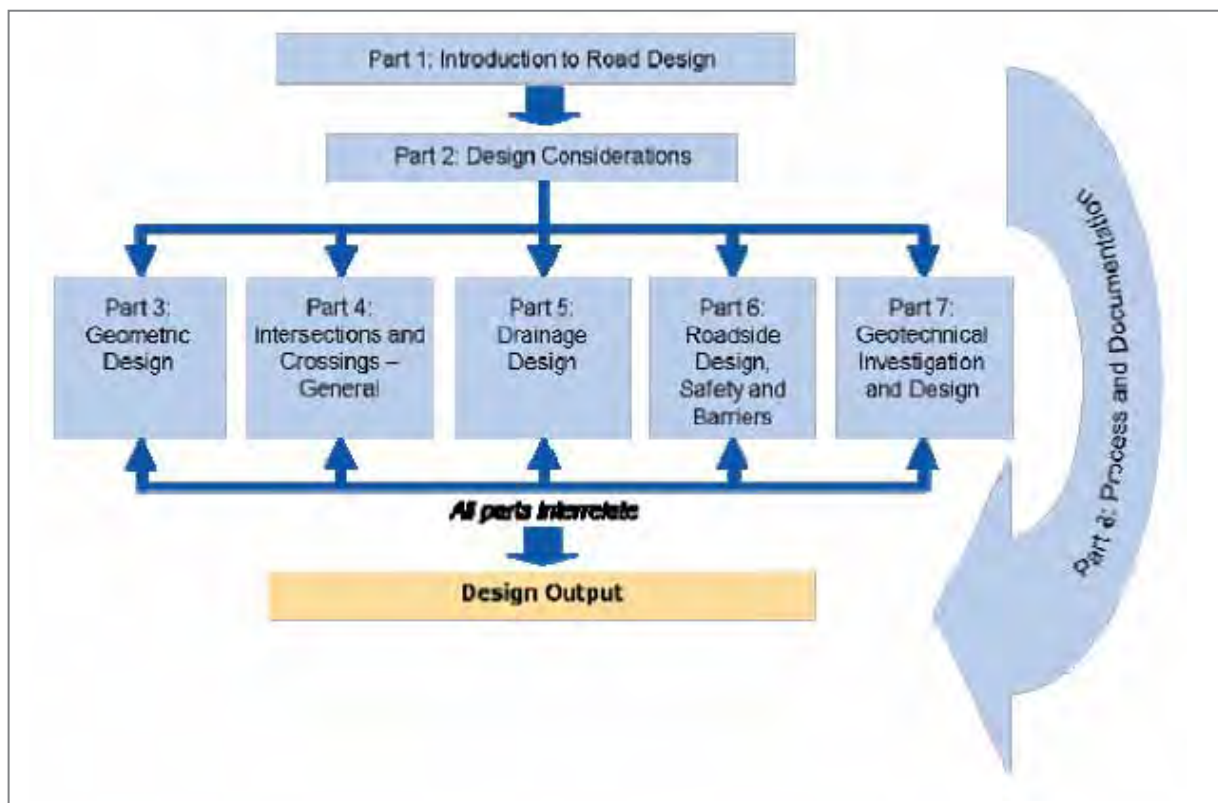

Flow chart for the AGRD Series included at the beginning of each guide

AGRD Part 3: Geometric Design (AGRD03/10)

Covers geometric design elements such as operating speed, sight distance, horizontal and vertical geometry, and consideration of cross-section widths. This includes information on the recommended lane widths and dimensions for on-road cyclist and parking facilities.

The information in this guide generally replaces that which was previously provided in the *Austrroads Urban and Rural Road Design Guides* (Austrroads 2002b and Austrroads 2003).

Includes information on assumptions used in sight distance assessments (Section 5.2.2) and Stopping Sight Distance calculations (Section 5.3).



AGRD Part 4: Intersections and Crossings General (AGRD04/09)

Provides design information on elements common to all at-grade intersections, such as design considerations for all road users, design process, choice of design vehicle, provision for public transport and property access.

This guide also provides detailed information on the selection and design of pedestrian mid-block crossing facilities (Section 8), including discussion on issues and considerations for different facilities in Commentaries 4 – 9). It also includes information on the design of railway crossings in Section 10.

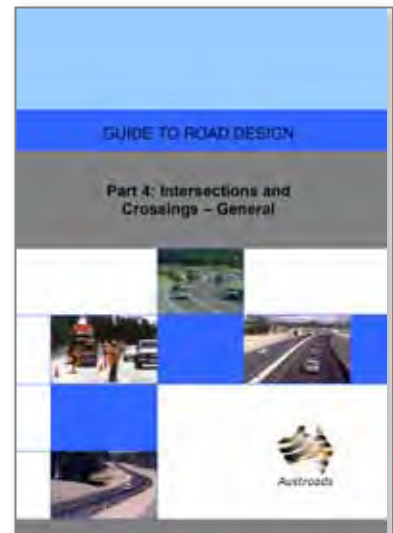

AGRD Part 4A: Unsignalised and Signalised Crossings (AGRD4A/10)

Provides guidance on the detailed geometric design of all at-grade intersections (excluding roundabouts).

Includes information on sight distances at pedestrian crossings in Section 3.3.

Also includes some information on the design of kerb radii for specific design vehicles in Section 8.3 (these radii may not be appropriate for local road intersections).

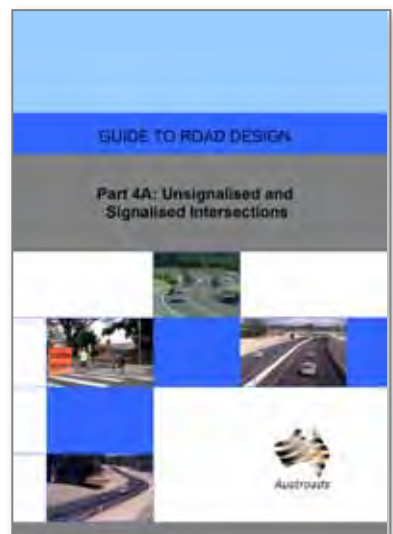

AGRD Part 4B: Roundabouts (AGRD4B/11)

Provides guidance on the geometric design of roundabouts, including design principles, procedure, and guidelines to develop safe and efficient roundabout layouts. Includes a new design method for roundabouts that focuses on the entry curvature to achieve a reduction in vehicle approach speeds rather than applying the deflection method previously recommended.

Includes design consideration for pedestrians in Section 5.2, including information on pedestrian crossing assessments.



AGRD Part 4C: Interchanges (AGRD4C/09)

The focus of this part is the detailed geometric design of the grade separations, ramps and ramp terminals associated with interchanges, particularly with respect to cross-section, design speed, sight distance, horizontal and vertical alignment, sight distance and the layouts of ramp terminals at the freeway and at the minor road.

Includes a brief discussion on pedestrian grade separated crossings in Section 4.4, and on the provision for pedestrians and grade-separated interchanges in Section 13.



AGRD Part 6A: Pedestrian and Cyclist Paths (AGRD6A/09)

Covers the geometric design of all types of pedestrian and cycling paths. This includes the design of paths in road reserves, through parkland reserves, or beside rivers or coastal areas to provide safe and convenient routes and facilities for pedestrian and cyclists. The guide includes information on pedestrian space requirements and the principles of pedestrian network planning. It does not include any information related to pedestrian crossings, this is covered in AGTM Part 6 and AGRD Part 4, 4A, 4B and 4C.

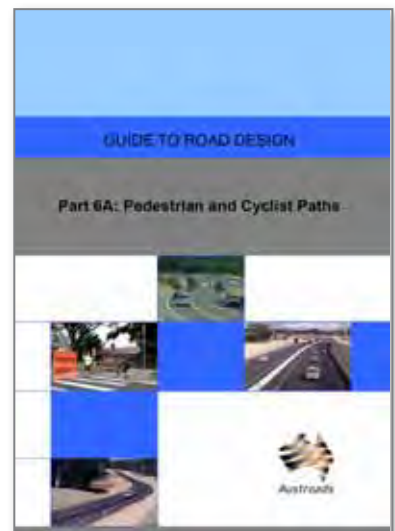

3.6 Australian Standards Series

Objective

To outline the relevant Australian Standards which include information on pedestrian infrastructure.

Key Points

Australian Standards outlines the minimum design requirements for pedestrian infrastructure.

Australian Standards

There are many Australian Standards (AS) that will be applicable when designing and constructing the pedestrian environment, including:

- AS/NZS1158 Series – Lighting for Roads and Public Spaces
- AS1428 Series – Design for Access and Mobility
- AS1742 Series – Manual of Uniform Traffic Control Devices
- AS/NZS2890 Series - Parking Facilities
- AS 5100 Series – Bridge Design

The Australian Standards referenced in this manual are summarised in the following section.

Electronic copies of Australian Standards are only available through a paid subscription service.

www.standards.org.au/

3.6.1 AS/NZS1158 – Lighting for Roads and Public Spaces Series

AS/NZS1158.1.1 – 2005 (includes Amendment 1 2009)

Part 1 - Vehicular traffic (Category V) lighting - Performance and design requirements

Lighting along arterial roads is generally required to meet the AS 1158.1.1 performance and design requirements. Reference should still be made to AS/NZS1158.3.1 to ensure lighting along adjacent footpaths meets the minimum pedestrian lighting requirements.

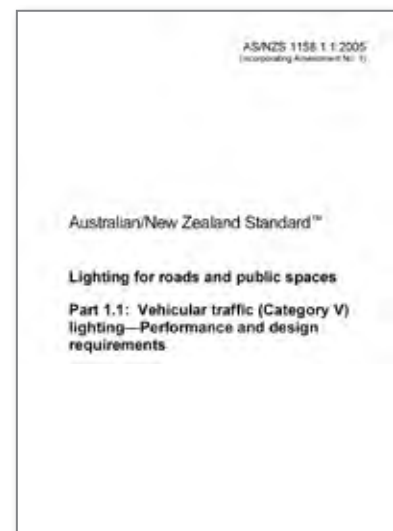

AS/NZS1158.3.1 – 2005 (includes Amendment 1 2008 and Amendment 2 2010)

Part 3 - Pedestrian area (Category P) lighting - Performance and design requirements

This standard outlines the minimum lighting performance and design requirements along local roads, paths and through public spaces. Local governments may have additional policy and design requirements.



AS/NZS1158.4 – 2009

Part 4: Lighting of pedestrian crossings

Outlines the minimum lighting performance and design requirements for pedestrian crossings, to ensure pedestrian are clearly visible to approaching motorists before entering and on a road crossing. All crossings likely to be used in the evenings and at night should meet the minimum lighting requirements to ensure the safety of pedestrians.

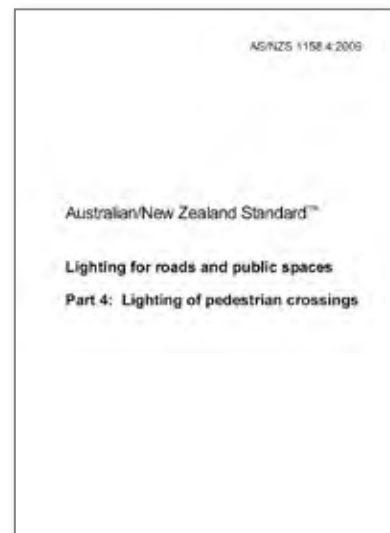

3.6.2 AS1428 – Design for Access and Mobility Series

AS1428.1 – 2009 (includes Amendment 1 2010)

Part 1: General requirements for access – new building work

A reference document that provides technical information on the design of facilities that will enable the minimal amount of access required by people with disability. This standard includes 80% of wheelchairs and 80% of users. Areas covered include specifications for providing:

- Circulation spaces
- Kerb ramps
- Ramps, steps
- Accessible toilets
- Signage



AS1428.2 – 1992

Part 2: Enhanced and additional requirements – Buildings and facilities

A reference document that provides technical information on the design of facilities that will enable access for people with disability including 90% of wheelchairs and 90% of users. This document also includes average and common reach ranges etc, for people with disability, providing valuable information for those designing non standard facilities to meet the needs of people of all ages and abilities.



AS/NZS1428.4.1 – 2009 (includes Amendment 1 2010)

Part 4: Means to assist the orientation of people with visual impairment – Tactile ground surface indicators

This document provides information on the design and application of both hazard and directional tactile ground surface indicators (TGSIs), within the pedestrian environment. It describes how these indicators compliment a system of other environmental guidance cues that assist people with a vision impairment to safely navigate around the community.

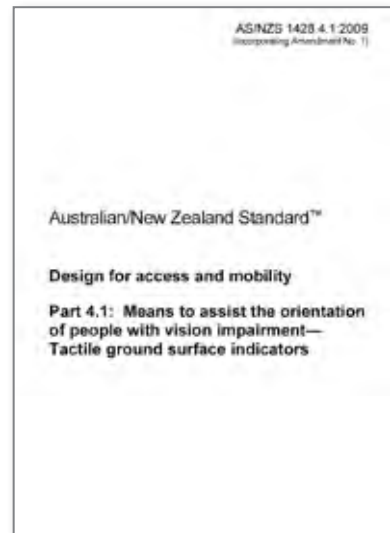

3.6.3 AS1742 Manual of Uniform Traffic Control Devices Series

AS1742.2 – 2009 (includes Amendment 1 2009)

Part 2: Traffic control devices for general use

This Standard specifies requirements for regulatory and warning signs, pavement markings and other devices for general use on roads, and sets out the way they are applied at intersections and interchanges, between intersections, and at a number of specific situations. Includes information on vertical clearances underneath signs.

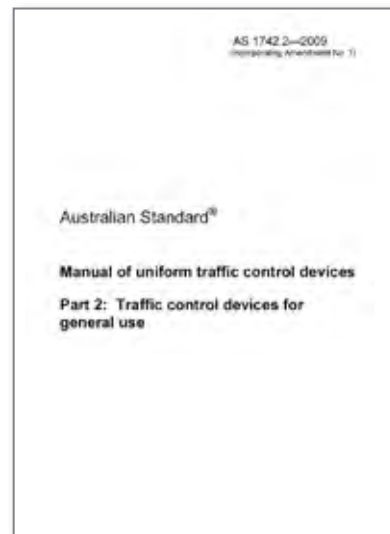

AS1742.4 – 2008 (includes Amendment 1 2009)

Part 2: Speed controls

Includes information on traffic control devices used to reduce speed through particular environments (speed zones). This includes information on shared zones and school zone signage.

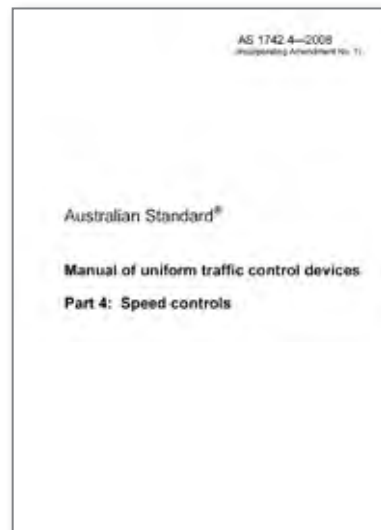

AS1742.7 – 2007 (includes Amendment 1 2007)

Part 7: Railway crossings

This Standard specifies traffic control devices to be used to control and warn traffic at and in advance of railway crossings at grade. It specifies the way in which these devices are used to achieve the level of traffic control required for the safety of rail traffic and road users, including pedestrians.

Includes layout diagrams for a number of different pedestrian rail crossing options.

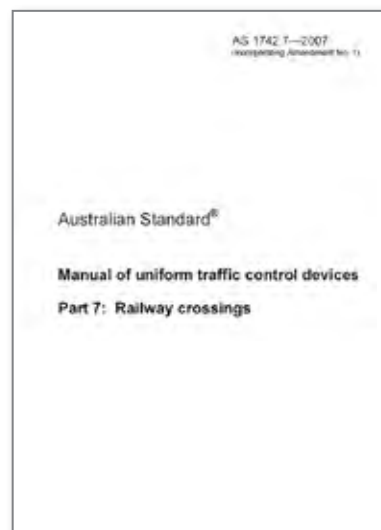

AS1742.10 – 2009

Part 10: Pedestrian control and protection

Outlines requirements for the control and protection of pedestrians, including pedestrian and children’s crossings, mid-block pedestrian actuated traffic signals, pedestrian refuges and malls.

Information on temporary pedestrian facilities at roadworks is covered in S 1742.3, and information on shared pedestrian / bicycle paths is covered in AS 1742.9.

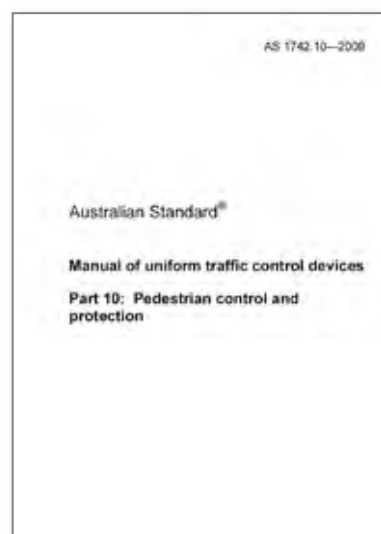

AS1742.14 – 1996

Part 14: Traffic signals

Sets out the requirements for the layout of signals and display aspects used at traffic signals.

Includes general information on pedestrian displays at traffic signals, and the placement of pedestrian push buttons.

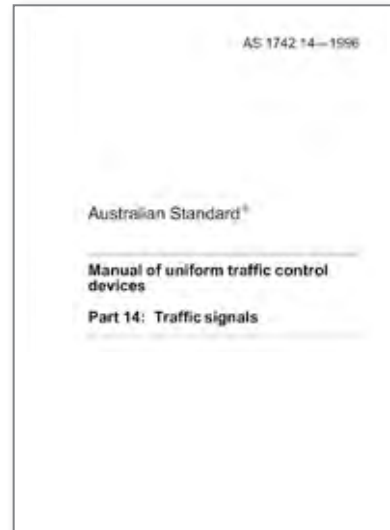

3.6.4 AS2353 Pedestrian Push-Button Assemblies

Specifies the requirements for the design, construction and performance of pedestrian push-button assemblies and associated equipment, which are designed to facilitate the safe movement of pedestrians at locations controlled by traffic signals.

Includes requirements for the generation of audio-tactile signals, for use in conjunction with push-button assemblies, to assist pedestrians who are visually impaired.



3.6.5 AS2890 Parking Facilities Series

AS/NZS2890.6 – 2009

Part 6: Off-street parking for people with disabilities

Outlines the minimum dimension and access requirements for accessible parking spaces.

The minimum supply rates for accessible parking spaces are outlined in the Building Code Australia.



3.6.6 AS5100 Bridge Design Series

AS5100.1 – 2004 (includes Amendment 1 2010)

Part 1: Scope and general requirements

(This Standard is also designated as AUSTRROADS publication AP-G15.1/04)

Provides information on the design of pedestrian bridges, including details on barriers to protect pedestrians and passing vehicles on roads or railways below pedestrian bridges.

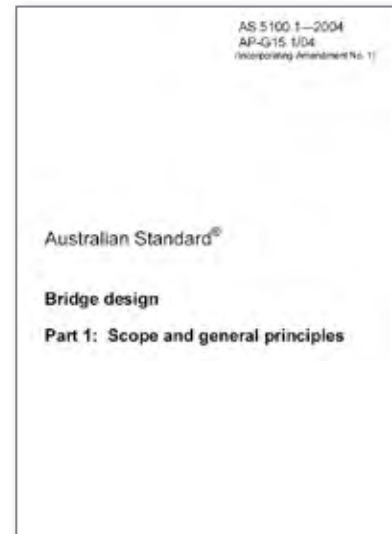

3.7 International Good Practice Examples

Objective

To highlight examples of international manuals which provide additional guidance on designing walkable neighbourhoods.

Key Points

International references should be used for guidance only, with all designs to be approved by local authorities.

These international references can be useful tools for researching pedestrian planning and design solutions.

3.7.1 Manual for Streets, UK

The Manual demonstrates how the design of residential streets can help create better places with local distinctiveness and identity. It illustrates the benefits that flow from good design and assigns a higher priority to the needs of pedestrians, cyclists and public transport. The intention is to create streets that encourage greater social interaction and enjoyment while still performing successfully as conduits for movement. It challenges some established working practices and standards that are failing to produce good-quality outcomes, and asks professionals to think differently about their role in creating successful neighbourhoods.

Manual for Streets 2, UK

Manual for Streets 2 builds on the philosophies set out in Manual for Streets and demonstrates through guidance and case studies how they can be extended beyond residential streets to include both urban and rural situations. The Manual will help everyone involved in the planning, construction and improvement of streets to deliver more contextually sensitive designs.

www.dft.gov.uk/publications/manual-for-streets



3.7.2 Context Sensitive Solutions (CSS), Institute of Transportation Engineers 2010

The Context Sensitive Approach considers the total context within which a transportation project will exist. It is a collaborative, interdisciplinary approach involving all stakeholders to develop a transportation facility that fits its physical setting and preserves scenic, aesthetic, historic and environmental resources, while maintaining safety and mobility. In the past the design speed has been encouraged to be as high as is practical. The CSS recommends that the design speed become a function of the thoroughfare type and context (i.e. residential or commercial). Setting the design speed closer to the target speeds encourages operating speeds that are appropriate and enforceable.

www.ite.org/css/



4. Legislation and Regulations

In this Section

- 4.1 Disability Discrimination Act 1992
- 4.2 Road Traffic Code 2000
 - 4.2.1 Pedestrian and Cyclist Definition
 - 4.2.2 Paths Used by Pedestrians
 - 4.2.3 Giving Way to Pedestrians
 - 4.2.4 Non-Signalised Mid-Block Crossings
 - 4.2.5 Signalised Crossings
 - 4.2.6 Crossing the Carriageway at or near a Marked Crossing
 - 4.2.7 Use of the Carriageway by Pedestrians at other than a Crossing
 - 4.2.8 Access Prohibitions
 - 4.2.9 Shared Zones
 - 4.2.10 Railway Level Crossings
- 4.3 Main Roads Act 1930
 - 4.3.1 Main Roads Act 1930

4.1 Disability Discrimination Act 1992

Objective

To describe the Disability legislation pertaining to pedestrian infrastructure.

Key Points

There are legislative requirements that relate to infrastructure for pedestrians.

The Disability Discrimination Act provides uniform protection for everyone in Australia against discrimination based on disability. The Act ensures equality before the law and promotes acceptance within the community of the fundamental rights of people with disability.



Disability discrimination happens when people with disability are treated less fairly than people without disability. Disability discrimination also occurs when people are treated less fairly because they are relatives, friends, carers, co-workers or associates of a person with disability.

The Disability Discrimination Act makes it against the law to discriminate against someone if they have a disability in the following areas of life:

- Employment
- Education
- Access to premises (which include public footpaths and walkways under the Act)
- Provision of goods, services and facilities
- Accommodation
- Buying land
- Activities of clubs and associations
- Sport
- Administration of Commonwealth Government laws and programs

Where a person believes they have been discriminated against in breach of the Disability Discrimination Act they can make a complaint to the Australian Human Rights Commission about the person, business or organisation alleged to have behaved in a discriminatory manner.

www.comlaw.gov.au/Details/C2010C00023

4.2 Road Traffic Code 2000

Objective

To outline the current traffic regulations relevant to pedestrians.

Key Points

Regulations provide a legislative framework to control the movement of pedestrians and other road users.

Traffic laws that govern pedestrians and other road users in Western Australia are contained in the Road Traffic Code 2000. These laws are intended to provide safer conditions for all road users by regulating the way the road is used.

The rules outlined in the following pages are only a selection of all the regulations contained in the Road Traffic Code.

Rules relating specifically to pedestrian and cyclist behaviour are provided in Part 14. Rules relating to motorist behaviour where pedestrians are present are found throughout the Code. Specific rules on giving way at pedestrian crossings and in shared zones are provided in Part 7.

Note: The term “pedestrian crossing” used in the Road Traffic Code has been replaced by “zebra crossing” in this paper to avoid confusion with other pedestrian crossings.

www.slp.wa.gov.au

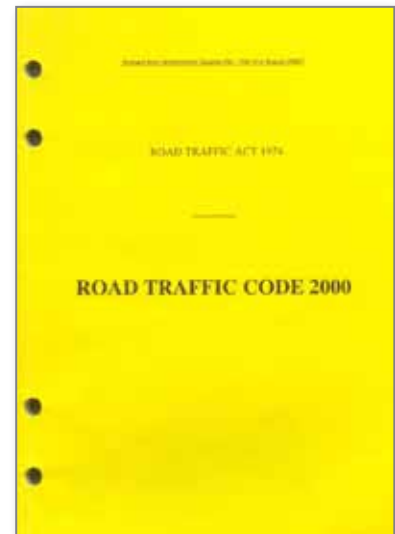

4.2.1 Pedestrian and Cyclist Definition

A pedestrian is defined as any person on foot, in a pram, or a person with disability in a unmotorised or motorised wheelchair, and includes:

- A person pushing a perambulator or wheelchair
- A person wheeling a bicycle or a wheeled toy, if the person is completely dismounted from the bicycle or wheeled toy
- A person in or on a wheeled recreational device or a motorised scooter
- A person under 12 years of age in or on a wheeled toy

More information on road rules for motorised scooters (or gophers) is available through the Department of Transport website:

Information for Gopher Users

A wheeled recreational device is defined as device used to transport a person which is propelled by human power or gravity only. The definition covers roller skates, skateboards and unicycles. All people using these devices are legally classified as pedestrians.

A motorised scooter is defined as a device with two or more wheels used by a single person and propelled by an electric motor, provided the motor is not capable of travelling at more 10km/h on level ground and the maximum motor output is 200 watts. All people using these devices are legally classified as pedestrians.

A bicycle is defined as a vehicle with two or more wheels which is propelled by human power. The Road Traffic (Bicycles) Regulation 2002 includes power assisted bikes within the standard definition of 'bicycles' which can be used on shared paths. The Road Code was amended in August 2011 to allow adults to ride a compliant power assisted bike on shared paths as well as roads with the power engaged as they are frequently used by older people with health issues and not capable of riding a standard bicycle.

4.2.2 Paths Used by Pedestrians

There are three types of paths used by pedestrians:

- Footpath
- Shared Path
- Separated Footpath

The other type of path is a bicycle path for the exclusive use of cyclists.

Pedestrians have priority over cyclists and other road users on footpaths and shared paths.

A footpath is for the use of all pedestrians and those cyclists under the age of 12 years.

Pedestrians are not required to keep left on footpaths and shared paths (although it is courteous to do so) – unless signed through pavement markings.

The Road Code also specifies that a pedestrian shall not unreasonably obstruct or prevent the free passage of any other pedestrian or cyclist on the path. However a pedestrian travelling slower than others is not considered to be obstructing the path of others [Regulation 201].



Barker Road, Subiaco

A **shared path** is for the use of all pedestrians and cyclists and is designated by signs or pavement markings



Shared path sign (R8-2)



A **separated path** is divided by some physical means into two parts; one for pedestrians and the other for cyclists. Signs or pavement markings may be used.



Separated path sign
(R8-3)



Roberts Road, Subiaco

4.2.3 Giving Way to Pedestrians

Traffic Signalised Intersections (other than a left slip lane)

A driver turning left or right at a signalised intersection is required to give way to pedestrians crossing the carriageway the driver is entering [Regulation 45(3)].

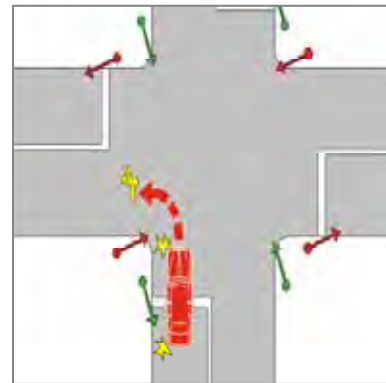

A Turning vehicle must give way to the pedestrian at signalised intersections

Intersections Without Traffic Signals (other than a left slip lane or roundabout)

A driver turning left, right or making a U-turn at a non signalised intersection is required to give way to pedestrians crossing the carriageway the driver is entering [Regulations 50(4), 52(2), 55(3), 55(6), 56(2), 56(4) and 56(6)].

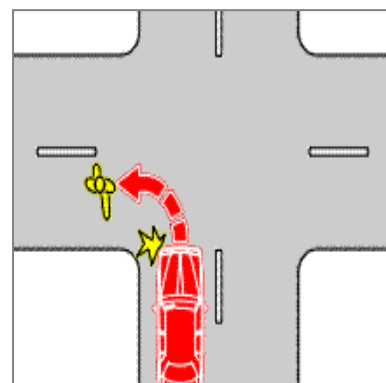

A Turning vehicle must give way to the pedestrian at non-signalised intersections

Left Slip Lanes

Unless the left slip lane is signalised, a driver is required to give way to a pedestrian crossing the slip lane [Regulations 50(5), 52(3) and 55(5)].

A driver turning left at a slip lane is not required to give way to a pedestrian crossing the carriageway the driver is entering.

Roundabouts

Turning vehicles are not required to give way to pedestrians crossing at a roundabout.

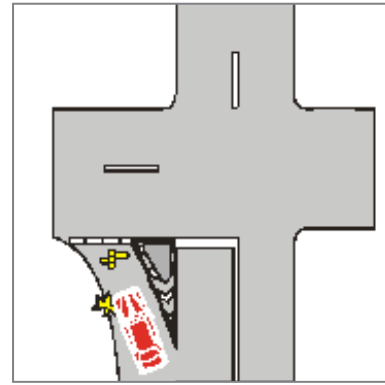

A driver must give way to a pedestrian on a left slip lane

Land Abutting the Carriageway

A driver entering or leaving the carriageway from land abutting the carriageway without a traffic signal, Stop or Give Way signs or lines is required to give way to a pedestrian on the carriageway or land abutting the carriageway (including a path) [Regulations 57(1) and 58].

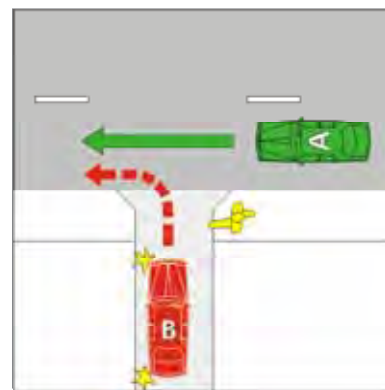

Vehicle B must give way to the pedestrian

4.2.4 Non-Signalised Mid-Block Crossings

Zebra Crossings

Drivers are required to give way to pedestrians on a zebra crossing and not to overtake another vehicle stopping or stopped at a zebra crossing [Regulations 62 and 63].

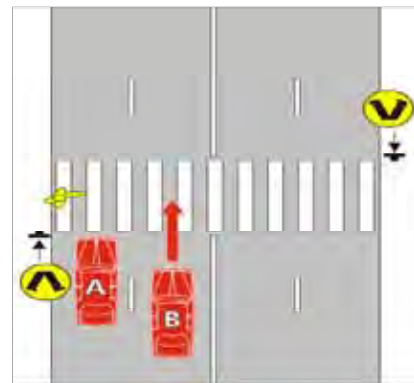

A Vehicle must not pass a vehicle that has stopped to give way to a pedestrian at a zebra crossing

Children's Crossings

A children's crossing is only in effect when a warden displays a 'children crossing stop' sign or flag [Regulations 61 and 62].



Children crossing stop sign (wardens flag) (MR-RP-9)

Stopping on or near a Non-Signalised Mid-Block Crossing

'No Stopping' applies to vehicles 20 m before and 10 m after a zebra or children's crossing unless otherwise signed. This regulation does not apply to a zebra crossing at an intersection (Regulation 144).

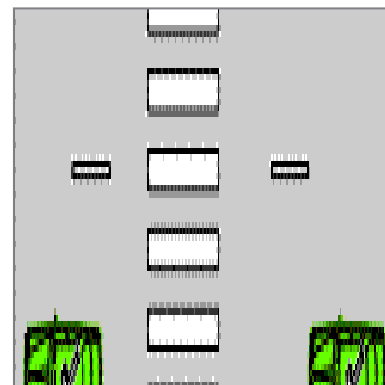

No Stopping at a zebra crossing

Stopping at or near a Median

'No Stopping' applies alongside a raised median or pedestrian refuge where there is less than 3 m between the parked vehicle and the median or double barrier line [Regulation 176(6)].

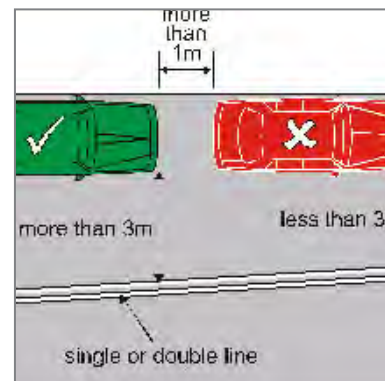

No Stopping at or near a median

4.2.5 Signalised Crossings

Pedestrian Lights

Pedestrians must not start to cross an intersection or carriageway until the pedestrian light has changed from red to green. If the pedestrian light changes to flashing red or steady red, the pedestrian should not stay longer than necessary on the carriageway and cross to the median or side of the carriageway, whichever is nearer [Regulation 197].

(Main Roads normal practice is to not provide pedestrian push buttons on medians so as to discourage pedestrians from unnecessarily stopping in the median. However, in some circumstances Main Roads will provide pedestrian push buttons in the median. In these cases the pedestrian must obey the pedestrian lanterns as per the Road Traffic Code 2000 [Regulation 197].)

Traffic Signals Without Pedestrian Lights

Pedestrians must only start to cross an intersection or carriageway if the traffic signals show a circular green signal on the road parallel to the direction of travel.

If the green signal changes to a circular red or yellow signal, the pedestrian must not start to cross or stay longer than necessary if already on the carriageway [Regulation 198].

Diagonal Crossing

Pedestrians may cross diagonally at a signalised intersection provided there is a 'pedestrians may cross diagonally' sign [Regulation 196 (2)].

(However, it should be noted the MR-RP-7 sign is not currently installed at signalised intersections in WA, removing the legal option of crossing diagonally even at sites with exclusive pedestrian phases.)



Red and green pedestrian lights



Albany Highway and Fremantle Road, Gosnells



Pedestrians may cross diagonally sign (MR-RP-7)

4.2.6 Crossing the Carriageway at or near a Marked Crossing

Pedestrians must not cross a carriageway within 20 m of a signalised or a zebra crossing except at the crossing or another crossing [Regulation 199(1)].

Pedestrians must not stay on the crossing longer than necessary except when helping another pedestrian across the carriageway [Regulation 199(2) & (3)].

4.2.7 Use of the Carriageway by Pedestrians at other than a Crossing

Crossing a Carriageway

Pedestrians are required to cross a carriageway using the shortest safe route and not stay on the carriageway longer than necessary unless pedestrians are crossing at a signalised intersection and permitted to cross diagonally [Regulation 196].

Walking Along a Carriageway

Pedestrians must not walk along the carriageway if a path or nature strip is available. If required to walk on or beside the carriageway, pedestrians are required to keep to the far right side of the carriageway and face the opposing vehicular traffic [Regulation 203].

4.2.8 Access Prohibitions

No Pedestrian Sign

Pedestrian must not walk past a 'no pedestrian' sign [Regulation 194].



No pedestrians sign (MR-RP-8)

Road Access Sign

Except in emergency situations, pedestrians must not walk along a section of road where a 'road access' sign that prohibits the use by pedestrians has been installed [Regulation 195].



Road access sign (MR-GE-25)

4.2.9 Shared Zones

Pedestrians have right of way over vehicles in a shared zone [Regulation 64]. Pedestrians are permitted to walk anywhere in shared zones and are not restricted by the normal regulations that relate to crossing carriageways.

Vehicles must not stop in a shared zone unless in a designated area or for the purpose of picking up or setting down passengers or goods or door to door delivery [Regulation 158].

The speed limit in a shared zone is 10 km/h [Regulation 11(4)].



Shared zone sign (R4-4)

4.2.10 Railway Level Crossings

Pedestrians must use a path to walk over the crossing unless a path has not been provided within 20 m of the crossing [Regulation 200].

Pedestrians must not cross a level crossing if:

- Warning lights are illuminated or flashing or bells are ringing
- A gate or barrier at the crossing is closed
- A train is approaching.



Dorothy Street, Gosnells

4.3 Main Roads Act 1930

Objective

To outline the current legislation as it relates to the responsibility of MRWA and local government in respect to the provision and maintenance of roads and footpaths

Key Points

The legislation defines the types of road that MRWA are responsible for but also by implication identifies the responsibility for other roads to lie with local government.

MRWA may also carry out improvements on secondary roads but ongoing maintenance would be carried out by local government.

It also identifies MRWA's responsibility for Traffic Signals and signs.

4.3.1 Main Roads Act 1930

The Main Roads Act 1930 sets out the responsibilities in respect of the construction, operation and maintenance of highways, main roads and secondary roads.

MRWA are therefore responsible for all works which take place on main roads and highways which would include any pedestrian facilities on their network. However the act also states that MRWA may carry out works on secondary roads following the approval of the relevant local government. The ongoing maintenance of these roads would however lie with the local authority.

The legislation also sets out the responsibility of MRWA in respect to the operation and maintenance of all Traffic Signals and signs.

The implication of this is that standards and guidelines relating to road construction must be to MRWA standards on highways and main roads, but to local government standards on other roads. However Traffic Signals and Signs should only be provided to MRWA standards and guidelines.

Section	Page
Part 1 - Preliminary	
1. Short title, commencement and terms of operation	1
2. All matters not being subject to the provisions of this Act shall be subject to the provisions of the Statutes in force at the commencement of this Act	1
3. Interpretation	1
4. Application of provisions of this Act	1
Part 2 - Commissioner of Main Roads	
5. Commissioner of Main Roads	2
6. Duties of Commissioner	2
7. Commissioner to be a body corporate	2
8. Powers and functions of Commissioner	2
9. Officers and employees	2
10. Delegation of powers of Commissioner	2
10B. Delegation by Commissioner	2
11. Officers to be subject to control of Commissioner	2
11A. Officers of Commissioner, and of officers of Corporation, not to be members of Council	2
12. Disqualification	2
Part 3 - Main Roads Advisory Board	
12A. Main Roads Advisory Board	2
12B. Main Roads Advisory Board	2

5. Land Use Planning

- 5.1 Land Use Planning
 - 5.1.1 Pedestrian Network Planning
 - 5.1.2 Pedestrian Safety and Amenity
 - 5.1.3 Urban Form
 - 5.1.4 Development Scale
 - 5.1.5 Access to Public Transport

5.1 Land Use Planning

Objective

To illustrate how land use planning can impact on the pedestrian environment.

Key Points

Design towns and residential areas that encourage walking through the provision of safe paths and easy access to shops, schools and other facilities.

Plan for mixed use centres which provide a range of services within walking distances of housing and major train stations and bus routes.

5.1.1 Pedestrian Network Planning

Pedestrian facilities have significant roles in the transport network for trips made entirely by walking and the first or last links in a trip made by other types of transport.

Inadequate provision of pedestrian networks and crossing facilities can have a large impact on overall 'connectivity' and therefore 'walkability' of a route.

Walkability is how friendly the environment is and the ease in which pedestrians can travel through this space. It includes factors such as connectivity, legibility, safety and pedestrian Level of Service.

There are five general principles for planning pedestrian networks:

- **Connected** – do walking networks provide good access to key destinations?
- **Comfortable** – does the path width, surface, landscaping and adjacent scale of development provide an attractive walking environment?
- **Convenient** - can streets be crossed easily, safely and without delay by all pedestrians?
- **Convivial** – are routes interesting, clean and free from threat?
- **Conspicuous** – are walking routes set out in a coherent network, clearly signposted and are they published in local maps?

Pedestrian networks should be planned to:

- Minimise walking distances between land uses
- Provide a clear route to entrances of large developments (rather than surrounding carpark areas)
- Avoid conflicts with vehicular movements where possible
- Provide appropriate pedestrian crossing facilities on busy roads
- Provide paths on most streets (with the exception of lightly trafficked local streets), preferably on both sides.



5.1.2 Pedestrian Safety and Amenity

Safety and amenity features of paths and streets that encourage walking include:

- Wide paths without obstructions and free from areas where people can hide
- Designing buildings which front onto streets to provide passive surveillance, avoiding car parking or low activity areas immediately adjacent to footpaths
- Convenient crossing points with kerb ramps designed for wheelchairs and prams and for people with visual disability
- Short crossing distances using kerb extensions and tight radii at intersections which also slow down turning vehicles (provided radii are sufficient for service vehicle turning movements)
- Street lighting in accordance with required standards
- Traffic calming to reduce vehicle numbers and speeds
- Shade and weather protection with trees and building canopies
- Interesting and attractive street furniture including seating and rest area
- If underpasses / grade separated crossings must be used, designing these close to pedestrian desirelines and with consideration of crime prevention principals

Development guidelines such as Designing Out Crime Planning Guidelines, Reducing Crime and Anti-Social Behaviour in Pedestrian Access Ways Planning Guidelines and the Procedure for the Closure of Pedestrian Access Ways provide guidance on good design of pedestrian networks.

Local Government may also have planning requirements applicable to the design of attractive pedestrian networks.



Safe access for all pedestrians, including those with disability



Houses facing shared paths provide passive surveillance, with shade for path users



Attractive, shaded seating areas with good passive surveillance

5.1.3 Urban Form

Plan walkable neighbourhoods near major centres and close to public transport such that walking distances are limited to:

- 400 metres or 5 minutes to town or neighbourhood centres
- 800 metres or 10 minutes to railway stations

Liveable Neighbourhoods and the Activity Centre Policy provide guidance on the placement and residential catchment sizes for different activity centres.

Locate employment, entertainment, educational institutions, health services and other major destinations in major centres to facilitate accessibility. This enables people to visit a range of services within a small area, supporting more walking trips.

Design street networks that:

- Clearly distinguish between traffic and access functions
- Have a high level of interconnection to facilitate choice of movement and dispersal of traffic
- Accommodate the needs of all road users
- Minimise through traffic movements and vehicle speeds through town centres neighbourhood areas



Neighbourhood unit based on a 400 m radius to centre



James Street, Northbridge



Rokeby Road, Subiaco

5.1.4 Development Scale

The scale of building heights and road widths impact pedestrian’s perception of the walkability of a street or public space. Important pedestrian routes should be located on streets with a ‘human scale’, where people do not feel overwhelmed by the height of surrounding buildings or by a wide, busy road environment.

Introducing landscaping and street art into a wide street can provide pedestrians with elements which are not overwhelming in height or width, and which are designed for pedestrian’s amenity. Widening footpaths can also improve pedestrian amenity along busy roads with tall buildings, as can creating framed vistas along the length of a street to break up a long, monotonous streetscape.

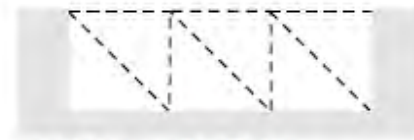

Recommendations for Height to Width Scale Ratios provided in the UK Manual for Streets
(UK Department for Transport)

5.1.5 Access to Public Transport

Medium and high density residential and mixed use development is more efficiently serviced by public transport. Access to bus stops and train stations and the amenity of these facilities influence the walkability of an area.

New developments are often assessed by the proportion of residential properties with access to a bus stop within a 400 m walk (5 minutes) or access to a train station within an 800 m walk (10 mins).

New or upgraded activity centres are required to be located on public transport routes, either bus routes for neighbourhood and district centres or major train and bus interchanges for strategic and secondary centres.



Hampton Road, South Fremantle

Safe pedestrian roads are also to be provided between transport stops and schools.

Routes to stations require surveillance and adequate lighting to provide night time safety. Passive surveillance can be provided by housing and uses that are open at night (eg. delis, service stations, recreational centres).

Planning strategies such as Directions 2031 and Activity Centre Policy highlight the importance of incorporating high quality public transport access into new development.

Policies such as Liveable Neighbourhoods, Development Control Policy 1.6 Planning to Support Transit Orientated Development and Designing Out Crime Planning Guidelines provide further design guidance, as does the PTA Designing and Planning Guidelines for Public Transport Infrastructure.

6. Pedestrian Characteristics

- 6.1 Pedestrian Characteristics
 - 6.1.1 Characteristics
 - 6.1.2 Fit Ambulant
 - 6.1.3 Young Children
 - 6.1.4 Pedestrians with Prams
 - 6.1.5 Seniors
 - 6.1.6 Vision Impairments
 - 6.1.7 Hearing Impairments
 - 6.1.8 Cognitive Impairments
 - 6.1.9 Limited Walking Ability
 - 6.1.10 Wheelchair Users
 - 6.1.11 Typical Walking Speeds
 - 6.1.12 Universal Design

6.1 Pedestrian Characteristics

Objective:

To outline the characteristics of the various types of pedestrians in order to assist designers understand the rationale for design features.

Key points:

Designing pedestrian facilities for people with a range of disability will generally assist all pedestrians.

6.1.1 Characteristics

Pedestrian facilities are often designed to cater for the 'average' pedestrian. In reality all pedestrians will fall into one of the categories below for some time within their lifespan. It is often people who do not fall within this 'normal' range, who are unable to drive cars and are highly dependent on pedestrian facilities. For this reason facilities must be constructed to accommodate uses of all ages and abilities.

Information on the characteristics and space requirements of a range of pedestrians can be found in the following sources:

- Access Resource Kit - Creating Accessible Communities - Part 1 describes characteristics of different disability
- AGTM Part 4 – Section 4.7 describes the needs of different pedestrians
- AGTM Part 6 – Section 4.5.3 describes different walking speeds (page 48)
- AGRD Part 6A provides information on average body dimensions (Section 4.1.2) and space requirements (Section 6.2)
- AS 1428.2 – 1992 – Design for Access and Mobility Part 2 sets out requirements for the design of building and facilities

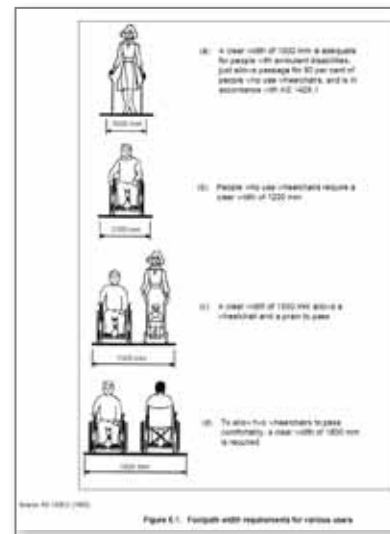

Examples of the minimum space requirements for pedestrians with different characteristics

Source: AGRD Part 6A Figure 6.1

6.1.2 Fit Ambulant

It is difficult to characterise a 'normal or average' pedestrian. Factors such as the time of day, weather conditions, purpose of the trip and relative crowds will impact a person's cognitive and perceptual decision making capacity. Given that a person's thought processes and behaviours are often a reaction to these factors, designing for people with disabilities can be extremely beneficial to the safety of all pedestrians.



William Street, Perth

6.1.3 Young Children

Young children are often considered to be smaller adults, however they have special characteristics that require specific design considerations:

- The smaller size limits their ability to be seen and see from the kerb
- Children do not have the perceptual or cognitive capacity to make sound judgements about traffic safety until about 12 years of age

Often a false sense of confidence and security means they are at a higher risk in the pedestrian environment.



6.1.4 Pedestrians with Prams

Pedestrians pushing prams or other wheeled devices have several design considerations:

- Pushing a wheeled device can slow walking speeds
- Kerb ramps are needed at all intersections and crossing facilities
- Path and ramp gradients impact the ease of walking
- Larger waiting space is required in refuges and at intersections



6.1.5 Seniors

There are many fit able bodied seniors who would fit into the category of the fit / ambulant pedestrian. However, as we age there is a higher possibility that we will acquire a disability. Statistics show that by the time people are 65 years of age there is currently a 50% chance of having a disability. The disability could be mild to severe of any one disability, or a combination of any disabilities that are discussed below.



6.1.6 Vision Impairments

This group includes people with low vision or blindness. Each category and in fact each individual will have differing functional capabilities. However the correct use of tactile ground surface indicators (TGSIs) will impact on everyone.

Vision Impairment

Vision impairment is often referred to as 'low vision'. Pedestrians with vision impairment may have decreased visual acuity, blurred vision, tunnel vision, 'colour blindness' and difficulty with glare. Therefore visual information must be clear and designed to accommodate all needs.

Blind

Pedestrians who are blind will generally be orientated to an environment before attempting to independently navigate.

Tools such as a guide dog, a white cane, electronic navigation devices or a sighted guide may be used. All of these will require increased circulation space.

Pedestrians who are blind maximise the use of their senses other than their vision, such as smell, hearing and touch to assist them to orientate to their environment. Therefore surroundings that impact on other senses need to be carefully considered.



Wellington Street, Perth



6.1.7 Hearing Impairments

People who are deaf or have partial hearing may be unable to hear on coming traffic or hear public information that is disseminated in the auditory form. They are reliant on visual information.



6.1.8 Cognitive Impairments

This group includes people with low vision or blindness. Each category and in fact each individual will have differing functional capabilities. However the correct use of tactile ground surface indicators (TGSIs) will impact on everyone.

This group of pedestrians include conditions such as intellectual disability, acquired brain injury and some types of psychiatric disability. These people may have trouble in interpreting information, making sound judgements about their safety, processing complex information and traffic systems, or reading signs.

Simple, logical, clear designs and way finding information is required to assist in negotiation of the pedestrian environment.

6.1.9 Limited Walking Ability

This group of pedestrians may not be easily recognisable because, if they do not have a walking stick or walking frame, they may not appear to be any different to the fit ambulant pedestrian.

Those who use a walking stick or a walking frame will require added circulation space to move around.

This group of pedestrians may fatigue easily and will require significantly more opportunities to rest than others.

Other issues that this group of users may experience are difficulty bending, difficulty in reaching with their arms, difficulty in grasping or manipulating controls, incoordination, tremor, difficulty in moving the head. If slopes are too steep, those using walking frames could lose their balance when going up or down a ramp.

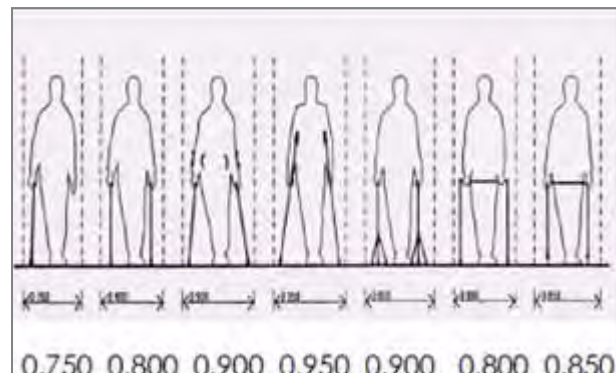

Circulation width for people with an ambulant disability

Source: Main Roads Infrastructure for Pedestrians 2004

6.1.10 Wheelchair Users

Wheelchairs can be either manual or battery powered. Battery powered scooters also fit within this area.

The footprint or minimal clear floor space required to accommodate a single stationary wheelchair is 0.8 m in width and 1.3 m in length and so will require significantly increased space to move around the environment. Scooters do not necessarily fit within this footprint.

Wheelchairs come in many styles, sizes and designs and are capable of performing differently in varying conditions depending on the user's specific requirements. For example sports style manual wheelchairs are much more manoeuvrable and can travel faster, requiring less energy than the style of manual wheelchair used to push a more dependent user. Some wheelchair users, depending on their disability, can experience pain when travelling over rough or uneven surfaces.

Manual wheelchairs

Users of manual wheelchairs can become fatigued when required to travel long distances. The energy required is significantly increased when a slope or cross slope camber involved, hence the requirement for resting landings.

Safety can be compromised when travelling down a long ramp if the slope is not covered. The surface of the slope becomes slippery and the hands can slip on the push rims when trying to control the speed. As the braking mechanism is manually operated, it is possible for a manual wheelchair user to lose control when descending a slope.



Stability is particularly important and on uneven surfaces where one or even two wheels lose traction with the ground, the chair is capable of tipping.

Other things that can be a problem for manual wheelchair users are that the footplates can 'bottom out' if the angle at the base of a ramp is too steep, they can tip backwards if a ramp is too steep, the front castors are often unable to mount a small lip and the user could be thrown out with a sudden stop at the base of a kerb ramp or a change of level in the footpath.

Battery powered wheelchairs

These wheelchairs are usually controlled by a joy stick and can travel up to 20 to 30 kms before the battery requires to be recharged.

Although travelling distances is not a problem a power chair can require significantly more circulation space than a manual wheelchair. Newer styles with a mid-wheel drive are able to turn in much smaller spaces than was previously possible; however, this can be offset by the seemingly increased size of many power wheelchairs.

Power wheelchairs are extremely heavy, so should not be lifted and they will not be able to be manually tipped to mount even a small step. It is possible to tip a powered chair if the ground is particularly uneven and wheels lose contact with the ground surface.

Battery powered scooters

These scooters can be very large and even when designing to the AS1428.2 – 1992 there is no guarantee that the facility will provide the required circulation space.

Most users of scooters are able to walk short distances and use their scooter when travelling outside only.

6.1.11 Typical Walking Speeds

Walking speeds influence the distance pedestrians can comfortably travel and have a significant impact on the ease and safety of road crossings. Slower pedestrians will require a longer gap between vehicles to safely cross a road. Consideration of pedestrian characteristics specific to each site is important to assess network and crossing requirements.

The average walking speed for a fit adult is 1.5 metres per second (m/s). Walking speeds for elderly pedestrians or pedestrians with mobility impairments can be 1.0 m/s to 1.2 m/s. These slower walking speeds represent the 5th and 15th percentile walking speeds for all pedestrians.

When assessing crossing sites, a walking speed of 1.2 m/s is generally adopted, covering 85% of pedestrian walking speeds. However at sites which are known to have higher proportions of slower moving pedestrians, a walking speed of 1.0 m/s can be adopted.



6.1.12 Universal Design

When considering pedestrian facilities, it is no longer appropriate to provide separate or add on facilities for different categories of users. It is internationally believed that pedestrian facilities should embrace the concept of Universal Design to effectively remove barriers and allow inclusion of people of all ages and abilities.

Universal Design is defined as ‘the design of products and environments to be usable by all people to the greatest extent possible, without the need for adaptation or specialised design.’

Universal Design benefits everyone, not just people with disability. For example, a ramp that is incorporated into a building’s main entrance and wider doorways not only aid wheelchair users but are also better for people with prams.

In order to meet this criteria there are many publications that need to be referenced during the design and construction stage. In addition, feedback from user groups is always extremely useful to ensure all users’ needs are being considered.

As the population ages, the incidence of disability will increase, and Universal Design will become even more important.



7. Pedestrian Paths

In this Section

- 7.1 Path Widths
 - 7.1.1 Path Audit Tools
 - 7.1.2 Types of Path Facilities
 - 7.1.3 Location of Paths
 - 7.1.4 Path location - Factors for consideration
 - 7.1.5 Zones Associated with Footpaths
- 7.2 Street Furniture
 - 7.2.1 Placement of Street Furniture
 - 7.2.2 Colour
 - 7.2.3 Seating
 - 7.2.4 Bins
 - 7.2.5 Drinking Fountains
 - 7.2.6 Telephones
 - 7.2.7 Street Trees and Vegetation
 - 7.2.8 Bus Stop Shelter and Signs
- 7.3 Grates / Covers
 - 7.3.1 Grates
- 7.4 Vertical Clearances
- 7.5 Surfaces
 - 7.5.1 Paved Path Surfaces
 - 7.5.2 Crossfall and Camber
 - 7.5.3 Drainage
- 7.6 Gradients and Ramps
 - 7.6.1 Footpath Definition
 - 7.6.2 Ramp Definition
 - 7.6.3 Length of Ramps
 - 7.6.4 Width
 - 7.6.5 Ramp and Footpath Landings
 - 7.6.6 Landing Dimensions
 - 7.6.7 Handrail Positions on Ramps
 - 7.6.8 Handrail Details
 - 7.6.9 Edge Treatments
 - 7.6.10 Warning Tactile Ground Surface Indicators (TGSI)
- 7.7 Steps and Stairs
 - 7.7.1 Geometry
 - 7.7.2 Nosing
 - 7.7.3 Handrail Details
- 7.8 Crossovers / Driveways
 - 7.8.1 Warning TGSI
- 7.9 Barricades (including chicanes and bollards)
 - 7.9.1 Chicanes and Mazes
 - 7.9.2 Temporary Barricades

7.1 Path Widths

Objective

To illustrate the requirements for providing a safe clear path of travel for all pedestrians.

Key Points

A pedestrian through-route should not be obstructed by signs, street furniture or overhanging vegetation.

The minimum through-route width should be based on the demand and mix of users using the path.

Paths should conform to minimum dimensional requirements to provide for the safe passage of pedestrians and other eligible road users.

The minimum required path width varies from case to case. Footpaths can accommodate functions other than providing a clear access route for pedestrians, such as providing space for street furniture, alfresco dining, signs and lighting poles. These temporary or permanent features reduce the effective width for pedestrians. The total footpath width must be wide enough to accommodate these other elements alongside the minimum pedestrian through-route width.

The different types of paths used by pedestrians are described in the following sections, along with design information such as recommended placement, width, gradient and clearances. Lighting is also an important element of path design, with information provided in Section 10.1.



Hay Street, Perth

Demonstrates a clear pedestrian through-route maintained alongside the building line (frontage zone).

7.1.1 Path Audit Tools

There are several simple audit tools produced by the Western Australian State Government.

Walkability Audit Tool

Provides a simple audit tool for assessing the safety, accessibility and amenity of existing paths, and identifying appropriate solutions. The audit tool is available from the Department of Transport website:

www.transport.wa.gov.au/mediaFiles/WALK_P_Walkability_Audit_Tool.pdf

Guideline for Assessing Pedestrian Level of Service

This guideline was produced by MRWA. The guideline includes measures of the path quality (width, surface, crossing and access facilities), the path location (connectivity, amenity) and mix of path users. A scoring system is used to determine the pedestrian level of service.

Access Resource Kit

Provides simple checklists and reference guides to assess the provision of appropriate facilities for people with disability. The resource kit includes specific guidance on the design of transport facilities (Section 3.49). The resource kit is available from the Disability Services Commission website:

www.disability.wa.gov.au

Human Rights Commission Design Summary

The Human Rights commission have produced a useful summary of common issues and mistakes when installing facilities for people with disability, including handrails and signage:

www.hreoc.gov.au/disability_rights/buildings/good.htm



Walkability Audit Tool (DoT)



Access Resource Kit (DSC)

7.1.2 Types of Path Facilities

Footpaths

The most common type of path is a dedicated footpath. Footpaths are solely for the use of pedestrians with the exception of cyclists under the age of twelve. Footpaths provide an important role in the transport network for trips made entirely by walking and the first or last links in a trip made by other types of transport.

Options for the location of footpaths within the road reserve are summarised in the next pages, including advantages and disadvantages for each option.

The legal use of footpaths is outlined in Section 4.2.



Shaded Footpath along Rokeby Road, Subiaco

Separated Footpaths and Cycle Paths

Separate paths are provided when the volume of both cycling and pedestrians are high, or there is a high demand for faster cyclists (such as commuter cyclists). In these circumstances a shared path would be likely to result in safety and operational issues.

A separated path is a path where cyclists and pedestrians are required to use separate designated paths, designated by the use of pavement markings, contrasting surfaces, and the erection of regulatory signs.

Separated paths are used in busy pedestrian areas (such as through the centre of Subiaco), safely merging into a shared path where pedestrian volumes reduce.

The design of separated paths is outlined in:

- AGRD Part 6A - Pedestrian and Cyclists Paths.

The legal requirements for regulatory signs and markings on shared paths and the legal use of shared paths is outlined in Section 4.2.



Separated Footpath and Cycle Path, Roberts Road, Subiaco

Note: Generally cycle paths are constructed with an asphalt pavement surface; alternating brick paving and asphalt surfaces are used at this site to warn cyclists about the approaching conflict area

Shared Paths

Shared paths allow for both pedestrians and cyclists to travel in the same space. These are appropriate in the following situations:

- The demand for both pedestrians and cyclists is sufficient to provide a facility but the intensity is expected to be not too great to provide separate facilities.
- Pedestrians and cyclists mix, but cyclists must give way to pedestrians.
- An existing low-use footpath can be upgraded to provide for cyclists by satisfying legal and adequate width requirements.
- The path should be wider than a dedicated footpath and have kerb ramps and regulatory signs or pavement markings.

The legal requirements for regulatory signs and markings on shared paths and the legal use of shared paths is outlined in Section 4.2.

A significant issue associated with shared paths is the variety of users who display various characteristics that can lead to conflict between them. These characteristics include differences in speed, space requirements, age, user expectation (as some users expect exclusive or priority use) and predictability (e.g. cyclists, pedestrians walking dogs, rollerbladers, and skateboard riders). To reduce conflict on shared paths, on-road or alternative facilities should be provided for faster cyclists.

There are specific design features for shared paths to provide a safe environment for all the users. Design details which differ between footpaths and shared paths include path overhead and side clearances, forward visibility, and the design of path intersections and path terminal treatments. The following documents provide extensive detail on the design of shared paths:

- AGRD Part 6A - Pedestrian and Cyclists Paths.
- Pedestrian-Cyclist Conflict Minimisation on Shared Paths and Footpaths (Austroads, 2006).



Shared path adjacent to Claremont Train Station



Claremont Train Station, treatment of shared path approach to pedestrian crossing

	Local Access Path	Commuter Path	Recreational Path
Desirable minimum width	2.5	3.0	3.5
Minimum width – typical maximum	2.51 – 3.02	2.51 – 4.02	3.01 – 4.02

1. A lesser width should only be adopted if there are low cyclist volumes and speeds
2. A greater width may be required where there is a high number of cyclists and pedestrians or a high probability of conflict between users

Source: AGRD Part 6, Table 7.4

7.1.3 Location of Paths

Paths can be located:

- Through road and street reserves
- Along river and coastal frontages
- On foreshores
- Through parkland
- Along railway reservations
- Abutting bridges or across exclusive bridge facilities

Within a road reserve a path can be located:

Adjacent to the property boundary

- This location presents visibility constraints at driveway crossings (must be a minimum of 3 m clearance between boundary walls and shared paths to allow for motorist sight lines) and may require deviation at side streets.
- This location can allow for verge parking.



Shared path adjacent to Riverside Drive, Perth



Barker Road, Subiaco

Adjacent to the kerb

- This location can reduce amenity and increase potential conflict with adjacent traffic, as well as conflict with street furniture located at the kerb edge such as light poles and traffic signs.
- There is also potential conflict with temporary hazards such as short-term parking (particularly for shared paths) and weekly wheelie bin collection.
- Narrow paths can also conflict with other pedestrian facilities located at the kerb edge such as kerb crossing ramps and grab rails.



Peach Street, North Perth

At an intermediate point, e.g. 1.5 m behind the kerb

- Where there is adequate space, locating a path with a verge on either side presents an attractive and safe environment for pedestrians.

However, the road reserve may be too narrow to allow a choice in the location of a path. The AGRD Part 6A details the following safety considerations when designing paths in different locations:

- There should be adequate clearance between the road traffic and path users to give a sense of distance from fast moving traffic. An extra 0.5 m width allows for a narrow 'street furniture' zone to separate the pedestrian through-route from traffic lanes.
- There should be adequate clearance from the property line to achieve sufficient sight distance for vehicles exiting driveways (3 m clearance for shared paths).
- The path should not be too far from the adjacent carriageway such that path users are outside the peripheral vision of turning drivers.



Oxford Street, Leederville



Hampton Road, South Fremantle

7.1.4 Path location - Factors for consideration

Close to kerb

- In many cases is the only option because of the road reserve width available.
- Offers the best visibility of path users to drivers reversing out of their properties, particularly where high screen walls exist at the boundaries.
- Will be used in two directions and allows cyclists to run off the path and ride against the flow of motor traffic on the road pavement. Overseas experience has shown wrong-way movements to be a major problem (Cross and Fisher 1977).
- May result in parked cars being a hazard to cyclists due to the opening of vehicle doors into the path.
- May result in persons entering and exiting parked cars being put at risk due to the proximity of bicycle movements to the cars.
- Follows the longitudinal profile of the kerb and is therefore generally cheaper to construct because of reduced earthworks.
- May be preferred by abutting landowners in terms of privacy and nature strip disruption.
- May result in the effective path width being reduced by kerb returns (however, the use of AS 1428.1 style side ramps (see Figure 8 in AS 1428.1) would be of some assistance at driveways or the path profile being adversely affected at the cross over.
- If wide, may be viewed as detracting from the appearance of the streetscape and may imply a higher speed environment.
- Is less pleasant for cyclists because of traffic noise, fumes and speed, and perhaps the splashing of water from gutters.
- May be relatively unaffected by the presence of fences varying in height and type, or having sharp or exposed edges or protrusions.

Near property boundary

- Provides a more pleasant cycling environment and is perceived to be safer for inexperienced or young cyclists.
- May limit visibility of path users to drivers reversing out of driveways, or to drivers turning left from the abutting carriageway, where path users are beyond the driver's peripheral vision.
- Does not necessarily follow the kerb profile and may result in steeper gradients for cyclists or be more costly to construct.
- May be viewed as having a lower negative visual impact on the street than a kerbside path.
- May be unacceptable to abutting land owners.
- Is more efficient for the mail service, if the nature strip is very wide.
- Should preferably be deviated to a location at least one car length back from road intersections, adjacent to which the path crosses, to facilitate passage behind a queued car).
- Allows space for garbage (e.g. wheelie) bins to be accommodated clear of path and for pit lids for utilities to be located outside of the path surface. Pit lids should not be located within paths as they can create an uncomfortable ride and constitute a trip hazard for pedestrians.

Factors considered in the choice of path alignment in road reservations

Source: AGRD Part 6A, Table 5.1

7.1.5 Zones Associated with Footpaths

There are different functions and zones which exist within a footpath cross-section which inform the required footpath width:

- **Kerb zone** – defines the limit of the pedestrian environment and is a major tactile cue for pedestrians with visual impairment
- **Street furniture zone** – used for soft landscaping, vegetation, light poles, traffic signal poles, seats, etc.
- **Through-route** – used for pedestrian travel and should be kept free from obstructions
- **Property frontage zone** – generally not used for pedestrian travel as it may contain retaining walls, fences, pedestrians emerging from buildings, ‘window shoppers’ or overhanging vegetation

The property frontage zone can also provide an important guidance measure for pedestrians with visual impairments. Building walls or landscaping adjacent to paths provides a ‘shoreline’ to follow for people using a cane. This cue enables these pedestrians to stay aligned with the footpath edge.

In shopping and ‘Main Street’ areas, the property frontage zone can be used for the placement of goods, signs and alfresco dining. This presents a conflict for pedestrians with visual impairments, if other features are not incorporated into the frontage zone to provide an alternative ‘shoring’ cue. Providing temporary or permanent fencing, or landscaping along the edge of alfresco dining areas can replicate a building edge.

Alternatively, some Local Government’s require the pedestrian through-route to be retained alongside the property frontage zone, with the alfresco dining, signs and goods placed on the outside of the through-route (within the street furniture zone). This layout also improves access to shop entrances and can improve visibility of goods on display from inside a shop.

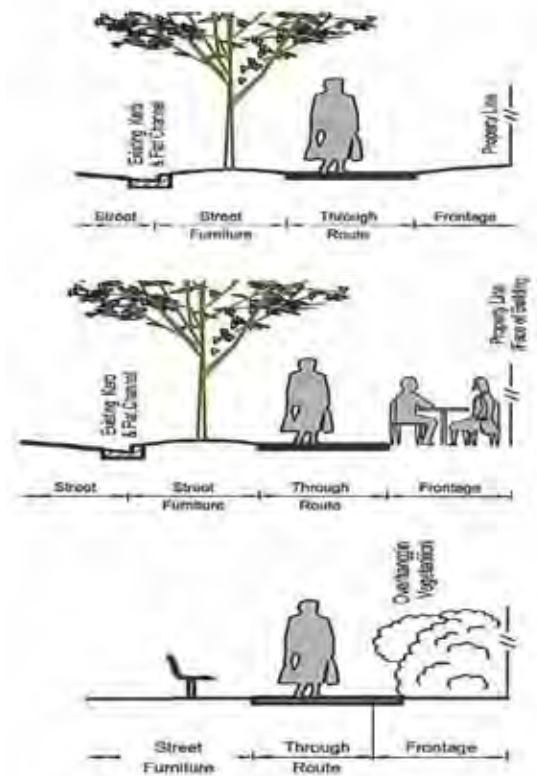

Examples of Footpath Zones

Source: AGRD Part 6A

Note: The second option does not address the role of the frontage zone in providing a guidance cue for pedestrians with visual impairments



Rokeby Road, Subiaco

Demonstrates a clear pedestrian through-route retained alongside the building line (frontage zone).

Useable Width for Through-Route Zone

The width of the footpath is dependent on the location, purpose and expected demand. The operating space for pedestrians with impairments or mobility devices needs to be considered.

The minimum and desired width for the pedestrian through-route zones in various situations are summarised below and detailed in WA Liveable Neighbourhoods and Austroads Guide to Road Design Part 6A. Wider path widths should be provided where possible, rather than simply designing for the minimum through-route width.

- 1.2 m is the absolute minimum through-route width allowing passage for a single wheelchair (this minimum width should only be used for a short distance in constrained environments).
- 1.8 m is the desired minimum path width (1.5 m absolute minimum) to allow for two wheelchairs to comfortably pass, widened to 2 m near schools and small local shops.
- 1.54 m wide clearance should be maintained between a bus shelter and the kerb, as specified in the Public Transport Bus Stop Layout Guidelines, where insufficient space is available the absolute minimum through-route width is 1.2 m.
- 2.4 m desirable minimum through-route width (or higher based on demand) for commercial or shopping environments
- In busy alfresco dining areas such as the central city area, a minimum through-route of 3 m - 4 m should be provided (such as the requirements of the City of Perth, Alfresco Dining Policy), reduced to 2.5 m in areas with less pedestrian traffic



Hampden Road, Nedlands

The bus stop sign is placed in front of the shelter to allow for a wheelchair to negotiate around these features, however the through-route past the bus stop may be less than 1.2 m (impeding wheelchairs / mobility scooters)



Guger Street, Claremont

The through-route past this fence is less than 1.0 m, presenting a major barrier for pedestrians with disability or prams



Goderich Street, Perth

Demonstrates a clear pedestrian through-route past the bus stop allowing access for wheelchairs / mobility scooters

To maintain an acceptable footpath width, objects such as poles, bollards or chicanes, bus shelters and accompanying signage should be located within either the Street Furniture Zone or the Frontage Zone, so as to keep the Through-route Zone free for pedestrians, particularly those using wheelchairs and those with low vision.



Belmont Avenue, Belmont

The telecommunications dome is located within the through-route with poor colour contrast - creating an obstacle for people with low vision.



Howard Street, Perth

Using clear-stem street trees reduces the impact on the pedestrian through-route, whilst adding shade and amenity to the hard landscaping.



West Coast Highway, City Beach

The light pole and fence restrict the through-route to less than 1.0 m, presenting a major barrier for pedestrians with disability or prams



Hay Street, Perth

Colour can be used to assist pedestrians to notice the obstacles on the paths

Nb: feet on temporary barricade can be a trip hazard

7.2 Street Furniture

Objective

To outline design requirements and appropriate placement of street furniture such as seats, tables, bins, drinking fountains and telephones.

Key Points

Street furniture must not encroach on pedestrian path of travel.

7.2.1 Placement of Street Furniture

Ideally all street furniture should be placed in the Street Furniture Zone within the footpath cross-section so as to keep the pedestrian through-route free from obstruction. Street furniture includes fixtures such as trees, signposts, traffic signals and light poles, parking meters, rubbish bins, seats, tables, drinking fountains, planter boxes, telephones, advertising signs and vending machines.

The width of the Street Furniture Zone depends on the location of the footpath, the road function, and expected pedestrian demand and nearby pedestrian generators. This width can vary between 0.9 m - 1.2 m.

For shared paths, a minimum side clearance of 0.5m is required between the path edge and adjacent hazards (clearance of at least 1 m is preferred).

If placed away from the footpath the furniture must be connected with a hard surface and have sufficient circulation space for access.

When street furniture is located on the footpath then a clear path of travel of at least 1.2 m (preferably 1.5 m or wider) must be maintained along the building or property line. This will allow a navigational path for those with low vision, and allow a wheelchair to pass along the path. Signs placed along the edge of the pedestrian through-route should include protective edges to avoid injury.



Subi Centro



William Street, Perth

7.2.2 Colour

Street furniture should be designed with a significant colour contrast to the background and having a luminance factor of not less than 0.3 (30 percent) will be of considerable assistance to pedestrians with low vision.

Coloured borders in pavement details along the edge of street furniture may assist to highlight the location of furniture and the adjacent clear path of travel.



Subi Centro

7.2.3 Seating

Seating should be located off the path of travel, with at least 500 mm from the front of the seat to the pedestrian path.

No one size of seating will suit all people, however as a general rule the following design details will accommodate most adults.

Backrests are required to offer support and are best when the angle between the seat and the backrest is about 105 degrees.

Most seats are best set at approximately 450 mm above the ground. Ideally a variety of seat heights from 350 mm to 520 mm high will accommodate the needs of children through to seniors.

Armrests should be provided to assist in standing.

Provide clear space between the front legs of all seating to allow rear positioning of the feet when arising.

Seats should drain well and have no dangerous or sharp edges.



Subi Centro



Central Park, Perth

7.2.4 Bins

Most people can access bins when they are approximately 1000 mm high with the receptacle no further than 400 mm from the outer edge. Any lids must be carefully considered to allow access by those with limited mobility skills.



Subi Centro

7.2.5 Drinking Fountains

To accommodate the needs of most people drinking fountains at two different heights are preferable.

To ensure that one can be utilised by wheelchair users and children ensure there is knee and footplate space underneath and a push button or lever style control is fitted at the front of the unit.



Subiaco Train Station

7.2.6 Telephones

The Telstra public telephone designed for outdoors has features that suit most users. As these have side panels that do not extend to the ground they could create an overhead barrier so must be located well away from a path of travel.



Applecross

7.2.7 Street Trees and Vegetation

Overhanging bushes or trees can also act as a visual barrier or obstruction to a path. Local Government should regularly upkeep paths and act on hazard reports, to maintain the usability and safety of paths.

Hazard reports can be submitted by community members directly to the relevant local Council (check Local Government websites). Alternatively, hazards can be reported through the MRWA or Department of Transport's hazard reporting systems.

www.mainroads.wa.gov.au/OtherRoads/Pages/ReportProblem.aspx

www.transport.wa.gov.au/cycling/2345.asp



Vincent Street, Mt Lawley, example of well maintained landscaping

7.2.8 Bus Stop Shelter and Signs

The Public Transport Bus Stop Layout Guidelines provides guidance on the design and placement of bus stop infrastructure within a footpath. Examples are provided for a range of footpath and bus stop layout designs.

A continuous path with a desired width of 1.54 m should be maintained between the bus stop and the kerb, where insufficient space is available the absolute minimum width required is 1.2 m.

Rubbish bins should be located on the approach side of the shelter to maintain a continuous path. Warning TGSIs are to be placed before the rubbish bins if they are located in the pedestrian path of travel.

Directional TGSIs are to be used to lead to warning TGSIs which locate the position of the front door of the bus (in front of the bus stop sign). Refer to the TGSIs section (Section 8.3) for more information on TGSIs layouts at bus stops.



Source: Public Transport Bus Stop Layout Guidelines (PTA)

7.3 Grates / Covers

Objective

To illustrate the appropriate locations for and design of grates and covers in footpaths.

Key Points

Grates and covers should be flush with the adjacent path.

Gratings should be small enough to prevent canes and wheels from catching in the openings.

These are items such as manhole covers or drainage grates placed along the pedestrian path of travel.

Where covers are in the footpath they should be flush with the pavement and abutting the adjacent pavement material. Tolerances should not exceed 5mm.



Colin Street, West Perth

7.3.1 Grates

When grates are placed along a path of travel to provide drainage they must be flush with the adjacent ground surface and have gaps no greater than 150 mm long and 13 mm wide to prevent wheelchair castors and canes from becoming trapped. The longer gap is to run perpendicular to the direction of travel.

Where slotted openings are less than 8 mm, the length of the slots may continue across the width of paths of travel.



Subiaco Train Station

7.4 Vertical Clearances

Objective

To outline the requirements for vertical clearances for pedestrians.

Key Points

A minimum clearance of 2 m is required over a footpath (minimum 2.5 m over a shared path).

A minimum clearance of 2.5 m is required under traffic signs that overhang a shared path or footpath.

An adequate vertical clearance should be provided over the full width of the footpath, completely free of overhanging projections and obstructions. This includes overhanging vegetation as well as signs and low verandahs.



Station Street, Subiaco

A minimum height clearance of 2.0 m above the accessible path of travel is adopted by AS 1428.1 – 2009 (Clause 6.2, General Requirements for Access - Buildings).

However, it is preferable to have a greater vertical clearance than 2.0 m where possible. For example, some municipalities require trees overhanging footpaths to be trimmed to a clearance of 3.0 m. In addition, AS 1742.2 – 2009, Clause D2.3.5, outlines a minimum vertical clearance of 2.5 m for traffic signs located above footpaths.



William Street, Perth

7. Pedestrian Paths

For shared paths, the minimum vertical clearance is always 2.5 m above the path surface.

AS 1742.2 – 2009, Clause D.2.3.5, (Traffic Control Devices for General Use) recommends the following minimum height clearances below traffic signs where pedestrian are likely to be present:

- 2.0 m: Minimum clearance on kerbed roads in urban areas to prevent obstruction to occasional pedestrians
- 2.5 m: Minimum clearance under signs that overhang a shared path or footpath



William Street, Perth

In this example, the sign is 2.5 m above the footpath. Also, the sign has been mounted on a single post to minimise the obstruction of the posts.



Wellington Street, West Perth

The sign placed in the triangular island of the intersection in this example has a vertical clearance of only 1.7 m. The original sign had 2.5 m clearance but the hospital sign was added without consideration of pedestrians. The lower sign has now been relocated. The placement of the temporary roadworks sign also presents a potential hazard for pedestrians.



GNH/Roe Highway Intersection

7.5 Surfaces

Objective

To provide information on preferred pedestrian surfaces for footpaths and ramps.

Key Points

A firm stable surface is imperative. Concrete and bitumen surfaces are preferred.

Surfaces must be slip resistant, flat and even. Materials such as brushed concrete or asphalt are considered suitable. The texture of the surface shall be traversable by people who use a wheelchair and those with an ambulant or sensory disability.

Abutment of surfaces shall have a smooth transition. Design transition shall be 0 mm. Construction tolerances shall be as follows:

- (a) 0-3 mm vertical
- (b) 0-5 mm, provided the edges have a bevelled or rounded edge to reduce the likelihood of tripping

Any gaps, lips, joints or changes in height cannot exceed 5mm as these can create trip hazards. Asphalt surfacing can present the most suitable surfaces for all users as it eliminates joints where problems can occur. The use of 'lockjoint' at concrete path joins reduces the tripping hazard and damage from road sweepers cleaning a path.

Where footpaths are likely to be used for recreational running, asphalt footpaths are the preferred surface (information from the WA Marathon Club and Masters Athletics).

Note: The top photo illustrates the potential trip hazards at the joints along the concrete path surface.

The second photo illustrates a smooth path surface which removes trip hazards for pedestrians with wheelchairs or mobility scooters, as well as those with walking difficulties.



South Perth Foreshore



Stubbs Terrace, Shenton Park

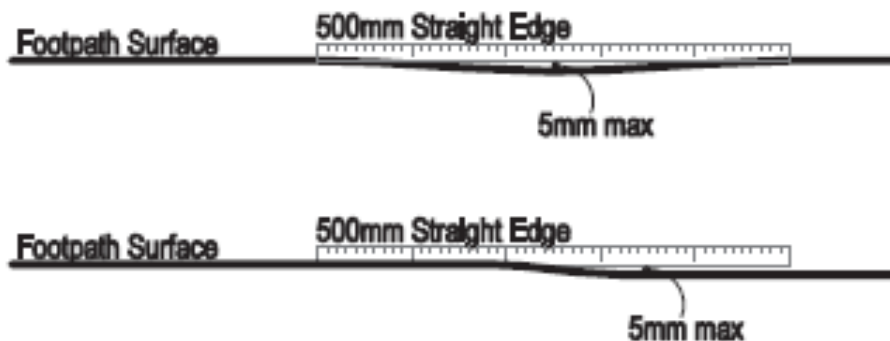

Measuring the maximum deviation of the surface

Source: Pedestrian Planning and Design Guide, NZ Transport Agency, (2009)

7.5.1 Paved Path Surfaces

Paved, textured surfaces should be slip resistant and designed to minimise tripping hazards and vibration for pedestrians. For continuous paving units, the maximum design height variation between pavers should be 2 mm. Construction tolerance allows for an occasional maximum height difference between pavers up to 5 mm (not as the design target).

The use of older style cobblestones should be avoided where possible, as these present particular hazards due to the uneven surface. Vibration can make it difficult for pedestrians with disability to control wheelchairs or scooters, particularly people using chin or alternative controls.



Uneven paved surface in Federation Square, Melbourne

7.5.2 Crossfall and Camber

Crossfall (or camber) is the slope of the footpath at right angles to the direction of travel. Some crossfall is required for drainage, but excessive crossfall results in difficult conditions for pedestrians with wheelchairs or walking frames, who have to exert extra energy to resist the sideways forces.

Crossfall in the through-route zone should not exceed 1:40 (2.5 percent); a flatter crossfall (1percent) is preferred, provided that the surface is adequately drained to avoid any ponding of water within the path. If necessary, steeper crossfalls can be created in the Street Furniture and/or Frontage Zone (see diagram in the right hand column).

For footpaths with asphalt bitumen surfaces, the maximum crossfall is 1:33 (3 percent).

Crossfalls are not required for footpaths (and ramps) with a gradient steeper than 1:33.

Note: The adjacent photo illustrates use of a retaining wall to provide a flat camber.



Subi Centro

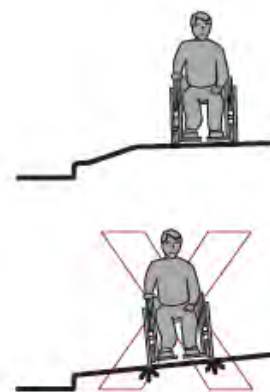

Correct and incorrect provision of crossfall
Source: Pedestrian Planning and Design Guide, NZ Transport Agency, (2009)

7.5.3 Drainage

Footpath surfaces must be designed to ensure adequate drainage as ponding or pooling of water can cause issues for people walking. Adequate drainage may be achieved by the use of effective camber and crossfall design and drainage gates if necessary.



Irwin Street, Perth

7.6 Gradients and Ramps

Objective

To provide information on acceptable gradients and design details for footpaths and ramps.

Key Points

Slope requirements for paths and ramps must be adhered to.

Handrails are required on both sides of ramps.

Landings must be provided as resting points on ramps.

Any change of direction requires a landing.

Edges must be safe with horizontal ground on either side, or kerbs.

7.6.1 Footpath Definition

A footpath (or walkway) is any pedestrian accessway with a gradient no steeper than 1:20.



Westralia Square, Perth

7.6.2 Ramp Definition

A ramp is an inclined accessway that has a constant gradient anywhere between 1:14 and 1:20. They provide a continuous accessible path of travel for pedestrians with mobility impairments and for other wheeled pedestrians (prams, scooters etc). Steeper gradients than 1:14 present problems of endurance for ambulant pedestrians and manual wheelchair users. They can also cause instability and loss of control for users of wheeled mobility aids.

Some people, especially those with a walking aid find ramps difficult to negotiate and may prefer a set of steps.

Due to natural topography some footpaths and shared paths are located on steep hills with gradients greater than 1:14. Efforts must be made to decrease these gradients especially in higher pedestrian areas. If it is technically not possible, building in landings at close intervals that act as resting points, providing handrails for support and / or some form overhead protection against inclement weather may assist.



Pedestrian Overpass, Kwinana Freeway and Preston Street, Como



Esplanade Train Station, Perth

7.6.3 Length of Ramps

Long straight ramps are not recommended for wheelchair users as it is possible for them to lose control down a long steep slope. Wet slippery surfaces can increase this risk. Providing regular landings or changes of directions on long ramps will break this build up of momentum, or alternatively overhead covering to prevent slipping may assist.



Roe Street, Northbridge, Pedestrian Overpass

7.6.4 Width

This will be dependent on the amount of pedestrian traffic to be accommodated on any path. The recommended minimum width of footpath and ramp is 1.5 m.

Note: This photo illustrates consideration to provide a ramp and a footpath of sufficient width within a restricted space. Note TGSIs are not provided at this site.



Station Street, Subiaco

7.6.5 Ramp and Footpath Landings

Landings provide an opportunity for pedestrians to rest and a flat surface for wheelchairs to change direction.

Ramp

A ramp with a gradient of 1:14 requires landings at least every 9 m.

A ramp with a gradient of 1:20 requires landings at least every 15 m.

Gradients in between require calculation of intervals by linear interpolation.



Pedestrian Overpass, Kwinana Freeway and Preston Street, Como

Footpaths

Footpaths with a gradient of 1:20 require landings every 15 m.

Footpaths with a gradient of 1:33 require landings every 25 m.

Footpaths that are flatter than 1:33 do not require landings.

Gradients in between require calculation of intervals by linear interpolation.

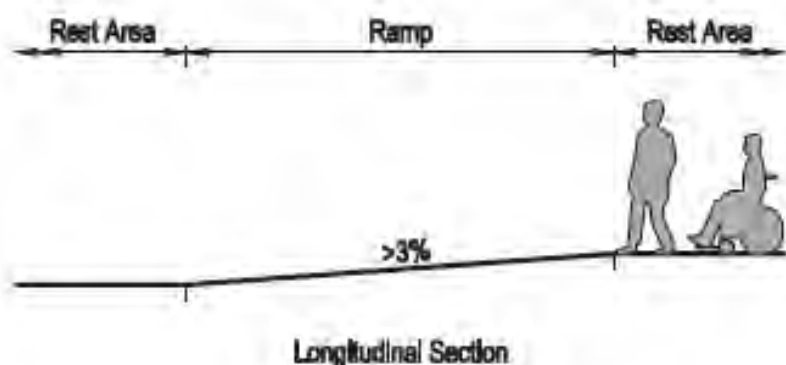

Rest areas in ramp

Source: Pedestrian Planning and Design Guide, NZ Transport Agency, (2009)

7.6.6 Landing Dimensions

The minimum dimensions that will enable most wheelchair users to rest or change direction as specified in AS1428.1 – 2009 Clause 10 are:

- 1200 mm long for a straight ramp
- 1500 mm long for a 90 degree turn
- 1540 mm wide by 2070 mm long, assuming two 1000 mm wide parallel paths with a 70 mm gap in between, for a 180 degree turn



Shenton Park Train Station

7.6.7 Handrail Positions on Ramps

Ramps require handrails on both sides. These are to be positioned at 865 mm to 1000 mm above the surface of the ramp, are not to encroach into required circulation spaces and extended 300 mm past the end of the ramp. For areas where there are expected to be a high percentage of children, a second rail should be positioned at 700 mm above the surface of the ramp.



Pedestrian Overpass, Kwinana Freeway and Preston Street, Como

7.6.8 Handrail Details

These should be circular or elliptical (with the horizontal dimension larger than the vertical dimension) with a diameter of 30 mm - 50 mm to allow a reasonable grasp by most hands.

The top of the handrail is to be free for the hand to slide along the top 270 degrees without being hindered. This means that wall fittings will generally need to be attached to the underside of the rail.

Clearance between the handrail and any adjacent wall is to be at least 50 mm and this clearance is to extend above the top of the handrail by not less than 600 mm.



Pedestrian Overpass, Kwinana Freeway and Preston Street, Como

Ends of the handrails should ideally continue in the horizontal plane of the ramp for 300 mm without encroaching in the circulation space at either the top or bottom of the ramp. This allows a person to steady themselves through the changes of level and provides a cue for a person with vision impairment.

Ends need to be turned under for 180 degrees or returned to the wall.

Colour contrast these handrails against the background surface.

7.6.9 Edge Treatments

If there is no wall or balustrade, or the ground on either side of the ramp or footpath does not continue for at least 600 mm (i.e. ground drops away), then kerbs must be installed for the safety of all pedestrians. These are required to be flush with the inside of the handrail and a minimum height of 65 mm with the top edge not terminating between 75 mm and 150 mm high, or have gaps within this region. This is to prevent wheelchair footplates becoming jammed.



Pedestrian Overpass, Kwinana Freeway and Preston Street, Como

7.6.10 Warning Tactile Ground Surface Indicators (TGSI)

AS/NZS1428.4.1 – 2009 specifies that warning TGSI are required at the top and bottom of ramps. The MRWA policy does not include this requirement.

They are not required on landings where the handrail continues through the landing. Refer to Section 8.3 and AS/NZS 1428.4.1 – 2009 for more information on TGSI.



Claisebrook Train Station

7.7 Steps and Stairs

Objective

To illustrate design requirements for steps and stairs.

Key Points

- Stairs are not to be the only means of vertical access.
- Geometry to be even and constant throughout the stairway.
- Risers must be closed.
- Handrails are required on both sides.
- Provide colour-contrasting nosings.
- Install warning TGSi at the top and bottom of a stairway.

Steps and stairs must not be the only access between two levels. Ramps and / or lifts will be required by those with a mobility restriction who cannot use stairs.

Note: This photo illustrates the provision of both steps and a ramp in close proximity. No TGSi or stair nosings have been provided for these facilities.



**Underpass at
Princess Margaret Hospital**

7.7.1 Geometry

Treads and risers must be uniform throughout the entire stairway.

Stairways should be constructed with closed risers as open risers can be a trip hazard and visually disconcerting. Spiral stairways are not to be provided.

The tread should not overhang the riser more than 25 mm.

It is recommended that the tread is to be at least 300 mm and risers to be 150 - 165 mm. A 100 mm step height may be more appropriate for the elderly and disabled.



Shenton Park Train Station

Stairs require handrails on both sides. These are to be positioned at 860 mm to 1000 mm above the tread of each step. For areas where there are expected to be a high percentage of children, a second rail should be positioned at 700 mm above the surface of the ramp.

Warning style TGSIs are to be installed at the top and bottom of all stairs.

Refer to AS/NZS 1428.4.1 – 2009 for more information on TGSIs.

7.7.2 Nosing

Slip resistant colour contrast nosings to be applied to the tread on every step.



Westralia Square, Perth

7.7.3 Handrail Details

Handrails for stairs follow the same requirements as for ramps outlined in the previous section.



Shenton Park Train Station

7.8 Crossovers / Driveways

Objective

To illustrate the important issues when extending footpaths across driveways and to ensure barriers are not created for pedestrians.

Key Points

Design details for a footpath must be maintained throughout the crossover.

Generally paths should continue through crossovers, providing a clear visual cue of pedestrian priority across driveways.

The crossover should be as flat as possible throughout the width of the footpath. Crossfall must not be greater than 1:40.

If the full width of the footpath cannot be constructed to footpath design details, then a minimum of 1.2 m must be flat, preferably adjacent to the building line.

Truncation at the building line is required to provide adequate visibility between pedestrians and drivers.



West Coast Highway, Scarborough
Path continues across the driveway
(vehicles give way to pedestrians)

7.8.1 Warning TGSI

Warning style TGSI are generally not required at driveways unless the lines of sight of the drivers are restricted or if the driveway is considered to be particularly busy or dangerous.

Refer to Section 8.3 and AS/NZS 1428.4.1 for more information on TGSI.

Note: In the adjacent photo the driveway is designed as an intersection, whereby pedestrians give way to vehicles (including TGSI to warn pedestrians of the conflict area). The driveway forms an entrance to a major car parking facility and due to the volume of vehicle movements was considered too dangerous to design as a standard vehicle crossing. The impact on pedestrian access and safety should be considered before giving priority to motorists through.



Hospital Avenue, Nedlands
Example of a driveway serving large car park
designed as an intersection (pedestrians give
way to vehicles).

7.9 Barricades (including chicanes and bollards)

Objective

To demonstrate suitable materials for fencing and boundaries and appropriate designs for barricades to ensure they will not become barriers for pedestrians.

Key Points

Boundaries to paths such as fences and landscaping are appropriate.

Chicanes and mazes must be visible and provide sufficient circulation space to allow wheelchairs and other users to pass through.

Temporary barricades must be visible and have warning signs in appropriate positions.

Walls, weld-mesh fences and landscaping are suitable edges for footpaths.

Pedestrian bridges and elevated ramps require balustrades.

Balustrades should not interfere with sight lines on winding ramps. On coming pedestrians or cyclists should be visible.

Chicanes, mazes, bollards and temporary barricades require special consideration for people with disability and other users.

Hedges or plantings must be well maintained and kept at a height that does not impinge on lines of sight.



Roberts Road, Subiaco

7.9.1 Chicanes and Mazes

These present particular hazards to pedestrians who have visual impairment as a high rail will not be detected by a cane and as they are oriented across the path of travel may be difficult to see. To enable a chicane or maze to be detected by a cane, the rail should be no higher than 0.25 m.

The path of travel through the maze must be of sufficient width to allow access by a wheelchair. A width of at least 1.5 m in the direction of approach and through the rails is recommended.

Note: This bridge in the adjacent photo forms part of the Perth CBD shared path network and the chicanes are used to reduce cyclists and pedestrian conflict, but they are not a desirable treatment due to the hazards for all wheeled users.



Pedestrian Overpass, Roe Street, Northbridge

7.9.2 Temporary Barricades

Temporary barricades must be well signed at locations in the path where a pedestrian can make a decision to cross. This will prevent pedestrians reliant on kerb ramps from having to turn back to cross the road. Sometimes there is insufficient space for a wheelchair to turn 360 degrees.

For pedestrians who are blind a barricade that does not extend to at least 0.25 m above the ground, will not be detected by a cane and could cause an injury. Ropes or chains supported by poles are not suitable temporary barricades.

Note: Top photo illustrates inappropriate barricade.



Cook Street, Subiaco



St Georges Terrace, Perth



Murray Street, Perth

8. Pedestrian Crossing Elements

In this Section

- 8.1 Kerb Crossing Ramps and Pedestrian Cut-Throughs
 - 8.1.1 Alignment and Surface of Kerb Ramps
 - 8.1.2 Gradient and Length of Kerb Ramps
 - 8.1.3 Camber of Kerb Ramps
 - 8.1.4 Landings at Kerb Ramps
 - 8.1.5 Type A Kerb Ramp
 - 8.1.6 Type B Kerb Ramp
 - 8.1.7 Description of Pedestrian Cut-Throughs
 - 8.1.8 Alignment of Cut-Through
 - 8.1.9 Width of Pedestrian Cut-Throughs
 - 8.1.10 Transition of Cut-Throughs
- 8.2 Grab Rails
 - 8.2.1 Design
 - 8.2.2 Location
- 8.3 Tactile Ground Surface Indicators
 - 8.3.1 Consultation with User Groups
 - 8.3.2 Types of TGSi
 - 8.3.3 Warning TGSi
 - 8.3.4 Warning TGSi Applications
 - 8.3.5 Directional TGSi
 - 8.3.6 TGSi at Kerb Ramps
 - 8.3.7 TGSi at Bus Stops
 - 8.3.8 TGSi at Cut-Throughs
- 8.4 Audible/Tactile Pedestrian Signals
 - 8.4.1 Usage
 - 8.4.2 Position of Push Button Assembly
 - 8.4.3 Push Button Orientation
 - 8.4.4 Push Button Orientation for Exclusive Pedestrian Phases
 - 8.4.5 Push Button Orientation for Parallel Pedestrian Phases
 - 8.4.6 Circulation Space

8.1 Kerb Crossing Ramps and Pedestrian Cut-Throughs

Objective

To outline the requirements for designing kerb ramps and pedestrian cut-throughs so that they can be easily negotiated by all pedestrians.

Key Points

The surface must be firm and stable.

The correct relationship between length and gradient of kerb ramps is essential.

Corresponding kerb ramps must be correctly aligned and perpendicular to the direction of travel.

Flat landings must be located at the top and bottom of kerb ramps.

Pedestrian cut-throughs provide a clear continuous path of travel for wheelchair users.

Kerb ramps link footpaths across a roadway. A kerb ramp provides a continuous path of travel for pedestrians with mobility impairments or wheeled devices, such as wheelchairs and prams. Kerb ramps also assist with defining the preferred crossing location for all pedestrians.

A number of different configurations for kerb ramps and landings are provided in AS1428.1 – 2009 Section 10. For information on Tactile Guidance Surface Indicators (TGSIs), refer to the following section (Section 8.3) and AS/NZS 1428.4.1 – 2009 (Appendix C in particular).



Preston Street, South Perth

8.1.1 Alignment and Surface of Kerb Ramps

Kerb ramps are imperative in providing a continuous path of travel for pedestrians. This continuous pedestrian network is only provided when corresponding kerb ramps are provided on either side of a road and are aligned with each other.

Ramps are to be located perpendicular to the direction of travel. Avoid locating kerb ramps on the apex of a corner that will lead pedestrians into the middle of an intersection.

Some colour contrast is useful to assist in identifying the adjacent kerb ramp. Brushed concrete provides the most suitable surface for a kerb ramp. This material provides a firm, even, stable and slip resistant surface.



Hamersley Road, Subiaco

8.1.2 Gradient and Length of Kerb Ramps

The maximum kerb ramp gradient is 1:8, as specified in AS1428.1 – 2009. However the more desirable gradient is 1:10 or less, as per the MRWA and Austroads guidelines. The length of the ramp is not to exceed 1.52 m. These details are important as significant effort is required for manual wheelchair users to self propel up steeper gradients and this effort can only be maintained for short distances.

Consistency of the gradient throughout the entire ramp is important. This means that both sides of the ramp must be the same length. Sharp transitions must be provided between the planes of landings and ramps.



8.1.3 Camber of Kerb Ramps

Reducing the cross slope is important as gradients of 1:10 with a camber or crossfall will create significant barriers for pedestrians who rely on wheeled mobility aids. The uneven surface presented by poorly designed camber can lead to pedestrians falling out of wheelchairs or mobility scooters. As well as potentially receiving a serious injury from the fall, pedestrians are at risk of even greater injury from passing motorists if they are tipped onto the road.

Note: The top photo illustrates a kerb ramp with an unacceptable camber. The TGSi and ramp are sloped at a right angle to the crossing, creating an uneven platform for a wheeled mobility scooter.

The design below illustrates how this problem can be rectified. The ramp does not have a cross-slope at right angles to the direction of travel, with an acceptable gradient leading down to the road edge.



Incorrect Camber: Corner of Aberdare Road and Railway Parade, Nedlands



Correct Camber: Corner of Belmont Avenue and Great Eastern Highway, Belmont

8.1.4 Landings at Kerb Ramps

Landings must be provided at all changes in direction.

Level landings no steeper than 1:40 and no shorter than 1.5 m must be provided at the top of every kerb ramp. This allows wheelchair users to change their direction of travel on a level surface whilst maintaining stability.

If a change in direction is not required, the length of the landing can be a minimum of 1.2 m.

Where there is insufficient space at the top of a kerb ramp, it may be possible to grade the footpath to provide flush access to the roadway. An island is retained on the apex of the corner. Warning style TGSIs are required at each crossing point, set back from the road edge.

For detailed drawings and measurements refer to AS1428.1-2009-Design for Access and Mobility Part 1 (Figure 24A) and AS/NZS1428.4.1-2009-Design Criteria for Kerb Ramps (Figure C1)



Stubbs Terrace, Shenton Park



8.1.5 Type A Kerb Ramp

MRWA Type A kerb ramp is the standard used for paths located within a road verge. The shoulders are designed to minimize the trip hazard for pedestrians walking parallel to the ramp.

Refer to MRWA Standard Drawing 9831-5649 for ramp layout, and 200931-0089 for tactile layout.

Note: the maximum ramp gradient specified in the MRWA standard is 1:10, less than the 1:8 absolute maximum gradient specified in AS1428.1 – 2009.

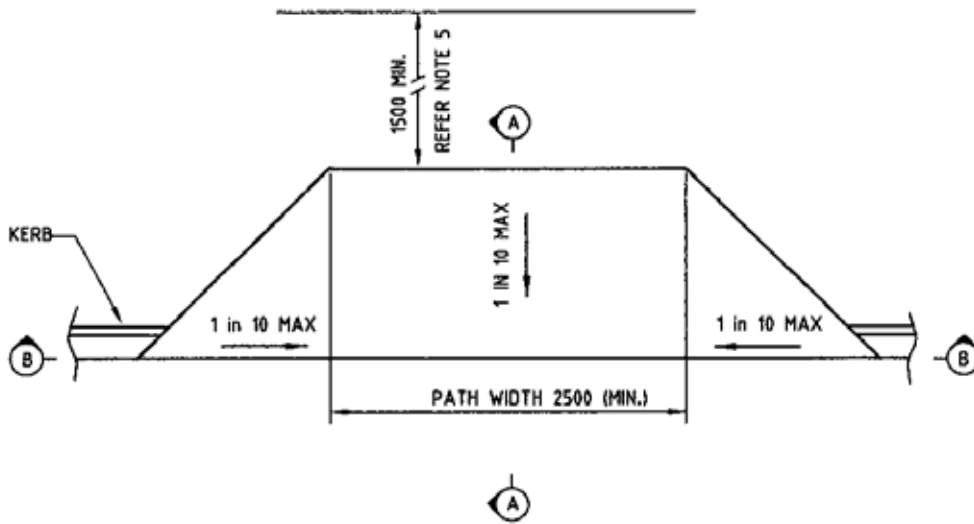

PLAN - KERB RAMP - TYPE A
 ROAD VERGE LOCATION
 NO GRAB RAIL

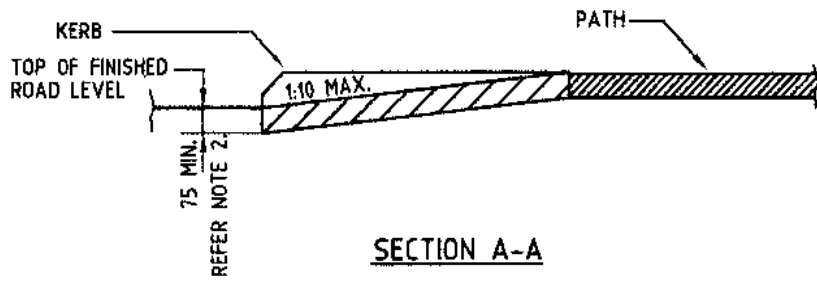

SECTION A-A

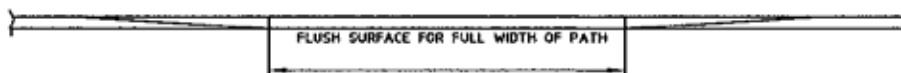

SECTION B-B

MRWA Standard Drawing 9831-5649

8.1.6 Type B Kerb Ramp

MRWA Type B kerb ramp is used where the pedestrian traffic flow is on the path and kerb ramp only; i.e. at a median or median island location. In this case, the ramp is constructed up to the edge of the median kerb (no ramp shoulders).

Refer to MRWA Standard Drawing 9831-5649, and 200931-0089 for tactile layout.

Note: the maximum ramp gradient specified in the MRWA standard is 1:10, less than the 1:8 absolute maximum gradient specified in AS1428.1 – 2009.

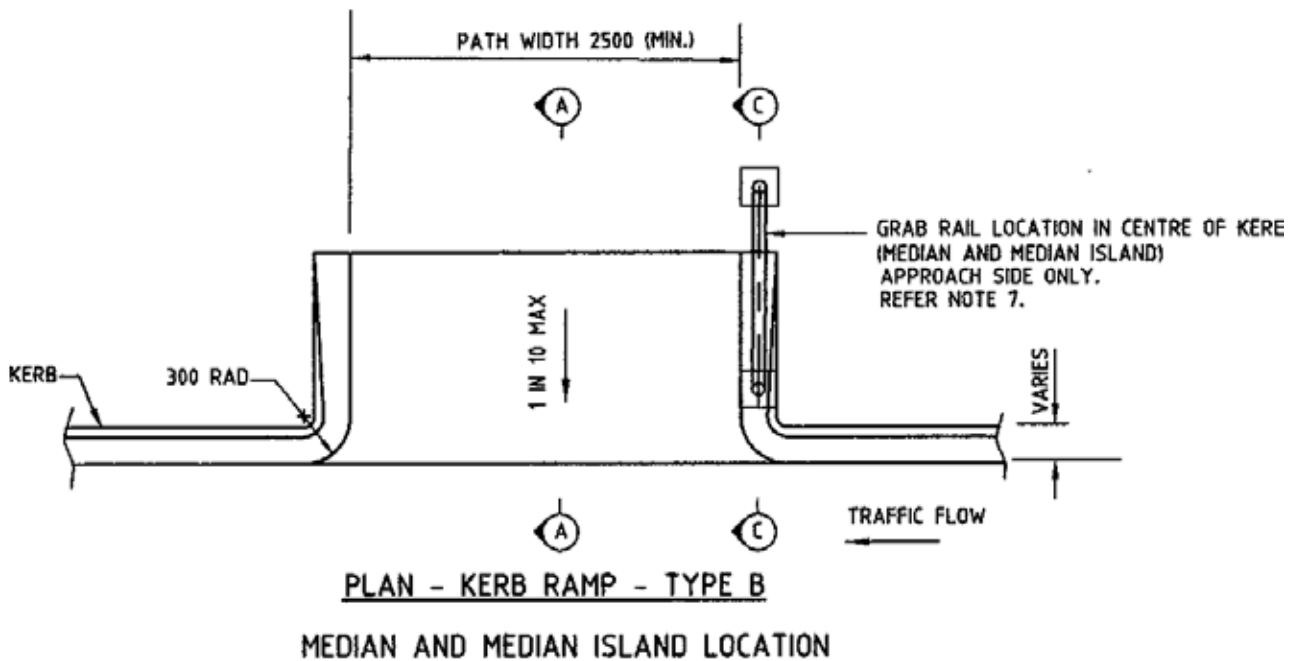

MRWA Standard Drawing 9831-5649

8.1.7 Description of Pedestrian Cut-Throughs

Where the designated pedestrian footpath across a roadway includes sections across raised median strips or splitter islands, cut-throughs are required.

As a guide, where the island width is less than 4.5 m, a cut-through is the preferred crossing treatment (in place of kerb ramps on either side of the island). This provides level access across the entire pedestrian crossing with only two ramps, one to enter the crossing and the other to exit it.



Stubbs Terrace, Shenton Park

8.1.8 Alignment of Cut-Through

The cut-through should be aligned parallel to the direction of pedestrian flow.

Note: in the adjacent photo the TGSIs do not provide adequate contrast with the adjacent path surface



Intersection of William Street and Riverside Drive, Perth

8.1.9 Width of Pedestrian Cut-Throughs

The cut-through should extend across the entire width of the pedestrian crossing.

The minimum cut-through width is typically 2.5 m.

A minimum length of 1.8 m across a traffic island or median is required, to allow a person with a pram, mobility scooter or bicycle to safely wait in the cut-through.

More detail on the design of pedestrian refuges and cut-throughs is provided in Section 9.3.

Note: in the adjacent photo there is debris which is a potential trip hazard – highlighting the importance of regular maintenance programs for all pedestrian facilities.



Intersection of Railway Road and Aberdare Road, Karrakatta

8.1.10 Transition of Cut-Throughs

Transition from kerb ramps or cut-throughs to the road must be flush, ie no lip or gap.

Where there is a camber in the road surface the angle between the road and the ramp must not be less than 166 degrees.

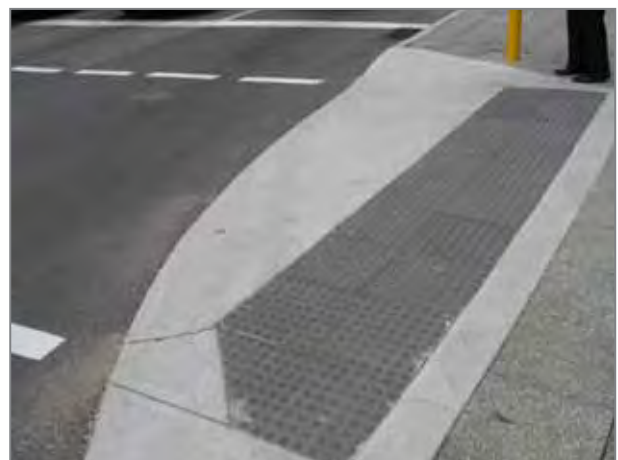

Riverside Drive, Perth

8.2 Grab Rails

Objective

To demonstrate the design, colour and location of useable grab rails.

Key Points

Locate on the left hand side of the pedestrian path.

Provide good colour contrast to the adjacent environment.

An upside down U shaped rail to provide support for cyclists and pedestrians, primarily used at kerb ramps and cut-throughs. Grab rails also act as an additional warning cue to motorists, about the potential presence of pedestrian and cyclists crossing the roadway.

MRWA Standard Drawing 9831-5649 provides design details for grab rails.



Bourke Street, Leederville

8.2.1 Design

The top of the grab rail is to be 0.865 m – 1 m above the ground and is intended for stability. MRWA specifies a 0.9 m height above the ground level.

In order to detect grab rails and to assist in location of kerb ramps provide a good colour contrast to the adjacent surface or local environment. MRWA Standard Drawing 9831-5649 provides details on the paint and reflective tape colours and requirements.



Churchill Street, Subiaco

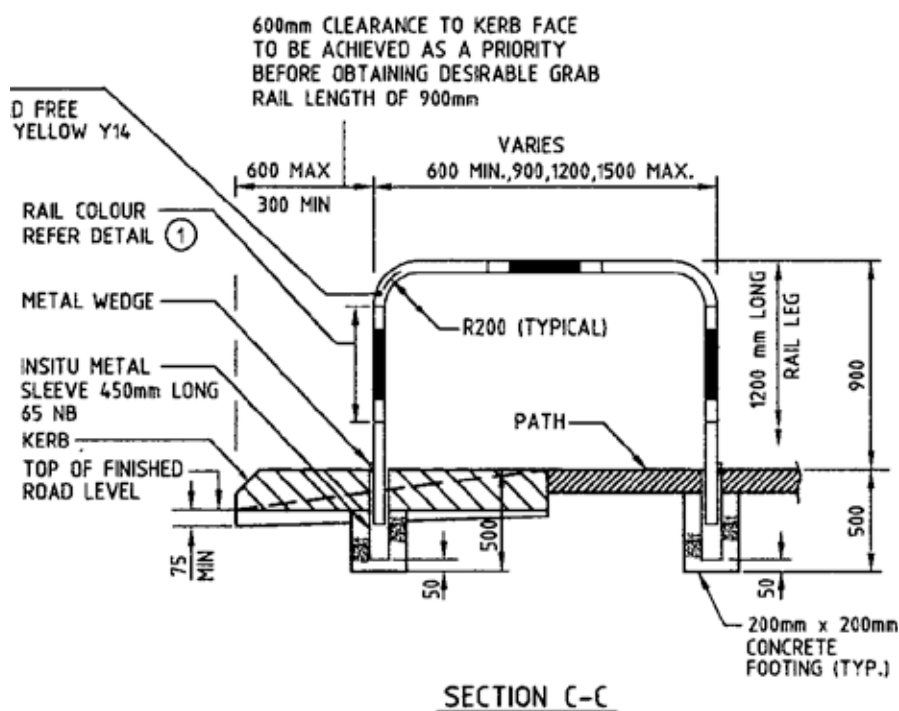

MRWA Standard Drawing 9831-5649

8.2.2 Location

Locate grab rails at the top of a kerb ramp and on the side approaching the roadway, parallel to the direction of travel. There is some debate as to whether the grab rail should be installed on the left side rather than the traffic approach side (since these do not always coincide), as some consider the grab rail to be more useful on the left side. For wide medians one grab rail should be placed beside the ramp on either side of the cut-through or refuge.

Grab rails should not encroach on the path of travel.

The grab rail is to be setback a minimum clearance of 0.3 m from the kerb edge, a maximum distance of 0.6 m.



West Coast Highway, City Beach

MRWA Standard Drawing 9831-5649 provides the following recommendations for the placement of grab rails in medians:

- A median <1.2 m wide – no grab rail
- A median 1.2 m to 2.0 m wide – 0.6 m long grab rail
- A median >2.0 m – 0.9 m long grab rail

At signalized intersections grab rails should be omitted if they encroach on the circulation space directly in front of the push button assembly.

The inclusion of a grab rail in all crossings within medians wider than 1.2 m is not always necessary. Consideration should be given to the volume of pedestrians and cyclists crossing and whether the grab rail would provide a safety benefit by highlighting the crossing location to motorists.

8.3 Tactile Ground Surface Indicators (TGSI)

Objective

To identify the different types of tactile ground surface indicators and demonstrate how and where they should be applied.

Key Points

Provide physical cues in the absence of alternative existing cues.

The two types are WARNING and DIRECTIONAL.

WARNING used to identify hazards and targets.

DIRECTIONAL used to identify a safe path of travel.

People who are blind or have low vision rely on audible, physical and tactile cues to help them move independently and safely through the pedestrian environment. Typical cues include the kerb edge and building line edge to safely guide pedestrians along a footpath.

TGSI are, in essence, one form of physical or tactile cue. They are used in situations where there are not enough existing cues available at a given site and are applied on the ground within the path of travel. In the absence of other cues they are used to guide pedestrians to change direction (to access a bus stop, building), or to warn of an upcoming pedestrian hazard (roadway, steps).

AS/NZS1428.4.1 – 2009 provides design standards in regards to the application of TGSI. While the standards primarily refer to ‘new building work’, they should also be considered for all pedestrian access routes and used in busy pedestrian areas and sites where people with a disability are likely to be walking. A designer or engineer should incorporate appropriate TGSI where necessary to ensure adequate safety and orientation.



Subiaco Train Station



Subiaco Train Station

It is understood that TGSi treatments can cause difficulty for other pedestrian groups particularly those using wheelchairs and other walking aids. TGSi should only be used where necessary and applied in a manner that minimises any inconvenience to other pedestrians. If eliminating the use of TGSi, consideration must be given to the requirements of the Disability Discrimination Act (Section 23 in particular) which takes primacy over Australian Standards. Sensitive design can reduce or eliminate the need for TGSi treatments. The application of TGSi will not correct bad design or make an unsafe environment safe. Good design will minimise the need for the use of TGSi.

A useful summary of common issues when installing TGSi and other facilities for people with disability was produced by the Human Rights Commission: www.hreoc.gov.au/disability_rights/buildings/good.htm



Roberts Road, Subiaco

Note: The bottom picture illustrates how designing in a detectable landmark, in this case the corner of the low fence, can negate the need for TGSi.

8.3.1 Consultation with User Groups

Early consultation with user groups (such as Association for the Blind or Blind Citizens WA) is recommended, especially where design options are limited. Consultation will assist in taking into considerations the needs of the users in the design process.



8.3.2 Types of TGSIs

There are two types of TGSIs, namely, warning and directional. Warning TGSIs, which look like a series of raised dots or plateaus, are used to warn of a hazard or target. Directional TGSIs, which look like a series of raised bars, are used to indicate the presence and direction of a safe path of travel.



Warning Style TGSIs



Directional Style TGSIs

8.3.3 Warning TGSIs

Warning TGSIs should:

- Have a profile that complies with AS/ NZS1428.4.1 – 2009
- Be positioned 0.3 m away from the hazard or target
- Extend across the entire width of the walkway
- Be a minimum of 0.6 m to 0.8 m deep
- Be colour contrasted against the surrounding pavement
- Be set perpendicular to the direction of travel or approach



Bagot Road, Subiaco

8.3.4 Warning TGSi Applications

They are required at:

- AS/NZS1428.4.1 – 2009 requires TGSi at the top and bottom of stairs, ramps, escalators and lifts
- Kerb ramps
- Pedestrian cut-throughs
- Flush kerbs
- Overhead obstructions
- The edge of railway platforms, marine wharf's or water bodies
- Change of direction in a directional TGSi treatment
- At approach to bus stop seats, shelter and other discretionary infrastructure which narrow the continuous path at public transport stops/stations
- At the end of the directional TGSi which lead to the location of the front door of the bus (in front of the bus stop sign)



St Georges Terrace, Perth



Subiaco Train Station

8.3.5 Directional TGSIs

Directional TGSIs should:

- Have a profile that complies with AS/ NZS1428.4.1 – 2009
- Be colour contrasted against surrounding pavement

Directional TGSIs treatments indicate a safe path of travel in the direction of the raised bars and are generally used in two different circumstances:

1. Across a path of travel to identify the point at which a pedestrian needs to turn to access a particular target such as a mid block pedestrian crossing, bus stop or point of entry to a significant public facility, e.g., railway station, public hospital or community health centre. In these situations the directional TGSIs treatments should also:

- Be set perpendicular to the flow of pedestrian traffic
- Be 0.8 m deep
- Extend across the entire width of the walkway
- Be aligned to the left hand side of the adjoining pathway

2. As a dedicated guidance strip to identify a safe path of travel through an otherwise complicated site, with few or no alternative cues, such as large open pedestrian plazas. For these types of applications it is assumed that the start and end points of the strip can be appropriately identified. The purpose of the guidance strip is simply to provide a tactile cue from point A to point B. In these situations the directional TGSIs treatments should also:

- Be 0.3 m to 0.4 m wide
- Be laid along the midline of the safe path of travel
- Allow for minimum clearance on both sides of at least 0.6 m



Hay Street, Subiaco



West Coast Highway, Floreat



Westralia Square, Perth

Note: Bottom photo shows inadequate TGI luminance contrast.

8.3.6 TGSi at Kerb Ramps

Warning style TGSi are required in kerb ramps directing pedestrians onto busy or hazardous streets. Refer to MRWA standard drawing 200931-0089 and AS/NZS1428.4.1 – 2009 (particularly Appendix C) for more information on TGSi arrangements at kerb ramps.

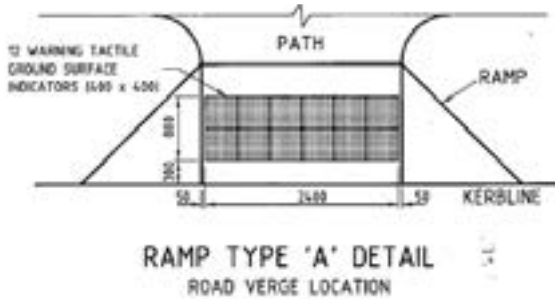

MRWA Standard Drawing 200931-0089



West Coast Highway, City Beach

8.3.7 TGSi at Bus Stops

The Public Transport Bus Stop Layout Guidelines (PTA) specifies for directional and warning TGSi to be installed at all new bus stops to guide pedestrians to and from the bus entry point. The TGSi layout should always comply with AS/NZS1428.4.1 – 2009.

The Public Transport Bus Stop Layout Guidelines provides example layouts for a range of bus stop designs. The standard layout for TGSi along train platforms is outlined in the PTA Station Design Guidelines,

Examples of bus stop and train station TGSi layouts are also provided in AS1428.1 – 2009 Appendix D. Where a bus stop is not located in the pedestrian path of travel, 2 rows of directional TGSi are to be placed across the full width of the footpath. Outside of the continuous footpath width, a single row of directional TGSi is to be installed to guide the pedestrian to the bus entry point, defined by 2 rows of warning TGSi.

The directional TGSi will intercept all pedestrians and guide them to the bus entry point. Likewise, when exiting a bus, the directional TGSi will guide a pedestrian to the accessible path of travel along a footpath.

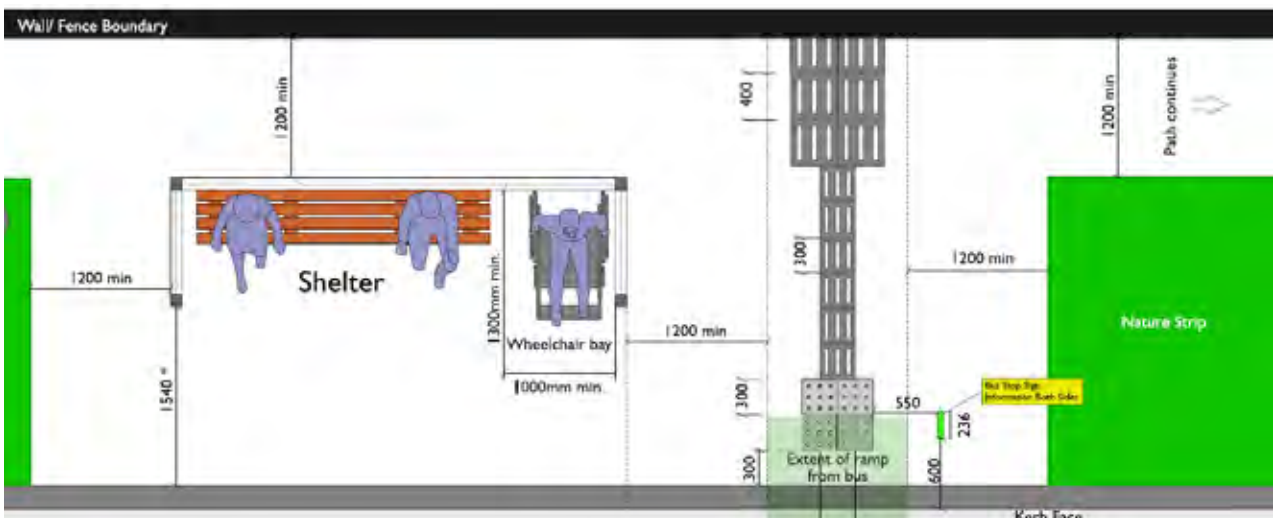

Source: Public Transport Bus Stop Layout Guidelines (PTA)

8.3.8 TGSIs at Cut-Throughs

Depending on the length of the cut-through, warning TGSIs are applied either at the centre of the cut-through or, at the entry and exit of the cut-through to identify the road edge.

MRWA Standard Drawings 200931-0090 and 200931-0091 provide details on kerb ramp and TGSIs layout at medians and islands with pedestrian cut-throughs.

MRWA Standard Drawing 200931-0091 specifies for 2 rows of TGSIs to be located in the centre of a cut-through if the median width is 2.9 m or less.



Stubbs Terrace, Shenton Park

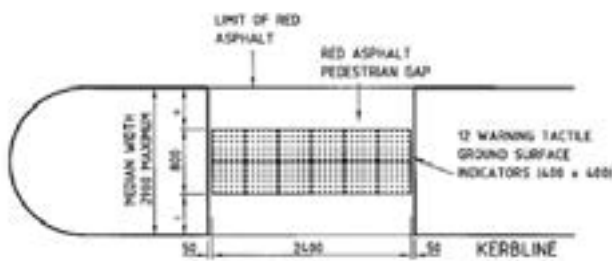

MRWA Standard Drawing 200931-0091 specifies for 2 rows of TGSIs to be located at each end of a cut-through if the median width is greater than 2.9 m.



Corner of William Street and Riverside Drive, Perth

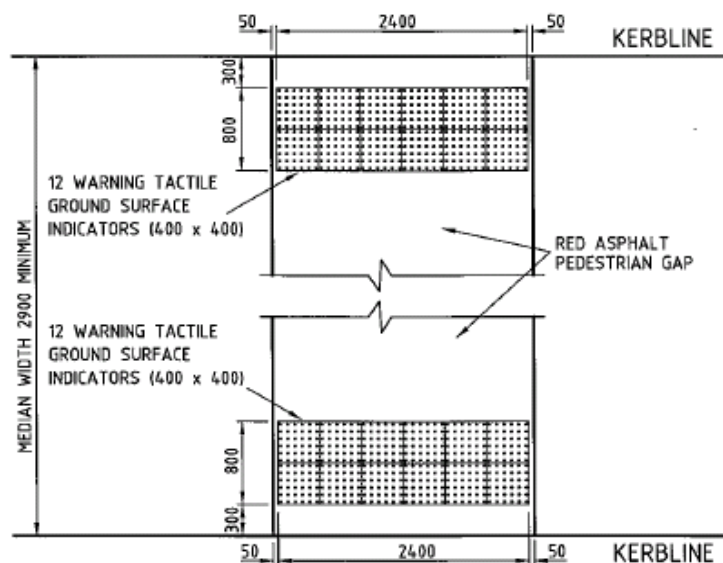

Also refer to AS/NZS 1428.4.1 – 2009 (particularly Appendix C) for more information on TGSIs layout in a range of situations.

8.4 Audio-Tactile Facilities

Objective

To highlight key design and layout requirements for the provision of audio-tactile facilities.

Key Points

To be installed wherever visual pedestrian signals are provided.

To be appropriately oriented to the pedestrian crossing.

To provide sufficient circulation space.

To be mounted at an appropriate height and to be reachable by all pedestrians waiting to cross.

Audio-tactile pedestrian signals provide audible and tactile cues that duplicate visual cues provided to pedestrians at signalised intersections. They are used by pedestrians with vision impairments, and other disability, to help identify which pedestrian crossing phase is active.

An audible tone and a tactile pulse are emitted at the push button assembly unit.

Audio-tactile pedestrian signals should be provided whenever visual pedestrian signals are installed. This includes both signalised traffic intersections and signalised dedicated pedestrian crossings.

MRWA Guideline for Pedestrian Signals (D08#6040) provides guidance on the inclusion of audible / tactile facilities. AS1742.14 – 1996 Clause 5.6 includes information on the placement of push-buttons.



Karrakatta Cemetery



**Corner of Station Street and Roberts Road,
Subiaco**

8.4.1 Usage

The audio-tactile push button assembly is usually mounted on the traffic signal pole. It should be reachable by a pedestrian waiting to cross.



Corner of Station Street and Roberts Road, Subiaco

8.4.2 Position of Push Button Assembly

Common reach range for ambulant pedestrians and wheelchair users is 0.9 m to 1.1 m. Ideally, the push button assembly should be mounted with a centre point height of 0.9 m above the adjoining pedestrian surface.

The push-button assembly should be located within 0.3 m of the pathway (and kerb crossing ramp with TGS), a maximum distance of 0.4 m.

If a traffic signal pole is located too far from the pedestrian pathway, a secondary pole for the push-button may need to be installed within reach distance of the kerb crossing ramp and TGS.



Shenton Park Train Station on Railway Road

8.4.3 Push Button Orientation

MRWA standard procedure for the positioning of push buttons at traffic signals is outlined in the Guideline for Pedestrian Signals (D08#6040).

There are two different orientation layouts for push buttons located at signalised crossings. The two different layouts enable pedestrians with visual impairments to identify the pedestrian crossing phase provided at each traffic signal.



Correct push button orientation for mid-block crossings and traffic signals with an exclusive pedestrian phases

8.4.4 Push Button Orientation for Exclusive Pedestrian Phases

For a midblock pedestrian crossing and signalised intersections with an exclusive pedestrian crossing phase, the push button assembly is mounted facing the oncoming pedestrian flow. Orientation of the arrows is up (meaning straight ahead). This is illustrated in the photo opposite.



Corner of Station Street and Roberts Road, Subiaco

Note: This push button assembly in the adjacent photo is mounted too high.

8.4.5 Push Button Orientation for Parallel Pedestrian Phases

At signalised intersections where pedestrians cross directly to the opposite side of the road (parallel pedestrian phases with partial or full protection from turning vehicles) the push button is mounted on the side of the signal pole, with the arrow pointing horizontally towards the direction of travel.

This is the same orientation used for push buttons located within a traffic island or cut-through at a traffic signal, illustrated in the photos opposite.



Corner of Aberdare Road and Railway Road, Karrakatta

8.4.6 Circulation Space

Ensure 180 degrees of flat, level obstruction free area immediately in front to allow wheelchair access.

Grab Rails

Locate grab rails at the top of a kerb ramp and to the left hand side as approaching the roadway, parallel to the direction of travel. These should not encroach on the path of travel.

At signalised intersections grab rails should be omitted if they encroach on the circulation space directly in front of the push button assembly.



Corner of Station Street and Roberts Road, Subiaco

9. Pedestrian Crossing Facilities

In this Section

- 9.1 Sight Lines
 - 9.1.1 Crossing Sight Distance
- 9.2 Warrants for Pedestrian Crossings
 - 9.2.1 MRWA Mid-block Crossing Warrants
 - 9.2.2 Warden Controlled Children's Crossing
 - 9.2.3 MRWA Left Turn Slip Lane Crossing Warrants
 - 9.2.4 WAPC Traffic Assessment Guidelines for Developments
 - 9.2.5 Queensland Transport and Main Roads Pedestrian Crossing Guideline
- 9.3 Mid-block Crossings
 - 9.3.1 Crossing Types – vehicle priority (pedestrians give way to oncoming vehicles):
 - 9.3.2 Raised Medians
 - 9.3.3 Painted Medians
 - 9.3.4 Pedestrian Refuge Islands
 - 9.3.5 Kerb Extensions (or Nibs)
 - 9.3.6 Zebra Crossings
 - 9.3.7 Wombat Crossings
 - 9.3.8 Mid-Block Signalised Crossings - Pelican Crossings
 - 9.3.9 Mid-Block Signalised Crossings - Puffin Crossings
 - 9.3.10 Warden Controlled Children's Crossings
- 9.4 Non-Signalised Intersection Crossings
- 9.5 Signalised Intersection Crossings
 - 9.5.1 Design Details
 - 9.5.2 Signal Displays
 - 9.5.3 Circular Signals
 - 9.5.4 Timings
 - 9.5.5 Staged Crossings
 - 9.5.6 Left Turn Slip Lanes
 - 9.5.7 Parallel Pedestrian Crossings - No Protection by Vehicle Signals
 - 9.5.8 Parallel Pedestrian Crossings - Partial Protection by Vehicle Signals
 - 9.5.9 Parallel Pedestrian Crossings - Full Protection by Vehicle Signals
 - 9.5.10 Exclusive Pedestrian Phase
- 9.6 Roundabout Crossings
- 9.7 Grade Separated Crossings
- 9.8 Railway Crossings
 - 9.8.1 Pedestrian Mazes
 - 9.8.2 Lockable Gates

9.1 Sight Lines

Objective

To illustrate the need to provide uninterrupted sight lines at all pedestrian crossing facilities.

Key Points

Visibility between the motorist and the pedestrian must be sufficient for the motorist to stop before reaching the crossing.

Ensure sight lines are maintained at pedestrian crossing locations.

Adequate sight lines are essential at all crossing facilities not controlled by traffic signals and at signalised intersections with parallel pedestrian crossings without full protection from vehicle signals.

Pedestrian crossing facilities should be located where:

- Motorists can see a pedestrian move from the footpath or median onto the road in sufficient time to stop
- Pedestrians can see a vehicle far enough away to safely cross the road before the vehicle arrives



Stirling Street, Perth

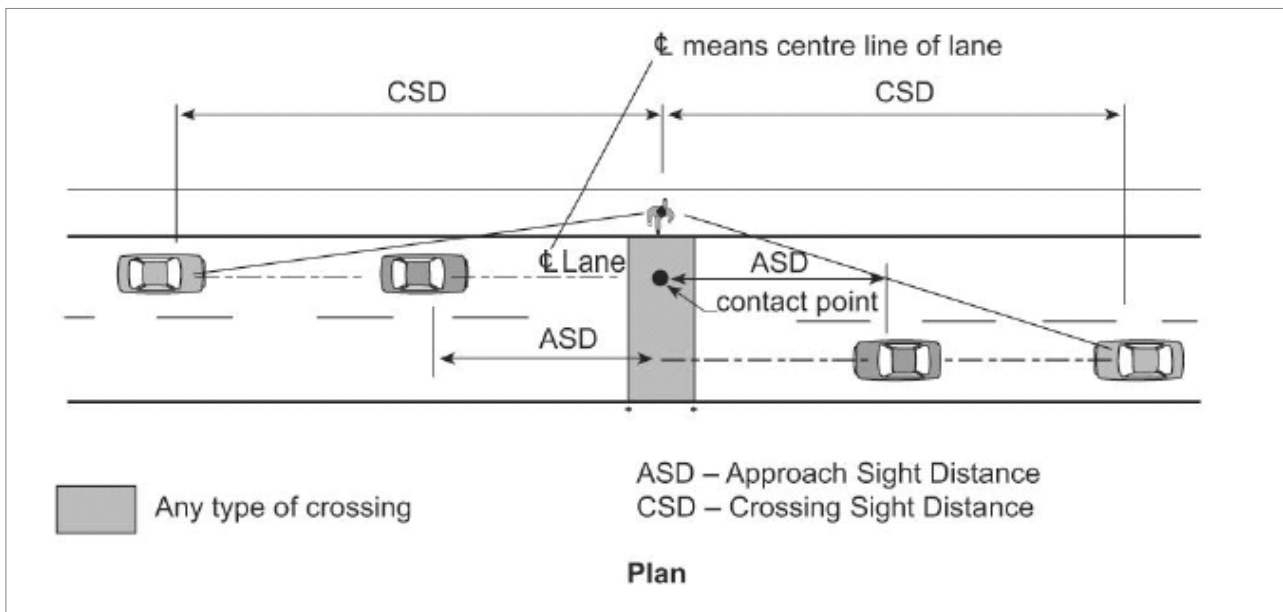

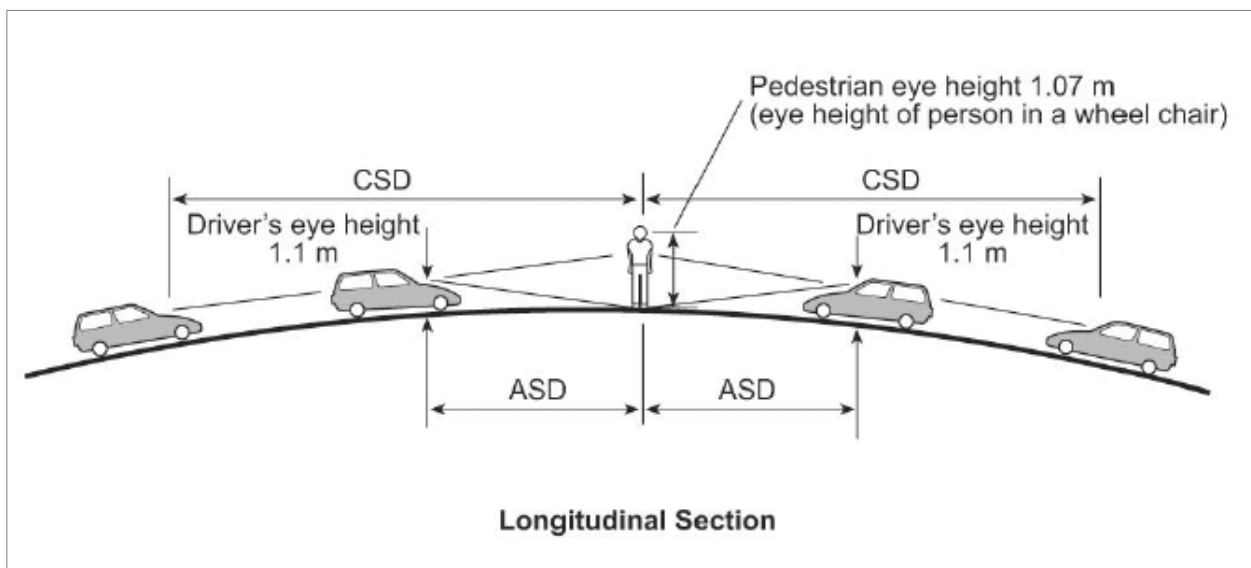

Source: Sight Distances at Pedestrian Crossings – AGRD Part 4A Section 3

Note: MRWA adopt the AS 1742.2 – 2009 specification of an eye driver height of **1.05 m** for assessing sight distance

Approach Sight Distance

Approach Sight Distance (ASD) is the minimum sight distance required for a motorist to observe a pedestrian about to cross the road and to stop before entering the crossing point where:

ASD = Distance travelled during 1.5 secs reaction time + braking distance.

This is equivalent to the minimum desirable Stopping Sight Distance (SSD) for a reaction time of 2.0 secs. In constrained, built-up situations where drivers are likely to be more alert, it may be possible to use the absolute minimum Stopping Sight Distance outlined in AGRD Part 3, Section 5.2.2.

Speed	ASD*	SSD**
40 km/h	35 m	30 m
50 km/h	50 m	40 m
60 km/h	65 m	55 m
70 km/h	85 m	70 m

Motorist Sight Distance

(adapted from AGRD Part 4A Table 3.1, AGRD Part 3 Table 5.4)

*ASD is the desirable minimum sight distance for urban environments (reaction time 1.5 sec)

** SSD is the absolute minimum sight distance for built up, urban environments (reaction time 1.5 sec)

9.1.1 Crossing Sight Distance

Crossing Sight Distance (CSD) is the minimum sight distance required for a pedestrian to see an approaching vehicle in time to judge a suitable gap and cross the road where:

CSD = Distance travelled during the minimum time to safely cross the road.

The crossing distance is based on the width of the carriageway a pedestrian must cross in one movement. A pedestrian refuge splits the crossing into two movements, and so the crossing sight distance can be calculated for each crossing stage. Crossing distances for a single lane are typically 3.5 m (without cycle lane or shoulder) to 5 m (with cycle lane).

Speed	CSD
40 km/h	65 m
50 km/h	85 m
60 km/h	100 m
70 km/h	115 m

Pedestrian Crossing Sight Distance

(assuming 6 seconds to cross a two-lane carriageway at 1.2 m / sec)

Crossing Sight Distance can also be calculated manually using the following formula:

$$\begin{array}{r}
 \text{Crossing Sight Distance} = \\
 \frac{\text{crossing distance (m)}}{\text{Walking speed (m/s)}} \times \frac{\text{85\%ile vehicle approach speed (km/hr)}}{3.6}
 \end{array}$$

This formula allows for variation in the crossing length, and in the pedestrian walking speed. Refer to Section 6.1 for walking speeds for different pedestrians.

9. Pedestrian Crossing Facilities

The following measures need to be taken into consideration in the design and maintenance of pedestrian crossing points:

- Ensure that crossings are appropriately sited with respect to the road geometry, i.e. avoid bends, departure sides of crests
- Ensure sight lines are not obscured by parked cars, vegetation, landscaping, utility poles or street furniture. Minor obstructions of width less than 200 mm can be ignored

Roads with two traffic lanes in the same direction present a hazard when a vehicle in one lane stops for a pedestrian and obstructs the sight line of the pedestrian for a motorist in the other lane. This is a potential problem at a zebra crossing on a one-way street.

Consider kerb extensions at intersections and mid-block crossing points to improve visibility by:

- Preventing motorist parking too close or on a pedestrian crossing
- Providing a highly visible location for the pedestrian to stand adjacent to the traffic lane
- Reducing the crossing distance, which reduces the pedestrian risk exposure time

More information on the benefits and design considerations for kerb extensions is provided in Section 9.3.



Hay Street, West Perth

The pedestrian in this example ran out from between parked cars in front of incoming traffic giving little warning to the motorist.



Yale Road, Thornlie

In this example, the children's crossing is located over the crest of a hill which makes it difficult to see. The warden is also obscured by the pedestrian fence and flag.

9. Pedestrian Crossing Facilities

The visibility of vehicles from this children's crossing is partially obscured by a power pole and also by a fence when viewed by a person in a wheelchair or a short person standing at the top of the kerb ramp.



Stubbs Terrace, Shenton Park

Overgrown bushes in the verge at this intersection obscure pedestrians about to cross this left turn lane.

Local Government Authorities encourage local residents to report overgrown bushes that obscure sightlines or protrude on pathways. Hazard reporting by residents assists staff to locate problems faced by pedestrians. Many of the hazards are not noticed by staff driving around the area.



**Reid Highway/Alexander Drive,
Mirrabooka**

9.2 Pedestrian Crossing Warrants

Objective

To discuss the warrants for the minimum level of pedestrian and traffic demand before pedestrian priority crossing facilities can be considered.

Key Points

In addition to key design requirements, MRWA have minimum requirements for pedestrian and traffic demand at pedestrian priority crossing facilities.

Warrants are different from design requirements for the safe installation of crossing facilities. Design requirements are described in the following sections and include sight distances and vehicle speeds. All warrants should be used as a guide only, with the final decision based on an understanding of local conditions and past experience.

Pedestrian crossing facilities where motorists give way to pedestrians (pedestrian priority) require motorists to be aware of pedestrian activity and to drive with an expectation to stop at a marked or signalised crossing. Crossings which are irregularly used by pedestrians can present a risk, as motorists become accustomed to driving through the facilities without stopping, no longer expecting a pedestrian to cross. For this reason, pedestrian crossing warrants consider the number of pedestrians trying to cross a road in a regular period.

Pedestrian crossing warrants also consider the impact on traffic flows along a road. Consideration is given to the delay caused to motorists stopping for pedestrians, compared to the delay experienced by pedestrians trying to cross a road.

The function of a road, type of demand for the crossing (school, shopping centre, bus stop), and the characteristics of people likely to use the crossing (walking speeds, road safety awareness) should all be considered when assessing the most appropriate form of crossing facility. For roads through built-up activity centres or past schools, changing the road environment (reducing traffic speeds, increasing motorists' awareness of pedestrian activity) may be necessary before a safe crossing can be installed.

The MRWA pedestrian crossing warrants are similar to the warrants previously included in Austroads design guidelines and in AS1742.10 – 2009. The warrants have been removed from recent revisions of Austroads and AS1742.10 – 2009, as different warrant systems are now used across Australia.

The MRWA warrants are described on the following pages. Where a warrant is not met, a crossing facility which doesn't provide pedestrian priority (kerb extensions, refuges) may provide a suitable alternative by reducing the crossing distance. These crossing facilities are discussed in the following section.

Where the pedestrian or traffic demand does not meet the MRWA warrant, but there is a particular demand for a crossing (such as a large proportion of older people), or there are no suitable alternative crossing locations, there are other guidelines which may provide assistance in identifying a safe solution.

An alternative warrant system is used in Queensland and is discussed in this section. An alternative assessment method is also promoted in the WAPC Transport Assessment guidelines for new developments. The use of these alternative guidelines should be discussed with MRWA and / or the relevant Local Government Authority for specific situations.

Note the warrant and approval for a children's crossing is authorised by the Children's Crossings and Road Safety Committee (CC&RSC) and can only be applied for by either a School Principal, or a recognised school/parent organisation.

9.2.1 MRWA Mid-block Crossing Warrants

Zebra and Wombat Crossing Warrant

A zebra crossing may be considered if in two separate hours on an average weekday:

- The number of pedestrians crossing in close proximity of the site (generally within 30 m) exceeds 60 per hour
- The number of vehicles exceeds 600 per hour (total both directions)
- The product of the number of pedestrians crossing and vehicles passing the site exceeds 90,000 in the same hour



Hospital Avenue, Nedlands

Pelican and Puffin Signalised Crossings

A pelican / puffin crossing may be considered if any of the following conditions exist:

(a) For each of 3 hours on an average day:

- Pedestrian volumes exceed 350 persons per hour
- Vehicular traffic exceeds 600 vehicles per hour (one direction) or 1000 vehicles per hour (total both directions) where there is a central pedestrian refuge

(b) For each of 8 hours on an average day:

- The pedestrian volume exceeds 175 persons per hour
- Vehicular traffic exceeds 600 vehicles per hour (one direction) or 1000 vehicles per hour (total both directions) where there is a central pedestrian refuge
- There is no zebra crossing, footbridge or underpass within a reasonable distance.

(c) At a school where, in two separate one hour periods of a typical school day:

- There are no fewer than 50 persons crossing the roadway
- At least 600 vehicles pass the site subject
- The product of the number of pedestrians crossing and vehicles passing in the same hour exceeds 40,000

(d) The pedestrian and traffic volume is sufficient to justify a zebra crossing but pedestrians would be in danger at an 'unprotected' pedestrian crossing. This could be due to the width of the carriageway, traffic speed or traffic volume

(e) A zebra crossing exists and two or more pedestrian accidents of the type susceptible to the correction by signals have occurred on or near the crossing within the past three years

(f) A zebra crossing is justified and pedestrian volumes are very heavy and coincide with high traffic volumes to the extent that excessive delays to road traffic are likely



Fitzgerald Street, North Perth

9.2.2 Warden Controlled Children's Crossing

A warden or guard controlled children's crossing can only be applied for by either a School Principal or a recognised school/parent organisation, by contacting the Children's Crossings Unit (CCU) at WA Police. All applications are referred to the Children's Crossings and Road Safety Committee (CC&RSC) for consideration. The committee includes representatives from the WA Police, MRWA and the Department of Education.

Contact details and application forms are available from the WA Police website:

www.police.wa.gov.au

A location may be approved as either a Type 'A' or a Type 'B' crossing. Following approval a trained crossing guard is appointed by the Police in the case of a Type A crossing and by the school for a Type B crossing.

Type A (Primary School or combined Primary / High School) requires –

- A minimum of 20 students and 200 vehicle movements within the hour immediately before and immediately after school

Type A (High School) requires –

- A minimum of 20 students and 700 vehicle movements occur within the hour immediately before and immediately after school

Type B (Primary School or combined Primary/High School) requires –

- A minimum of 10 students and 100 vehicle movements occur within the hour immediately before and immediately after school

Type B (High School) requires –

- A minimum of 10 students and 350 vehicle movements occur within the hour immediately before and immediately after school



9.2.3 MRWA Left Turn Slip Lane Crossing Warrants

Zebra Crossings at Slip Lanes

Zebra crossing markings should be installed across slip lanes where in the same hour:

- Pedestrian volumes exceed 20 per hour
- Vehicular traffic exceeds 200 per hour



Stirling Highway/Hampden Road, Nedlands

9.2.4 WAPC Traffic Assessment Guidelines for Developments

The Traffic Assessment Guidelines Volume 3 (for Subdivisions) and Volume 5 (Technical Appendix) provide an alternative consideration of the warrant for installing pedestrian priority crossing facilities.

This is based on the volume of traffic as the key factor determining if pedestrians can safely cross a road. As traffic volumes increase the number of gaps large enough for pedestrians to cross decreases, making it more difficult to cross and increasing delays to pedestrians. As volumes increase further, a point is reached at which there are few, if any, gaps of sufficient length for pedestrians to cross safely and delays become significant. This has two potential impacts:

- Pedestrians take risks by crossing in less that desirable gaps
- Pedestrians do not try to cross, or give up after waiting for some time – i.e. the road becomes an impassable barrier

The gap required (or crossing time) for a pedestrian to safely cross the road is based on the width of the road (width of traffic lanes required to be crossed in one movement) and the pedestrian walking speed. A road divided by a pedestrian refuge stages the crossing into two movements, reducing the length of gap required for a pedestrian to safely cross each section of road.

The Traffic Assessment Guideline Volume 3 (Table 4) recommends pedestrian priority crossing facilities be considered once the peak hour traffic exceeds the following volumes:

Road Cross-Section	Maximum traffic volumes providing safe pedestrian gap
2 lane undivided	1,100 vehicles per hour
2 lane divided (with refuge)	2,800 vehicles per hour
4 lane undivided*	700 vehicles per hour
4 lane divided (with refuge)*	1,600 vehicles per hour

* A signalised crossing would be the only appropriate priority crossing facility for roads with more than 1 lane of traffic in each direction.

The traffic volumes in this table are based on a maximum delay of 45 seconds for pedestrians, equivalent to Level of Service E.

This warrant system provides a guide for the ease of pedestrians to cross a road. Before installing a crossing facility which requires motorists to give way to pedestrians, consideration should also be given to motorists' expectation to stop for pedestrians at that location (i.e. the level of pedestrian activity in the vicinity of the crossing). If there is a specific demand for people to cross at that location but low pedestrian volumes, the road environment should be adapted to reflect the conditions to motorists and / or alternative crossing options considered.

9.2.5 Queensland Transport and Main Roads Pedestrian Crossing Guideline

The Queensland Department of Transport and Main Roads (TMR) produced a pedestrian crossing prioritisation workbook following consultation with State and Local Government and community groups. The workbook includes a broader range of assessment criteria than the previous AS1742.10 – 2009 crossing warrants.

The workbook was developed based on extensive research into pedestrian and vehicular flow characteristics, crash performance, road network performance and other relevant attributes. The workbook provides a consistent, quantifiable method to assess the benefits of installing or replacing pedestrian crossing facilities (including crossing aids such as kerb extensions and refuges).

This TMR workbook allocates points to a range of criteria which affect the ease of a pedestrian crossing a road. This includes:

- The delay or Level of Service (LOS) experienced by a pedestrian waiting for a safe gap in a traffic stream
- Pedestrian volumes
- Crash history
- Local traffic conditions
- Pedestrian connectivity

The workbook allows the pedestrian characteristics to be altered to reflect the activities surrounding the site, such as the proportion of pedestrians with disability, older people, children and adults crossing, and the typical walking speed for a specific location.

Based on the information entered for each criteria, the workbook provides outputs on the appropriateness of the following pedestrian crossing facilities for the site:

- Refuges
- Kerb extensions
- Zebra (mid-block)
- Zebra (slip lane)
- Traffic signal (mid-block – puffin or pelican crossing)
- Traffic signal (slip lane)

As the assessment includes a much wider range of factors than the standard warrant systems (such as the MRWA warrants), it can be of assistance for sites with ‘non-standard’ conditions.

The guidelines and workbook are available on the TMR website, in the Traffic and Road Use Management Manual (TRUM), Volume 3, Section 3.13:

- [Pedestrian crossing facility guidelines and prioritisation system user guide](#)
- [Pedestrian crossing prioritisation workbook \(Excel spreadsheet\)](#)

A similar (but slightly more simplified) assessment tool has been adopted in New Zealand.

	Points			
Pedestrian LOS	E	8	Median or Refuge	Possible Treatment
Pedestrian Volumes		3	Kerb Extension	Possible Treatment
Duration of Volumes		0	Zebra (mid block)	Possible Treatment
Pedestrian Crashes		0	Zebra (slip lane)	Possible Treatment
Crossing Sight Distance		0	Children's crossing	Use QT Criteria
Alternative Crossing Points		0	Traffic Signal (mid block)	Just Insufficient Points
Road Network Factors		1	Traffic Signal (slip lane)	Possible Treatment
TOTAL POINTS		12		

Example Results from the TMR Pedestrian Prioritisation Workbook

9.3 Mid-Block Crossings

Objective

To illustrate physical aids within the roadway that can be constructed at mid-block locations to increase the safety and ease of pedestrians crossing the road.

Key Points

Good visibility required.

Minimise the crossing distance that pedestrians are exposed to vehicular traffic.

Provide safe gaps for pedestrians to cross the road.

9.3.1 Crossing Types

Crossing Types – vehicle priority (pedestrians give way to oncoming vehicles):

- Raised medians
- Painted medians
- Pedestrian refuge Islands
- Kerb extensions

Crossing Types – pedestrian priority (vehicles give way to oncoming pedestrians):

- Zebra crossings
- Wombat crossings
- Signalised pelican crossings
- Signalised puffin crossings
- Children's crossings

Facility	Freeway/ motorway	Primary arterial urban / (rural)	Secondary arterial	Collector road	Local street
Refuge / traffic island, median	X	O	O	A	A
Kerb extension	X	X(O)	O	A	A
Road narrowing, indented parking	X	X	X	A	A
Pedestrian fencing	X	O	O	O	X
Speed control device	X	X	X	O	A
Pedestrian (Zebra) crossing	X	X	O	O	A
Children's crossing	X	X	X	O	A
Pedestrian traffic signals	X	A(X)	A	O	X
Grade separated	A	O	O	X	X
Mall	X	X	X	O	O

Legend

- A Most Likely
 O May be appropriate
 X Inappropriate
 X(O) Represents urban/(rural)

Quick Guide to Selection of Crossing Facilities According to Road Classification

Source: AGTM Part 6, Table 8.2.

9.3.2 Raised Medians

Description

Raised medians separate the road into two separate carriageways which enable pedestrians to cross the road as two short one-way roads using the median as a refuge.

Unlike refuges, medians form a continuous divide along the road providing safety benefits for traffic and restricting turning movements where traffic efficiency is an issue.

Raised medians provide a continuous 'safe' crossing option along a long stretch of road (rather than at individual refuge locations). However they will only assist physically able pedestrians, unless specific crossing points are installed with ramps or cut-throughs (gaps) allowing wheeled pedestrian and cyclist movements.

Advantages

- Provides a staged crossing for pedestrians over a length of road
- Provides a safe pedestrian refuge

Disadvantages

- Expensive to construct
- Restricts right turn vehicle access to frontage properties

Preferred Locations

- Existing roads where the pavement width is wider than necessary
- Existing roads with wide road reservations where road widening is feasible
- Proposed roads with four or more lanes
- Where there is a heavy pedestrian movement which is not necessarily concentrated at any particular location
- Where minimal vehicular access is required to frontage properties

Inappropriate Locations

- Narrow roads which cannot be widened
- Along cycle routes with inadequate space to retain cycle lanes alongside a raised median
- Along roads with extensive frontage development requiring vehicular access



St Georges Terrace, Perth



Main Street, Osborne Park

Design Details

- Medians should desirably be at least 2 m in width to provide adequate separation of the opposing carriageways, particularly where traffic speeds are high. A minimum median width of 1.8 m offers protection for a person pushing a pram, a person in a wheelchair, a person with a guide dog or a cyclist. In constrained situations where waiting pedestrians do not need to be accommodated (such as in the middle of a signalised intersection), the absolute minimum median width is 1.2 m which allows for the provision of keep left signs.
- If narrowing the traffic lane, consideration needs to be given to cyclists. If the speed environment on the road is greater than 30 km/h, separate road space should be retained for cyclists alongside the traffic lane and raised median
- Cut-throughs or refuges in the median should be located at regular intervals to provide access for people in wheelchairs and on bicycles (minimum every 100 m). Cut-throughs are preferable for medians up to 10 m wide (must be installed for medians less than 4.5 m wide)
- The cut-through width is typically 2.5 m but may range from 2 m to 3 m or even greater if the gap is combined with a zebra crossing
- Cut-throughs should be perpendicular to the road to direct sight impaired pedestrians to the opposite ramp
- Edge lines should be painted across gaps together with tactile indicators to assist sight impaired pedestrians identify the road edge
- Grab rails may be provided if the median width is at least 2 m
- Parking restrictions and / or kerb extensions should be installed where existing parking restricts the pedestrian sight distance at crossing ramps to the central median



West Coast Highway, City Beach

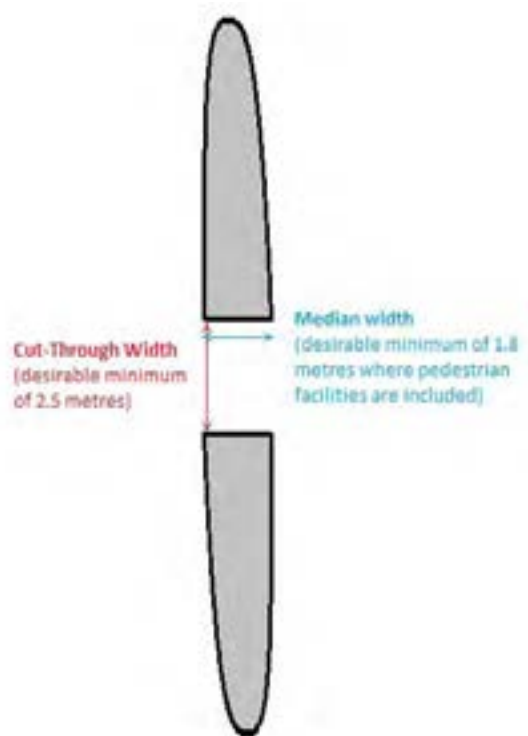

Recommended dimensions for pedestrian facilities in medians

9.3.3 Painted Medians

Description

Painted medians can be used instead of raised medians, often in conjunction with pedestrian refuge islands.

Painted medians form a continuous divide along the road providing safety benefits for traffic, whilst still allowing for vehicle turning movements.

Painted medians provide a continuous 'safe' crossing option along a long stretch of road, but do not provide as much protection as a raised median or refuge.

Advantages

- Provides a staged crossing for pedestrians over a length of road
- Low installation cost
- Can reduce vehicle speed and improve safety along roads with excessive traffic lane widths
- Does not restrict right turn vehicle access to frontage properties

Disadvantages

- Low level of pedestrian security
- Cannot be used to install grab rails or signs

Preferred Locations

- Existing roads where the pavement width is wider than necessary
- Where there is a pedestrian movement which is not necessarily concentrated at any particular location
- Where vehicle access is required to frontage properties

Design Details

- Minimum widths are the same as raised medians, where painted medians are installed to assist pedestrian crossing movements

Inappropriate Locations

- Narrow roads, or cycle routes where there is inadequate space for cycle lanes alongside the painted median
- Where there are high concentrations of pedestrians crossing the road and more secure pedestrian crossing treatments should be examined



Beaufort Street, Highgate



Albany Highway, East Victoria Park



Brookdale Street, Floreat

9.3.4 Pedestrian Refuge Islands

Description

Pedestrian refuge islands are one of the most basic but also one of the most effective devices to assist pedestrians across the road. They are usually located centrally in the road and enable pedestrians to cross one direction of traffic at a time.

The simplest form of pedestrian refuge is an isolated concrete island. This can be particularly useful where there is a concentration of pedestrians and it is difficult to cross the full width of the road in one stage. Kerb extensions can be used in conjunction with the refuge island to further reduce the road width.

Concrete islands may be used with a painted median where pedestrians cross over a significant length of the road. The spacing of the islands is normally at 200m to 300m apart which provides an acceptable separation for pedestrians and avoids a wide painted median being used by drivers as an overtaking lane.

Advantages

- Provides a staged crossing at locations where pedestrian crossing movements are concentrated
- Provides a safe pedestrian refuge
- Relatively low cost
- Causes little restriction to right turn vehicle access to frontage properties

Disadvantages

- May require minor road widening in certain situations

Preferred Locations:

- Roads with wide lanes or where short sections of road widening is feasible
- Where pedestrian crossing movements are concentrated

Inappropriate Locations:

- Roads with high traffic speeds and restricted visibility
- Locations where the numbers of pedestrians and vehicles justify a higher level of pedestrian crossing
- Narrow roads, or cycle routes with inadequate space for cycle lanes



Cantonment Street, Fremantle



Lissiman Street, Gosnells



Almadine Drive, Carine

Design Details

- Refer to MRWA standard drawings 200331-139 (lane width ≤ 5.5 m), 200331-140 (lane width > 5.5 m)
- AGRD Part 4, Section 8.2.2 and Commentary 5 and 6 provide more design information
- The minimum island width is 1.8 m to accommodate a person pushing a pram, in a wheelchair, with a guide dog or a cyclist standing across the direction of traffic flow.
- Where waiting pedestrians do not need to be accommodated (such as in the middle of a signalised intersection), in constrained situations the absolute minimum island width is 1.2 m which allows for the provision of keep left signs
- A cut-through is to be provided in the island to allow a pedestrian to cross the road without having to negotiate a kerb. The width of the gap or cut-through is typically 2.5 m but may range from 2 m to 3 m or even greater if the gap is combined with a zebra crossing
- If narrowing the traffic lane, consideration needs to be given to cyclists. If the speed environment on the road is greater than 30 km/h, separate road space should be retained for cyclists alongside the raised median
- Parking restrictions are preferred within 20 m of the island. This is MRWA practice but is no longer required under the current road traffic code. An alternative is to install kerb extensions to improve pedestrian sight distance at the refuge crossing point
- Grab rails may be provided if the island is at least 2 m wide
- If the refuge is combined with a zebra crossing and the median width is greater than 2.4 m, it may be appropriate to stage the pedestrians using a chicane or angled crossing to avoid excessive delay to motorists (refer to AGRD Part 4, Figure 8.2 for more information)
- Street lighting should be provided as per AS/NZS1158.3.1 – 2005 and AS/NZS1158.4 – 2009 (Section 10.1)

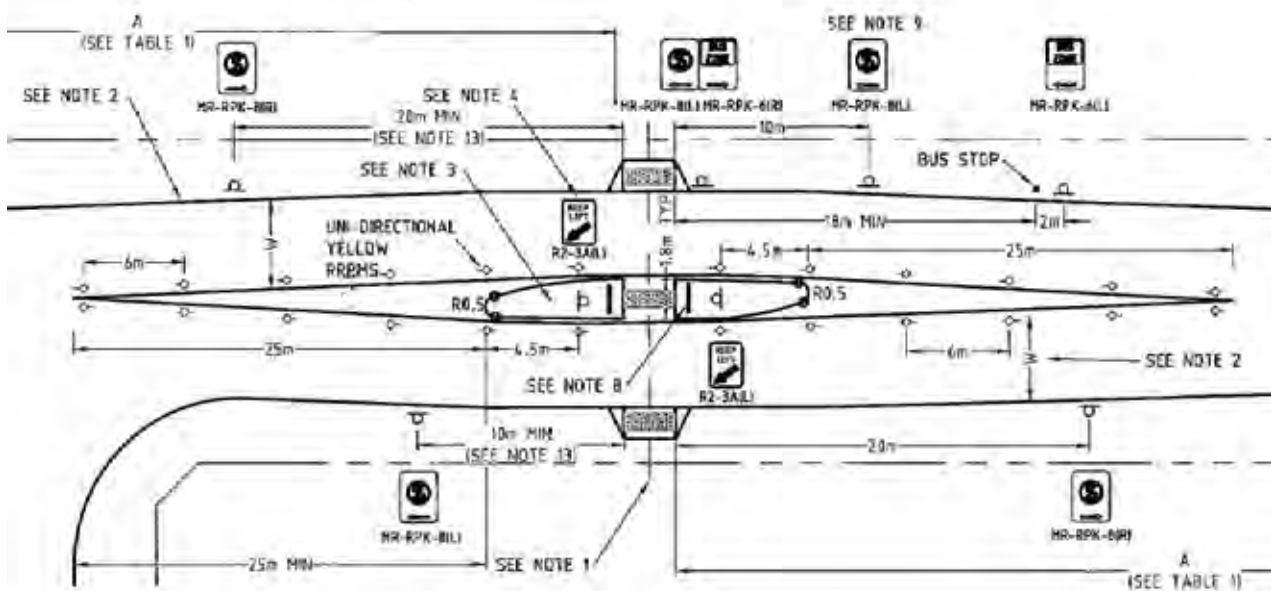

MRWA Standard Drawing 200331-139; Pedestrian Refuge Island for Lane Width ≤ 5.5 m

9.3.5 Kerb Extensions (or Nibs)

Description

Kerb extensions are also known as footpath extensions and pedestrian nibs. They involve local widening of the footpath into the carriageway by using an adjacent shoulder or parking lane.

The extended footpath shortens the crossing distance to the other side of the road and also makes both pedestrians more visible to approaching motorists and conversely approaching vehicles more visible to pedestrians.

Kerb extensions may be constructed at intersections and mid-block locations. They are often used in conjunction with refuges and zebra crossings, and can be used at slow points as part of local area traffic management treatments.

An edge line should be painted on the approach and departure side of kerb extensions to guide cyclists.

Advantages

- Reduces the width of road that pedestrians have to cross
- Improves the visibility between pedestrians and motorists, particularly where vehicles are parked on the side of the road
- May reduce the speed environment by narrowing the roadway
- Relatively low cost

Disadvantages

- Can be a safety hazard to motorists if the kerbside parking lane is empty and is mistaken for a traffic lane
- Reduces the availability of kerbside parking

Preferred Locations

- Sites with restricted sight distances
- Shopping areas and other locations where there is high pedestrian demand and the kerbside lane is used for parking and is not required as a traffic lane
- In combination with local area traffic management treatments such as road humps and slow points



Hay Street, West Perth



Lissiman Street, Gosnells



Harper Street, Victoria Park

Inappropriate Locations

- Roads where the kerbside lane is needed by moving traffic during peak periods
- Locations where the numbers of pedestrians and vehicles justify a higher level of pedestrian crossing
- High speed roads
- Cycle routes where there is inadequate space for cycle lanes alongside the kerb extension

Design Details

- AGRD Part 4, Section 8.2.2 and Commentary 6 include design details on kerb extensions
- Local government authorities may have standard drawings for kerb extensions and parking embayments within their district
- The width of kerb extensions can be extended to the parking lane line (usually 2.3 m to 2.5 m wide)
- It is desirable to reduce the crossing distance between the extensions to a maximum of 10 metres (allows for two traffic & two cycle lanes)
- On slower speed roads the crossing distance between extensions can be further reduced to match the traffic lane width
- The length is typically 6 m to 10 m long, restricting parking to achieve the minimum sight distances at the crossing
- This treatment is often carried out in combination with the embayment of parking
- Street lighting should be provided as per AS/NZS1158.3.1 – 2005 and AS/NZS1158.4 – 2009 (Section 10.1)

Less Preferred Practice

Paving on the roadway is sometimes provided in conjunction with kerb extensions as part of a streetscape or traffic calming treatment. This type of treatment should be avoided because it can cause uncertainty for both pedestrians and motorists over who has the right of way. At some locations signs advising “PEDESTRIANS GIVE WAY TO THROUGH TRAFFIC” have had to be installed.



Hay Street, Subiaco

9.3.6 Zebra Crossings

Description

Zebra crossings rely on the motorist seeing the pedestrian on the crossing and then slowing down or stopping to allow the pedestrian to cross the road.

Traffic regulations require the motorist to give way to pedestrians on the crossing. If a children's guard controlled crossing is in place at the zebra crossing, traffic must wait until all pedestrians have cleared the crossing before continuing. .

Since the 1970's, MRWA has replaced a large number of zebra crossings on high volume roads with raised medians or pedestrian refuge islands. This action resulted in a reduced number of pedestrian and vehicular crashes after the zebra crossings had been removed. However, a major reason for the crash reduction was that the zebra crossings had been installed on busy multi-lane roads which were inappropriate for this type of treatment. Zebra crossings should still be considered as viable crossing facilities where conditions are appropriate.

Warrants for zebra crossings are discussed in the previous section (Section 9.2).

Good sight distance and lighting are a requirement for the safe operation of this facility.

Advantages

- Relatively low cost to install and maintain
- Less delays to motorists than signalised crossings

Disadvantages

- Pedestrians often assume all motorists can/or will stop and give way
- Can be poorly respected by motorists, especially where pedestrian volumes are low
- Good visibility required

Preferred Locations

- Two-lane roads with short crossing distances, low traffic speeds, low traffic volumes, consistent pedestrian usage throughout the day, street lighting and good visibility of the crossing
- Left turn slip lanes (see traffic signal controlled crossings)
- Roundabouts with high pedestrian usage



Albany Highway, East Victoria Park



Marine Parade, Cottesloe



Albany Highway, Victoria Park

Inappropriate Locations

- On busy multi-lane roads
- On high-speed roads (>60 km/h)
- Where sight distance is restricted
- Where there is no street lighting
- Where there is inconsistent pedestrian usage

Design Details

- Refer to MRWA standard drawing 200331-164
- AGRD Part 4, Section 8.2.3 and Commentary 7 and 8, and AS1742.10 – 2009 Clause 6 include further design discussion
- Zebra crossings can only be installed on roads with:
 - No more than one lane of traffic in each direction
 - Adequate sight distance for vehicles and pedestrians (refer Section 9.1)
 - A maximum posted speed limit of 50 km/hr (excluding slip lanes), and maximum 85%ile speed of 60 km/h
- Kerb protrusions and / or a wombat road hump can be used to improve visibility, reduce the crossing distance and slow traffic through a busy activity area
- Refuges can be used to stagger the crossing into two movements
- The width of painted lines on zebra crossings range between 3 m and 6 m; MRWA standard is 3.7 m

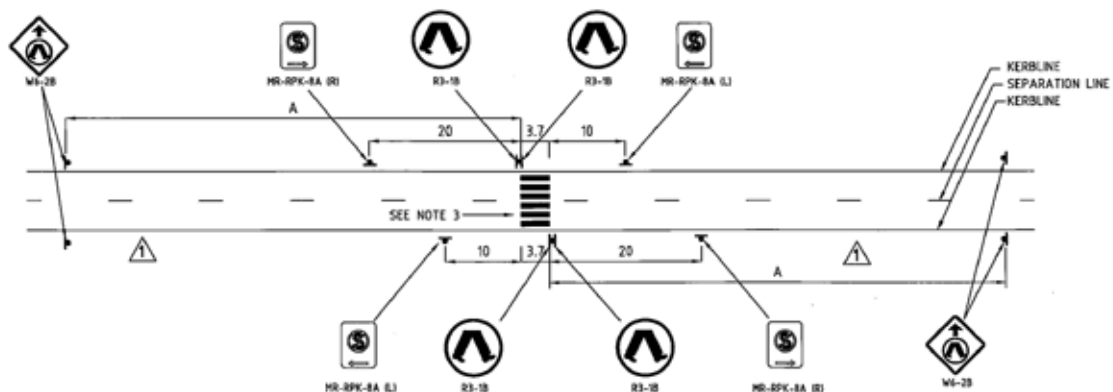

MRWA Standard Drawing 200331-164: Pedestrian Zebra Crossing

9. Pedestrian Crossing Facilities

- The painted lines are to be white, 0.6 m wide, with 0.6 m spacing between the lines
- The Pedestrian Crossing sign (R3-1B) is to be installed on both approaches to the crossing
- The Pedestrian Crossing Ahead (W6-2B) advance warning sign is to be installed where there is limited visibility of the Pedestrian Crossing signs (for distances see note 1 MRWA Standard Drawing 200331-164)
- For crossings without kerb protrusions, parking must be restricted for a minimum of 20 m on the approach and 10 m on the departure side of the crossing to achieve minimum sight distances
- Lighting specifications for zebra crossings is outlined in AS/NZS1158.4 – 2009, Table 3.1, 3.2 and 3.3 (see Section 10.1)



Irwin Street, Hay Street, Perth

Example

Ensure that the zebra crossing is located on, or as close as practical, to the pedestrian desire line. In this example, the two underpasses are some distance from the crossing. This could reduce the use of the crossing facility, with pedestrians instead opting to cross at a less safe location.



Railway Parade, Maylands

Example

Located adjacent to Hollywood Private Hospital and a nearby primary school, the provision of a zebra crossing is appropriate here due to the higher proportion of elderly and hospital patients in a low speed environment with adequate sight distances.

Note: The ramps on either side of the pedestrian crossing should also include TGS1



Monash Avenue, Nedlands

Example

A signalised crossing may be more appropriate where there is high pedestrian use and high vehicle volumes. In this example, the zebra crossing has been changed to a Puffin crossing.



Hay Street, West Perth

9.3.7 Wombat Crossings

Description

A wombat crossing is a zebra crossing on a raised plateau at footpath level.

This type of treatment is suitable in a low speed environment, typically 40 km/h or less.

Advantages

As for a zebra crossing plus:

- The raised platform improves the visibility of the crossing and forces motorists to slow down

Disadvantages

As for a zebra crossing.

Preferred Locations

- Two-lane roads with short crossing distances, low traffic speeds, consistent pedestrian usage throughout the day, street lighting and good visibility of the crossing
- Residential roads not used as bus routes

Inappropriate Locations

As for a zebra crossing plus:

- On bus routes and other routes used by heavy vehicles that could be adversely affected by the raised platform



Hay Street, Subiaco



Lissiman Street, Gosnells

Design Details

As for the zebra crossing plus:

- Refer to MRWA standard drawing 200631-0001
- AGTM Part 8, Section 7.2.4 and AS 1742.10 – 2009 Clause 6 provide design information for wombat crossings
- The recommended platform height is 100 mm, except for bus routes where a maximum platform height of 75 mm is to be used
- The approach ramp for motorists is a minimum of 1.2 m, up to 1.5 m on bus routes, and a maximum 1:20 grade on cycle routes

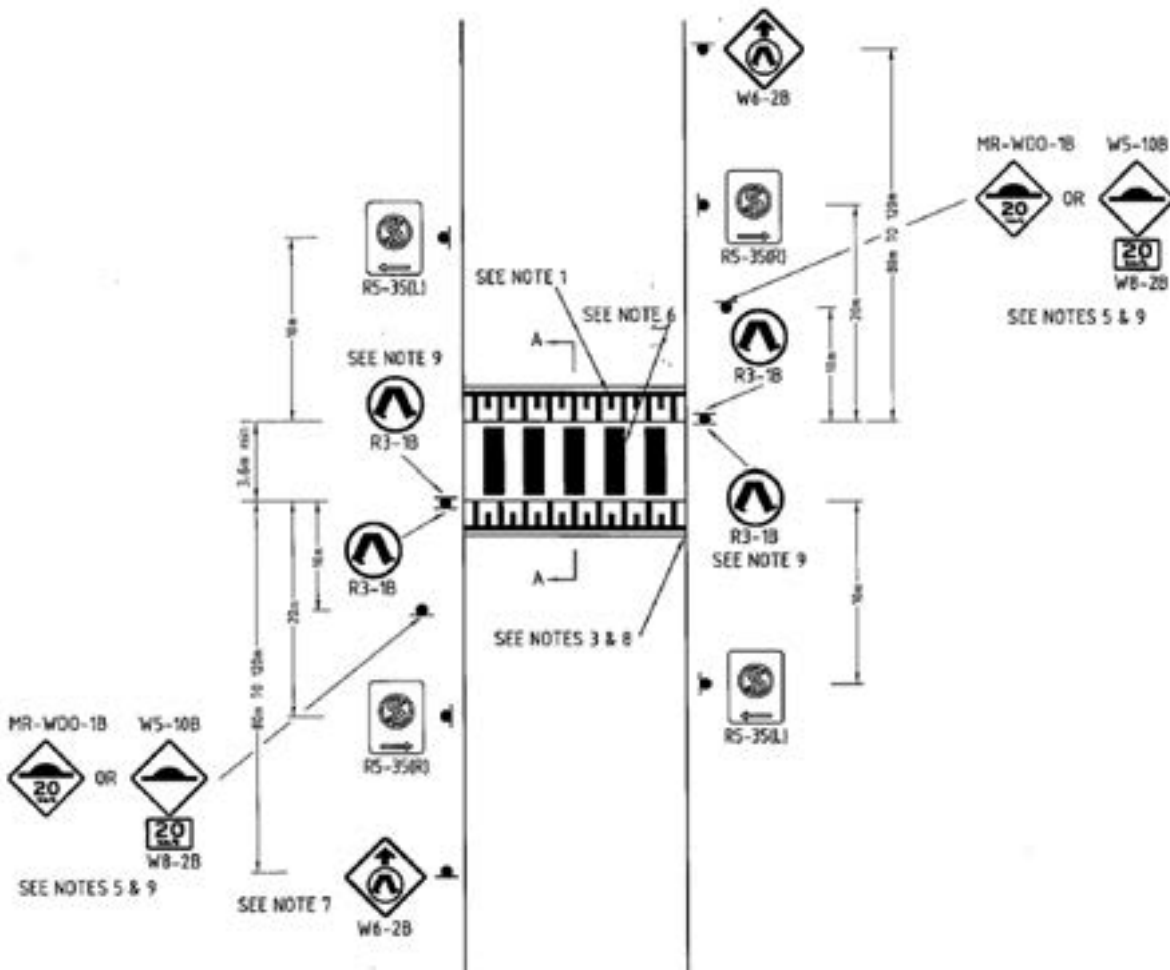

MRWA Standard Drawing 200631-0001: Road Hump – Wombat Crossing

- The platform surface material must provide adequate contrast with the white zebra crossing markings; for this reason brick paving is not suitable, along with maintenance issues as paint does not adhere well to brick (black or coloured asphalt is preferred)
- The platform should extend the full width of the roadway, and can be installed in combination with kerb extensions to reduce the crossing distance and improve visibility
- A road hump warning sign (W5-10B) is to be installed in advance of the wombat crossing as specified in MRWA standard drawing 200631-0001. Advance warning signs (W6-2B) should also be installed where there is limited visibility of the Pedestrian Crossing signs

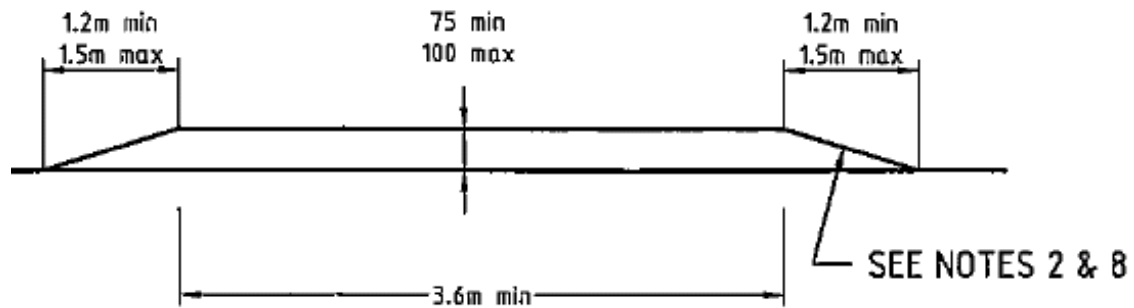

HUMP DETAIL
SECTION A-A

MRWA Standard Drawing 200631-0001: Road Hump – Wombat Crossing

Non Conforming Design

Zebra and Wombat crossings are often used in shopping centres where non-conforming signing and pavement markings are common. However, they provide improved safety for pedestrians in a busy but slow vehicle environment.



Carousel Shopping Centre, Cannington

In this case the markings on the approach ramp do not extend all the way to the top of the crossing platform.



Hay Street, Subiaco

Raised plateaus without zebra markings can confuse both pedestrians and motorists over who has right of way.

9.3.8 Mid-Block Signalised Crossings - Pelican Crossings

Description

Pelican crossings (**P**edestrian **L**ight **C**ontrol Crossing) are pedestrian activated traffic signals located at mid-block locations. They are used where pedestrian crossing activity is concentrated along short sections of road carrying high traffic volumes.

The signal sequence is similar to signals at signalised intersections except that a flashing yellow period is included for motorists soon after the display of the flashing red figure commences for pedestrians. Drivers may then proceed through the crossing with caution during the flashing yellow phase but must give way to pedestrians still on the crossing.

Warrants for pelican crossings are discussed in the previous section (Section 9.2).



St Georges Terrace, Perth

Advantages

- Pedestrians using the crossing are protected
- Suitable for pedestrians with a visibility or mobility impairment
- Delays to motorists are minimised due to the inclusion of a flashing yellow phase

Disadvantages

- Expensive to install and maintain
- Slow pedestrians may still be on the road when vehicles are released
- Vehicles are unnecessarily held when the crossing is clear

Preferred Locations

- Locations with high pedestrian crossing volumes and high traffic volumes
- Where a zebra crossing is warranted, but the site is adjacent to a railway level crossing, close to a signalised intersection or within a coordinated traffic signal system, or caters for a large number of pedestrians with disability, a signalised crossing may be more suitable than a zebra crossing

Inappropriate Locations

- Roads with a speed limit ≥ 70 km / hr
- Where pedestrians cross over a long section of road
- Where pedestrian crossing volumes and traffic volumes are low
- Close to an intersection (should be combined with a signalised intersection treatment)

Design Details

- Refer to MRWA standard drawing 200431-0116
- AGRD Part 4, Section 8.2.3, and AS1742.10 – 2009 Clause 8 (particularly 8.5) include further design information

9.3.9 Mid-Block Signalised Crossings - Puffin Crossings

Description

The Puffin crossing (**P**edestrian **U**ser **F**riendly **I**ntelligent Crossing) is a development of the Pelican crossing.

Above ground detectors sense the presence of people crossing the road and adjust the crossing times as required. Extra time is allocated for slower moving pedestrians such as the elderly and people with disability. Conversely, the pedestrian phase can be reduced if a pedestrian is not detected.

The technology used in the Puffin crossing aims to improve the efficiency and acceptability of the pedestrian crossing for motorists and also provides more flexible operation for pedestrians.

All future mid-block signalised pedestrian crossings will be Puffins. However, there are no current plans to upgrade the existing Pelicans to Puffins.

The Puffin crossings in WA differ to the detection methods used at UK Puffin crossings. In the UK all new signalised pedestrian facilities include kerbside detectors as well as the above ground (on-crossing) detectors used in WA (shown in the adjacent photo). The kerbside detectors ensure a pedestrian phase is only run if a pedestrian is still waiting to cross the road. This further improves efficiency and avoids unnecessary demand for pedestrian phases.



Fitzgerald Street, North Perth



Pedestrian Detector

9.3.10 Warden Controlled Children's Crossings

Description

Children's crossings are controlled by trained wardens who have the authority to stop traffic and allow school children and other pedestrians to safely cross the road.

They are provided where there is a concentration of children crossing a busy road in the vicinity of a school. The crossing is only supervised for short periods before and after school hours and does not restrict motorists at other times of the day.

Children's crossings can be installed at busy signalised intersections or zebra crossings to provide additional safety for children crossing.

Approval for a children's crossing is through the WA Police, as outlined in the warrant information in Section 9.2.

Advantages

- Pedestrians using the crossing are fully protected
- The children are controlled by the crossing warden who provides an adult assessment of when it is safe to cross
- The crossing warden is able to balance the flow of traffic against the demand for pedestrians to cross the road
- Unnecessary restrictions are not imposed on drivers outside the start and finish of normal school hours.

Disadvantages

- Expensive to provide a crossing warden
- More than one warden may be required on a busy road.

Preferred Locations

- On pedestrian routes used by children moving to and from school
- Mid-block locations clearly visible to approaching motorists.

Inappropriate Locations

There are many existing children's crossing at locations which may not be desirable but are not inappropriate, these can include:

- At locations other than near schools
- Adjacent to intersections and roundabouts where turning vehicles may conflict with the crossing
- On roads with a posted speed limit of 80 km/h and above.



Spencer Road, Thornlie



Osmaston Road, Carine

Design Details

- Refer to MRWA Standard Drawing 9120-174 and 9531-2169
- AS1742.10 – 2009, Clause 7 provides more design information
- Children’s crossings can only be installed on roads with:
- No more than one lane of traffic in each direction; except where the crossing is supervised by trained adult wardens
- Adequate sight distance for vehicles and pedestrians(refer Section 9.1)
- Kerb extensions and / or refuges can be used to improve visibility and stagger the crossing into two movements
- Pedestrian guideline markings are to be installed, 3.5 m apart aligned with the kerb crossing ramps (min. 2.4 m crossing gap)
- A 0.3 m vehicle stop line is to be installed, 6m back from the crosswalk lines
- The Children Crossing sign (W6-3B) is to be installed on both approaches to the crossing, with the supplementary ‘Crossing Ahead’ sign (W8-22B) where the crossing is not located in a school speed zone
- Children Crossing flag (R3-3) to be displayed whilst the traffic warden is in attendance
- Either red and white bollards or flashing yellow signals (wig wag) are to be installed adjacent to the vehicle stop line, as per the MRWA standard drawings outlined opposite and on the next page
- For crossings without kerb protrusions, parking must be restricted for a minimum of 20 m in advance of the vehicle stop line, and 10 m on the departure side of the crosswalk lines to achieve minimum sight distances

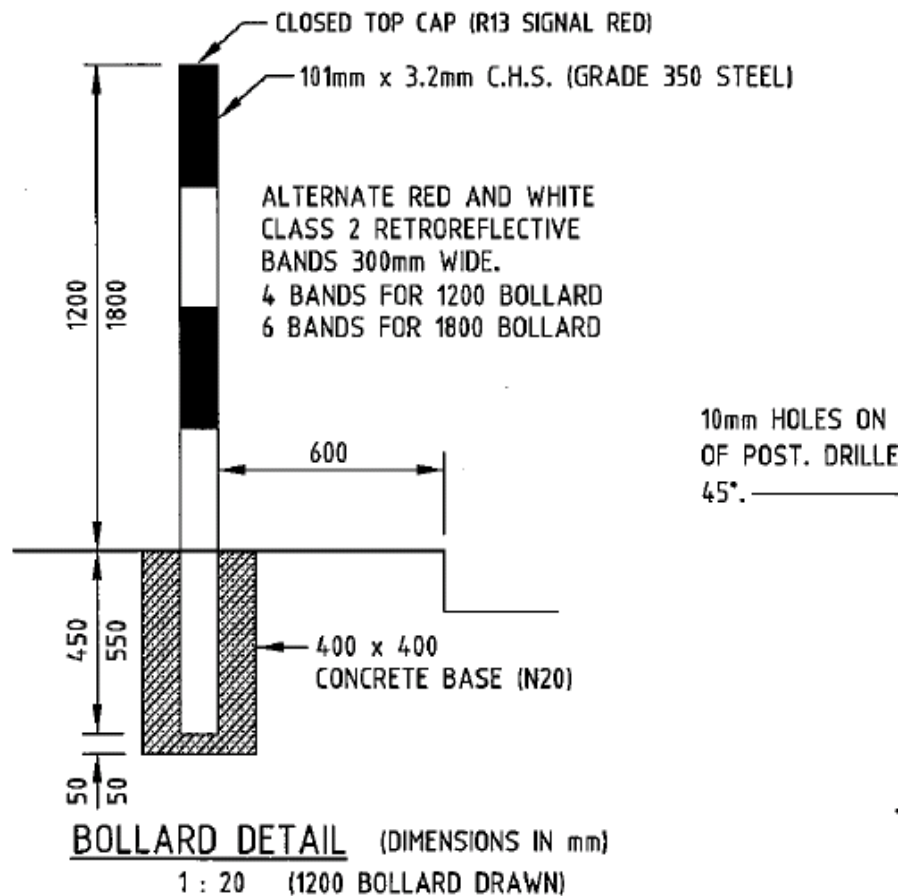

Children Crossing Bollard Detail – MRWA Standard Drawing 9120-174

Flashing Signal Detail (Wig Wag)

Flashing signal poles, also known as a wig wags, can be installed at a children’s crossing in place of the red and white bollard.

The installation of flashing signal poles is determined by MRWA on a case-by-case basis. Generally these are only used where there is an increased safety risk at the crossing location, such as on high volume, distributor roads or sites with restricted sight distances.

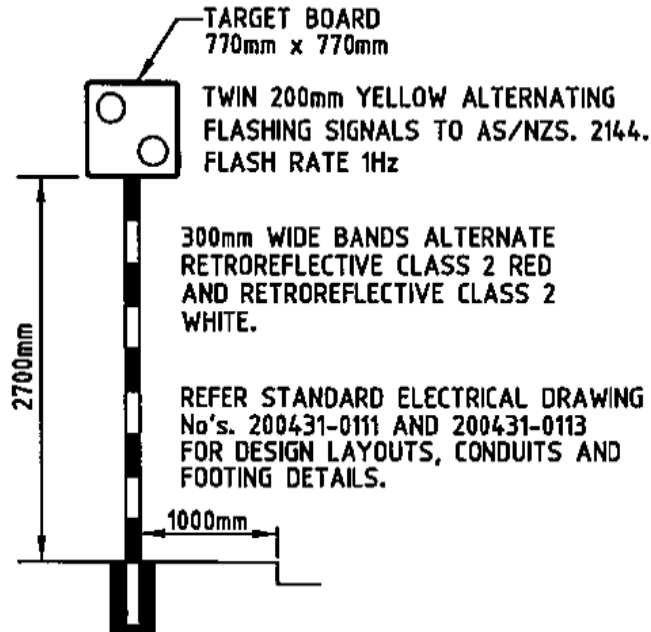

TRAFFIC SIGNAL POLE DETAIL (DIMENSIONS IN mm)

Children Crossing Flashing Signal Detail (Wig Wag) – MRWA Standard Drawing 9531-2169

Innovations

Overhead flashing lights and red and white striped signal posts have been trialled to improve the visibility of some crossings. However, this facility is costly and should be used sparingly.

MRWA are currently developing a warrant for the appropriate use of the overhead and standard wig wag flashing lights at children crossings.



Albany Flashing Signal Crossing

9.4 Non-Signalised Intersection Crossings

Objective

To illustrate pedestrian facilities at intersections controlled with give-way or stop signs, which reduce conflict between pedestrians and vehicles.

Key Points

Pedestrians at unsignalised intersections have priority over vehicles turning into the street the pedestrian is crossing.

Intersections can be designed to reduce conflict for pedestrians and provide safe crossing opportunities.

Non-signalised intersections present a potential conflict between crossing pedestrians and turning traffic. The Road Code requires turning vehicles to give way to pedestrians. However this is not always observed and pedestrians must be able to assess the risk of conflict before entering the roadway (difficult for younger children).

Pedestrian refuges improve safety for pedestrians at non-signalised intersections, particularly across wide roads or where the traffic is heavy.

Ramps should direct pedestrians in the direction of travel which may require angled ramps to be installed.



Pedestrians have priority over turning vehicles entering the street



Floreat Beach Road, City Beach

Kerb Radii

Kerb return radii should be kept to a minimum to:

- Reduce the speed of vehicles turning into a side road
- Assist in locating the pedestrian crossing close to the corner.

Liveable Neighbourhoods recommends a 6 m kerb radius for an Access Street. Access Street intersection and a 9 m kerb radius for an Access Street. Neighbourhood Connector Intersection.

AGRD Part 4, Section 5 and AGRD Part 4A Section 8.3 provide information on the appropriate design vehicle and recommended kerb radii for different road types and carriageway widths. For local roads, the kerb radii are generally designed to accommodate a rubbish truck or removal van.

Larger radii may be necessary on higher speed roads with a high traffic function to improve the efficiency of the intersection and reduce the risk of rear end crashes.



Higher Speed Kerb Radii.

Albany Highway and Dudley Road, Kenwick.



Lower Speed Kerb Radii.

Beaufort Street and Grosvenor Road,
Mount Lawley

The UK Manual for Streets goes much further in suggesting that kerb radii should be reduced further on local streets, and designed to keep pedestrian desire lines as straight as possible, minimising deviation and assisting the partially sighted in orientating themselves at intersections.

Large vehicles may be required to use the full width of the road (acceptable on low volume and low speed roads).

The use of kerbs to separate the footpath and carriageway has the benefit of facilitating drainage of surface water and allowing partially-sighted pedestrians to find their way around. However, kerbing can suggest implicit priority to vehicles on the carriageway and providing crossing points at junctions which are flush with the road, but with appropriate tactile paving, can have some benefits, particularly for the mobility impaired.

This can be achieved by:

- Raising the road to the same level as the footpath at the intersection; and
- Providing a raised table at T-intersections and crossroads.

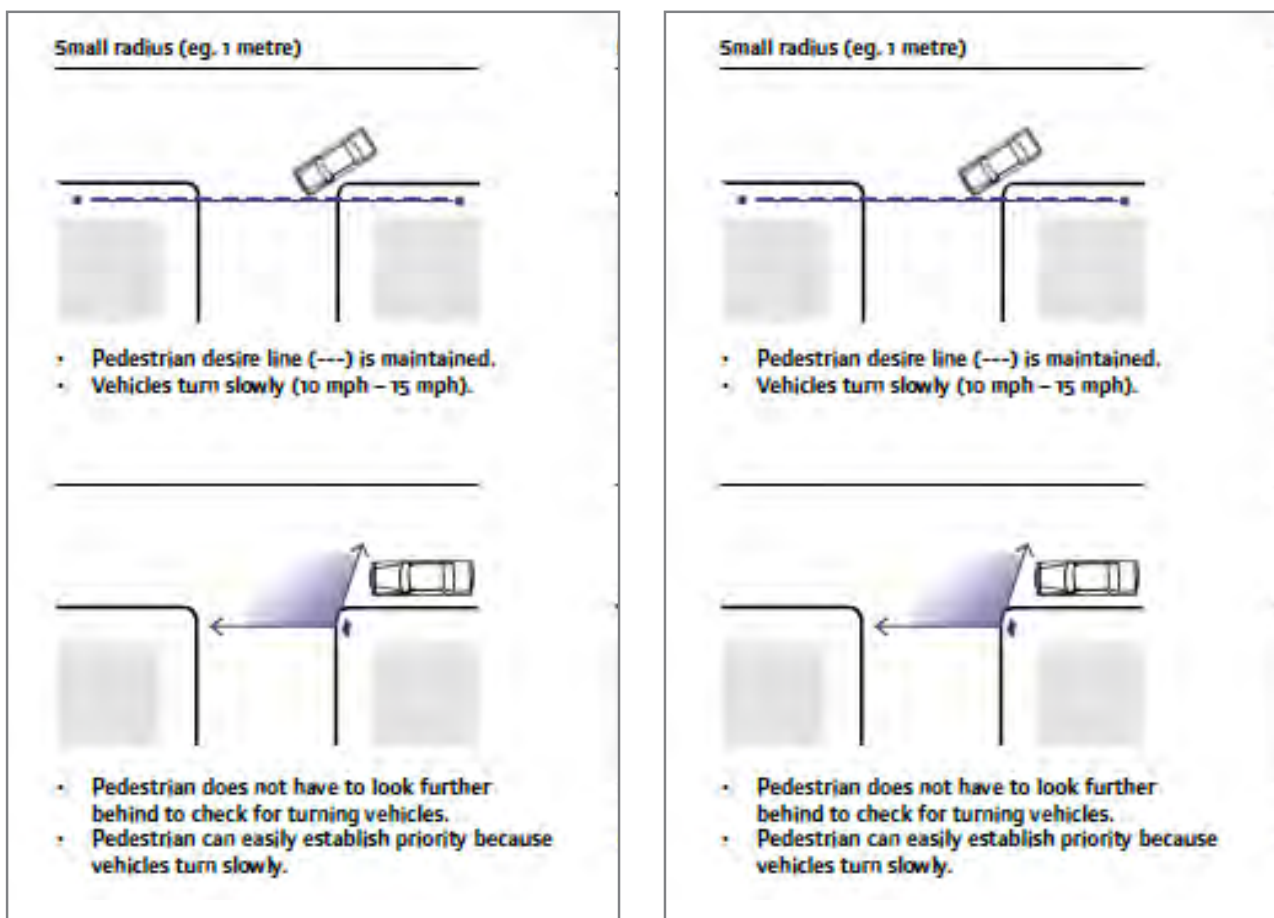

Source: Manual for Streets (UK Department for Transport, 2007)

Set-Back of Crossing from Intersection

Provided there are no buildings or other obstructions at the intersection which restrict sight lines, there are benefits to locating the crossing at the tangent point of the kerb return because:

- A pedestrian crossing the road is more visible for a left turning motorist
- The crossing distance is shorter
- It is easier to construct the ramps so that they direct pedestrians through the crossing

The deviation of the pedestrian path should not be excessive or it will discourage its proper use.



Bourke Street and Oxford Street, Leederville

Staggered Crossings

Crossings may be staggered in the median to provide better visibility and warning of right turning vehicles. The slight shift away from the intersection also reduces the crossing distance across the carriageway since the median nose at an intersection is usually tapered to accommodate the swept path of a truck.



Marmion Avenue and Almadine Drive, Carine

Note: TGSI should be installed in the ramp shown in the adjacent photo

Design Details

There are a number of MRWA standard drawings for intersections at grade which include details on pedestrian facilities. These include, but not limited to:

200131-0084 Intersections at Grade – Sheet 4 of 8 Austroads Rural Right Turn Type ‘C’ High Entry Angle for Left Turn Slip Lane

200131-0085 Intersections at Grade – Sheet 5 of 8 – Free flow Left Turn Slip Lanes, Auxiliary Acceleration Lanes & Seagull Island Alternative Dual Carriageway in Major Road

200331-141 Typical Treatment for Median Island – Intersection Median Island

2000331-142 Typical Treatment for Median Islands – Left In, Left Out Partial Closure

200631-0002 Typical Treatment for Seagull Closures – Left Turn Entry and Exit Only

201131-0001 Typical Treatment for Entry Statements – Raised Pavement at T-Junction

9.5 Signalised Intersection Crossings

Objective

To illustrate facilities at traffic signalised intersections that regulate the conflict between pedestrians and vehicles.

Key Points

Pedestrians have priority at signalised intersections over vehicles turning into the street the pedestrian is crossing.

Traffic signals protect pedestrians while crossing the road but can result in significant delays to both motorists and pedestrians.

General

- Design Details
- Signal Displays
- Timings
- Staged Crossings
- Left Turn Slip Lanes

Signalised Intersections

- Parallel Pedestrian Crossings - No Protection by Vehicle Signals
- Parallel Pedestrian Crossings - Partial Protection by Vehicle Signals
- Parallel Pedestrian Crossings - Full Protection by Vehicle Signals
- Exclusive Pedestrian Phase

9.5.1 Design Details

Design information for pedestrian facilities at signalised intersections is provided in the following references:

- MRWA Guidelines for Pedestrian Signals (D08#6040)
- AGRD Part 4A, Section 10.6.3
- AS1742.14 – 1996
- Information on audio-tactile push buttons is provided in Section 8.4

Pedestrian guideline markings should be installed:

- At a width of 2.4 m – 3 m (absolute minimum width of 2 m), and up to 10 m where there is a large pedestrian demand
- With at least 0.8 m separation from the vehicle stop line

Vehicles turning at traffic signals are legally required to give way to pedestrians crossing the section of carriageway the vehicle is entering.

To provide extra protection for crossing pedestrians, turning vehicles can be delayed for part or all of the pedestrian crossing time.

Pedestrian crosswalk markings provided at right angles (parallel crossings) are preferred as this:

- Minimises the crossing distance and crossing phase time
- Assists with orientation for vision-impaired pedestrians, including the TGSI layout

At sites with a large pedestrian demand, an exclusive diagonal pedestrian phase should be considered.

9.5.2 Signal Displays

Symbolic Pedestrian Signals

Symbolic pedestrian signals and audible tactile facilities are now installed at all signalised intersections which adjoin a footpath or shared path on more than one side.

The signals consist of a red aspect displaying a standing figure above a green aspect displaying a green walking figure. Pedestrians must use the push button to activate the pedestrian crossing phase.

All parallel pedestrian crossings, crossings with an exclusive pedestrian phase and mid-block signalised pedestrian crossings use symbolic pedestrian signals.

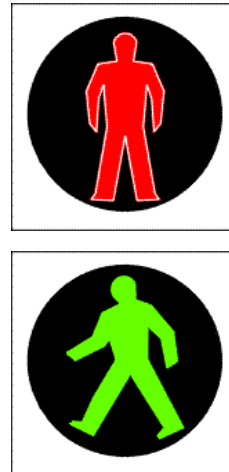

9.5.3 Circular Signals

Many existing signalised intersections have circular signals which are progressively being replaced with symbolic pedestrian signals.

Circular signals allow pedestrians to cross the road at any time when the green signal is displayed but do not provide any indication when they are about to change.

Intersections with circular signals do not protect pedestrians by preventing vehicle turning movements and rely on turning vehicles to give way to pedestrians crossing the road.



Beaufort Street and Aberdeen Street, Northbridge

9.5.4 Timings

The timings for symbolic pedestrian signals generally comprise:

- Walk period (green figure) - minimum 6 seconds
- A clearance period (red flashing figure) - based on a walking speed of 1.2 metres per second

At crossings with circular pedestrian signals, push buttons are generally provided which extend the normal green time to give pedestrians sufficient time to cross the road.



The cycle times at coordinated intersections are generally very long and pedestrians may have to wait over 2 minutes to cross the road. Long delays tend to frustrate pedestrians and often results in failure to observe the pedestrian signals, as shown in this example.

In busy pedestrian areas, consider introducing phasing to prioritise pedestrian movements and encourage more people to walk.



Wellington Street and William Street, Perth

9.5.5 Staged Crossings

Staged pedestrian crossings may be considered where a single crossing is impractical, such as at wide medians and complex intersections.

Staged crossings are usually offset so that it is clear that the crossings are separately controlled. Visors or louvres may be used to screen pedestrian signals that operate separately.



Karrinyup Road, Karrinyup

9.5.6 Left Turn Slip Lanes

Left turn slip lanes under Give Way control at signalised intersections may require crossing markings to ensure the safety of pedestrians. It should be noted that the Traffic Road Code gives priority to pedestrians crossing a slip lane at over turning vehicles. Zebra crossing markings reinforce this existing priority. The use of zebra crossings at only some slip lanes does create some confusion for motorists and pedestrians.

If more than one slip lane exists at an intersection and one of the slip lanes meets requirements for crossing markings to be installed, then all slip lanes should be provided with similar markings.

The zebra crossing treatment of free flowing slip lanes is similar to slip lanes under Give Way control.

Design Details

- Warrants for left turn slip lane pedestrian crossing markings are included in Section 9.2
- Refer to MRWA Standard Drawing 200531-0038 for zebra crossing markings at left turn slip lanes
- AGRD Part 4A, Section 10.6.3 provides further design discussion
- Locating the crossing one car length (6 m) from the vehicle holding line reduces conflict with queued cars



Pedestrians crossing slip lanes have priority over turning vehicles



Intersection of Marmion Avenue and Reid Highway, Carine

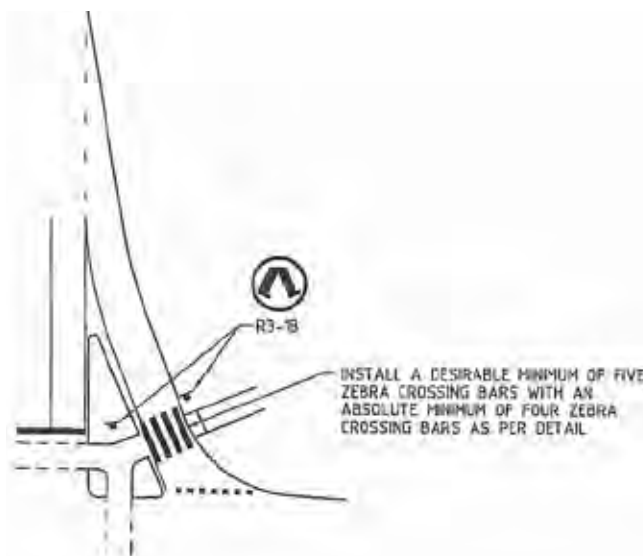

MRWA Standard Drawing 200531-0038 – Zebra Crossing at Slip Lanes for roads with speed limit \leq 60 km/hr

9.5.7 Parallel Pedestrian Crossings - No Protection by Vehicle Signals

Description

Pedestrian and vehicle signals turn green simultaneously allowing pedestrians to cross a signalised intersection in parallel with the traffic flow and at the same time.

Turning vehicles are still legally required to give way to pedestrians.

This form of phasing currently only occurs at signalised intersections without symbolic pedestrian signals (i.e. pedestrians cross on the green light for the parallel traffic flow).

Currently all parallel pedestrian crossings with symbolic pedestrian signals are either partially or fully protected by vehicle signals.



Scarborough Beach Road and Oxford Street,
Mt Hawthorn

Advantages

- Only delays to motorists are when turning vehicles give way to pedestrians

Disadvantages

- Some turning motorists may not give way to pedestrians
- Some pedestrians may hesitate, thereby encouraging vehicles to turn in front of them
- Some pedestrians assume that turning vehicles will give way and may not take adequate care

Preferred Locations

- Where turning traffic has clear sight lines to pedestrians
- Where turning volumes are low
- Where turning speeds are low
- Can only be implemented with the approval of the MRWA Executive Director for Road Network Services

Inappropriate Locations

- Intersections meeting the conditions for full protection by vehicle signals



Beaufort Street and Aberdeen Street,
Northbridge

9.5.8 Parallel Pedestrian Crossings - Partial Protection by Vehicle Signals

Description

Parallel pedestrian crossings partially protected by vehicle signals provide extra protection to pedestrians by giving them a head start to cross a signalised intersection before the parallel traffic flow commences.

Protection is provided at the start of the pedestrian phase by preventing vehicles turning with a red signal. At the end of the start period, the red signal is removed and turning vehicles are required to give way to pedestrians. The start period is generally 3 to 5 seconds.

Motorists are prevented from turning using:

- Red circular displays that delay the start of the green vehicle display
- Red left and right turn arrows

Advantages

- Minor delays to motorists

Disadvantages

- Some turning motorists may not give way to pedestrians after the red signal is removed
- Pedestrians assume that turning vehicles will give way after the start period and may not take adequate care
- Delays to through traffic and also turning traffic where separate turn lanes are not provided

Preferred Locations

- Refer to MRWA Guideline for Pedestrian Signals (D08#6040)
- Parallel crossings with partial protection are to be provided at:
 - All newly installed parallel pedestrian signal crossings for a period of 1 year, after which they will be assessed by the Manager Metropolitan Traffic Operations
- Locations where driver behaviour is considered by the Manager Metropolitan Traffic Operations to be unsafe without any pedestrian crossing protection

Inappropriate Locations

- Intersections where full protection by vehicle signals is preferred

Design Details

- The length of the pedestrian protection phase should be assessed on a site-by-site basis
- During the first 12 months of installation, turning traffic should be delayed by:
 - Where turning and through-traffic share a lane it should be a minimum of 3 secs and a maximum of the green walk period of 5 secs (whichever is greater)
 - Where a separate lane is provided for turning traffic it should be a minimum of 3 secs but can be extended longer than 5 seconds into the flashing red 'don't walk' phase if there is a low demand for turning traffic



William Street and St Georges Terrace, Perth



Barrack Street and St Georges Terrace, Perth

- Following the 12 month period and a review of the safe operation of the signals:
 - The traffic delay can be reduced to less than 3 secs or extended to a full pedestrian phase protection based on the pedestrian and traffic demand
 - any reduction in the length of the pedestrian protection is to be approved by the MRWA Executive Director for Road Network Services

9.5.9 Parallel Pedestrian Crossings - Full Protection by Vehicle Signals

Description

Fully protected parallel crossings allow pedestrians to cross a signalised intersection in parallel with the traffic flow under full protection by vehicle signals.

All vehicles are prohibited from turning during the full pedestrian phase using red left and right turn arrows.

Advantages

- Pedestrians using the crossing do not have to watch for turning vehicles (except where the turn movement is under give way control)
- Provides higher level of at-grade protection for all pedestrians (including the elderly or people with disability)

Disadvantages

- Delays to through traffic and also turning traffic where turn lanes are not provided

Preferred Locations

- Refer to MRWA Guideline for Pedestrian Signals (D08#6040)

Intersections where one or more of the following conditions are met:

- The sight distance between motorists and pedestrians is less than the stopping distance for typical vehicle speeds near the intersection
- The speed of traffic exceeds 50 km/h, or if in the CBD > 40 km/h
- The volumes of turning traffic exceeds 300 vehicles per hour
- The volume of heavy vehicles turning across the pedestrian footway exceeds 50 vehicles per hour for each of the same 4 hours of a normal weekday
- There has been more than one recorded vehicle versus pedestrian fatality in the previous twelve months.
- More than one lane of turning traffic is permitted with pedestrian movements, including both left and right turn lanes.
- There is significant use by children, the elderly or people with disability
- Traffic turning left out of a T-intersection

Inappropriate Locations

- Intersections that do not meet any of the conditions for preferred locations



Riverside Drive and Barrack Street, Perth



Albany Highway and Cecil Street

(signalising the slip lane provides full protection for pedestrians)

9.5.10 Exclusive Pedestrian Phase

Description

An exclusive pedestrian phase allows pedestrians to cross in all directions simultaneously in one movement with full protection from all traffic movements under signal control.

Crossings with an exclusive pedestrian phase may also incorporate supplementary parallel crossing sequences where the intersection geometry permits i.e. intersections of one-way roads.

The use of exclusive pedestrian phases is decreasing. Many intersections in the Perth CBD are currently being replaced with parallel pedestrian phases.



Wellington Street and William Street, Perth

Advantages

- Pedestrians using the crossing are fully protected
- Provides higher level of at-grade protection for all pedestrians (including the elderly and people with disability)

Disadvantages

- Significant delays to traffic movements
- Pedestrians wanting to make a parallel crossing must wait for the exclusive pedestrian phase (cannot cross one side road at a time)

Preferred Locations

- Refer to MRWA Guideline for Pedestrian Signals (D08#6040)

Intersections where **all** of the following conditions are met:

- None of the roads are a declared highway or main road
- The intersection is located in a central business area or major shopping area
- An equivalent or better alternative route is available for through traffic to avoid the intersection
- The existing signalised intersection is operating in a simple two traffic phase mode
- The pedestrian movements in all directions are significant and continuous:
 - This condition can be met where for each of any four hours of a normal weekday, all pedestrian movements in all directions exceed 200 persons per hour



William Street and Mounts Bay Road, Perth



William Street and Hay Street, Perth

9. Pedestrian Crossing Facilities

- Vehicular turning movements at the intersection are sufficiently high to impede reasonable pedestrian movement:
 - This condition can be met where for each of the same four hours of a normal week day, all vehicular turning movements in all directions exceed 400 vehicles per hour

Inappropriate Locations

- Intersections that do not meet all the conditions for preferred locations

9.6 Roundabouts

Objective

To outline measures to facilitate the safe use of roundabouts by pedestrians.

Key Points

The movement of pedestrians should be carefully considered in the planning and design of a roundabout.

Turning vehicles are not required to give way to pedestrians.

Good sight lines are required between pedestrians and motorists.

There are mixed views on the safety of roundabouts for pedestrians. Roundabouts do not provide priority for crossing pedestrians (unless zebra crossings are included). Many people consider roundabouts as being unsafe, due to the continual flow of traffic and lack of crossing opportunities. However, others consider roundabouts are at least as safe for pedestrians as other forms of intersection control.

One of the most important features impacting pedestrian safety is the speed of vehicles approaching the roundabout, which can be controlled through appropriate design. Where pedestrian volumes are high on each approach, dual lane roundabouts are not appropriate and a signalised intersections is a preferable treatment.

Small roundabouts found on local streets generally present few problems to pedestrians. Low traffic speeds and low traffic volumes assist with the ease of pedestrian movements.

Large multi-lane roundabouts can be difficult for pedestrians to cross due to the volume of traffic, longer crossing distances and higher vehicle speeds.

Liveable Neighbourhood guidelines recommend minimising the use of large roundabouts on arterial roads as they do not provide priority for pedestrians and cyclists to cross, with fewer gaps available in the traffic flow (compared to signalised intersections). Large roundabouts are only recommended on arterial roads with low volumes of pedestrians and cyclists, or as an interim treatment prior to a more significant road upgrade.

Advantages

- Splitter islands enable pedestrians to cross one direction of traffic at a time by staging the crossing
- Vehicle speeds are lower at a roundabout, thereby reducing the risk and severity of a collision with a pedestrian

Disadvantages

- Turning vehicles have right of way over pedestrians crossing the carriageway
- Pedestrians need to select appropriate gaps in the traffic stream



Churchill Street, Subiaco



Railway Road (connecting to Stubbs Terrace), Karrakatta

Design Details

- Refer to MRWA standard drawings 200331-197 and 200331-201
 - AGTM Part 6, Section 4 and AGRD Part 4B, Section 5.2 includes additional design information
- The following design issues should be considered to enhance pedestrian safety at roundabouts:
- Reduce vehicle approach speeds by providing adequate entry curvature or deflection on each approach
 - Ensure sight lines between pedestrians and motorists are not obstructed and sight distances are adequate for pedestrians to safely cross the carriageway
 - Ensure crossings are located within pedestrian desire lines, with kerb ramps orientated across the shortest crossing length (balanced with consideration of locating the crossing 1 car length from the vehicle stop line)
 - Design splitter islands which are as large as the site allows and accommodate the pedestrian demand
 - Prohibit parking on the approaches to roundabouts to provide clear visibility
 - Provide street lighting which illuminates the approaches as well as the circulating carriageway
 - Locate signs and vegetation so as not to obscure pedestrians, particularly children and people in wheelchairs
 - Landscaping in the central island should not block visibility between pedestrians and motorists
 - Consider including zebra crossing markings on single lane roundabouts where there is a large pedestrian demand

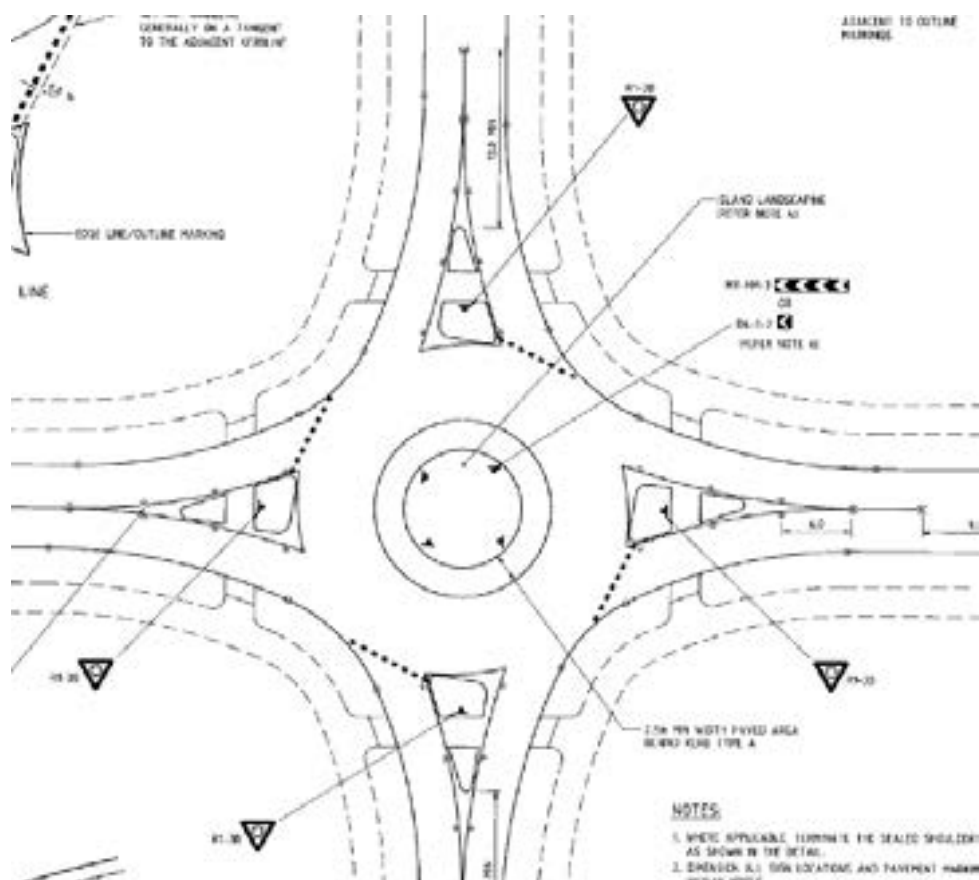

MRWA Standard Drawing 200331-197 Single Lane Roundabout Step 4 of 4

9. Pedestrian Crossing Facilities

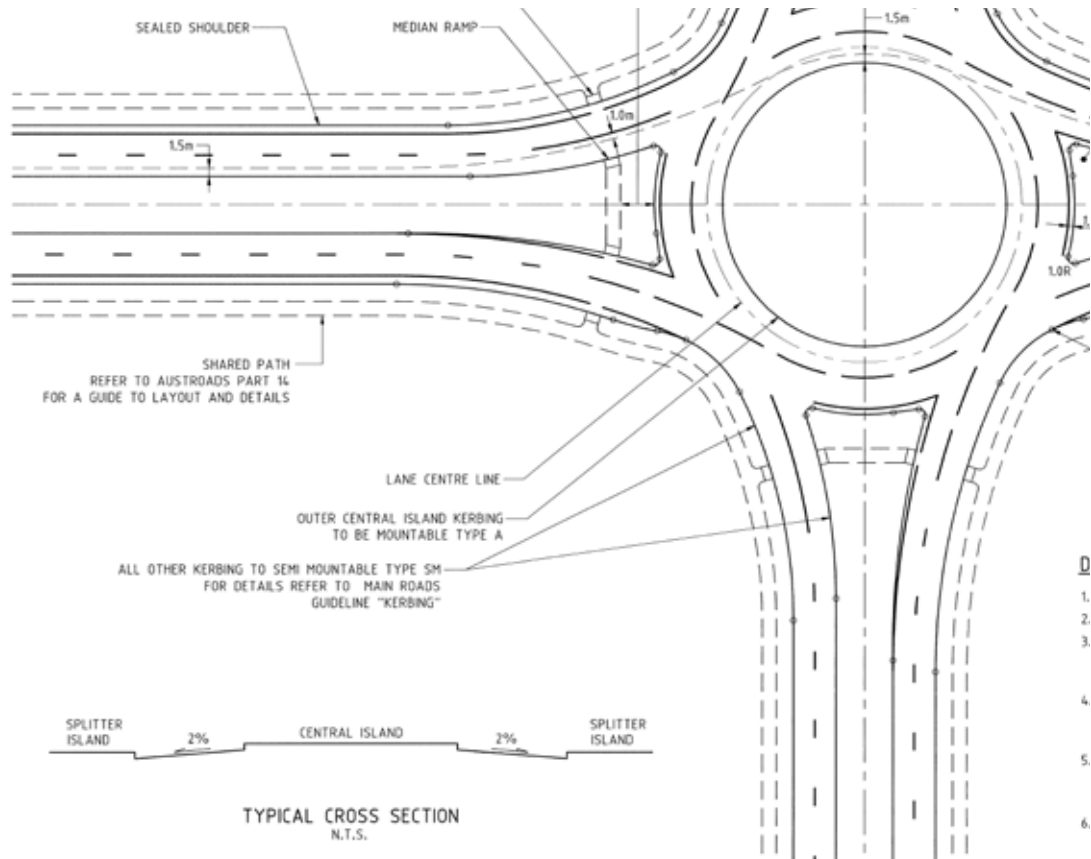

MRWA Standard Drawing 200331-201 Dual Lane Roundabout Step 3 of 4

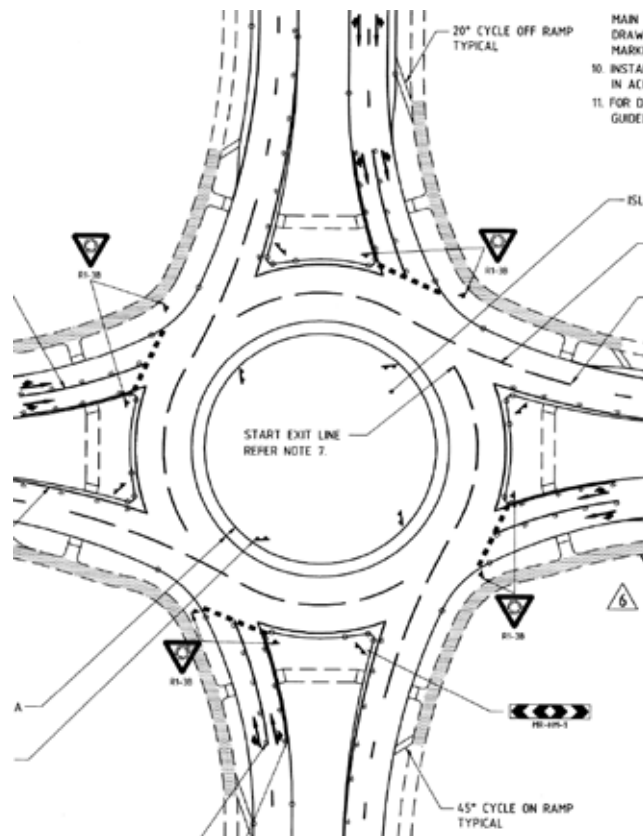

MRWA Standard Drawing 200331-202 Dual Lane Roundabout Step 4 of 4

Complementary Treatments

Kerb ramps and gaps are generally located at least one car length (6 m) from the entry holding line. This set-back distance enables a pedestrian to walk behind a stopped vehicle and reduces the chance of pedestrians not being seen by drivers who are seeking a gap in the circulating traffic. A similar distance is provided on the exit from the roundabout.

A common treatment for medium to large roundabouts is to construct a peripheral shared path around the roundabout, with connections to/from shoulders on the approach roads (see left side of picture).

The pedestrian ramps and splitter island in the median are set back. The Roundabout also employs pre-deflection on the approaches to the roundabout to slow down vehicles.



Railway Road, Karrakatta

Inclusion of Zebra Crossings

Zebra crossings should be considered at roundabouts where:

- Pedestrian volumes are high
- The speed environment is not greater than 40 km/h
- There is a high proportion of children, elderly or people with disability wanting to cross the road
- Pedestrians are experiencing difficulty in crossing and are being excessively delayed

MRWA are considering developing warrants for the installation of zebra crossings at roundabouts to provide clear guidance on appropriate sites.

Where practical, the crossings should be located 6-12m back from the holding line on both the entry and exit carriageways. Locating the crossings at the holding line will reduce traffic efficiency, but this may be appropriate in slow speed activity centres.

Zebra crossings have been used in the central island. In this example, the crossing is within a busy shopping centre where there is a heavy pedestrian movement and vehicle speeds are low.



Queen Street and Cantonment Street, Fremantle



Progress Street and Bishop Street, Morley

Alternative Treatments

Traffic signals may be more appropriate where pedestrian and traffic volumes are high, particularly if a significant proportion of the pedestrians are children, elderly or people with disability.

Where pedestrian volumes are only high on one leg of the roundabout, it may be appropriate to provide a signalised pedestrian crossing set back 12 – 24 metres from the holding lines. AGRD Part 4B Section 5.2 outlines the issues which should be considered for this design approach.



The Causeway, Perth

9.7 Grade Separated Crossings

Objective

To illustrate structures that eliminate conflict between pedestrians and vehicles by grade separating pedestrians from vehicular traffic.

Key Points

Location of the structure is important to maximise the benefits of this expensive treatment.

Grade separation of a pedestrian crossing from a roadway can be achieved using either a bridge or an underpass. This type of crossing provides the highest level of protection for pedestrians and minimises the disruption to road traffic.

Grade separated crossings are rarely provided except at freeways and other limited access roads such as Roe, Tonkin and Reid Highways which carry large traffic volumes at high speeds. Crossings have been provided elsewhere but generally as a result of strong community representation. The main reasons for their limited adoption are because of the high capital cost and general poor patronage due to the additional crossing length and level difference.

Fencing is often used on the approaches to a pedestrian bridge or underpass to prevent pedestrians taking the shorter path across the traffic instead of the longer, but safer, route using the facility.

The choice over whether to use a bridge or an underpass depends upon the particular location. A bridge can be visually obtrusive and generally requires longer ramp sections to clear the road. The level difference is less for an underpass, however personal security is reduced, lighting costs are higher and vandalism is more common.

Designing Out Crime principles should be incorporated into the design process, particularly for underpasses (also known as Crime Prevention Through Environmental Design or CPTED).



Footbridge at Roe Highway, Langford



Underpass at Plain Street, East Perth

Advantages

- The safest type of pedestrian crossing facility
- No delays to vehicular traffic

Disadvantages

- High capital cost
- Level difference can cause problems for the elderly and persons with a mobility impairment
- Generally poorly patronised (except at a school or where fencing is used) due to the level difference and longer walking distance (particularly at a pedestrian bridge) and reduced perception of personal safety
- Many pedestrians prefer to cross at grade, often without using any crossing facility
- A bridge can be visually intrusive and result in privacy concerns from nearby residences
- An underpass has reduced personal security, high lighting cost and is prone to vandalism

Overpasses are often the only way to cross busy highways - such as Roe Highway - Cameron Street Bridge.

Usage can be increased if it links well to principal shared paths and links to community facilities/destinations for both pedestrians and bike riders.

Preferred Locations:

- Across freeways and other high standard roads
- Across major non-freeway roads where alternative pedestrian crossing facilities are not feasible
- Across railway lines

Inappropriate Locations

- Where alternative pedestrian crossing treatments are suitable



Underpass at Haydn Buntun Drive, Subiaco



Barrier screen on Cameron Street Footbridge

Note: This bridge is used by many bike riders as it links in with a Principal Shared Path along Roe Highway.



Pedestrian overpass at Carousel Shopping Centre, Cannington

Design Details

- AGTM Part 6 Table 8.1 and AGRD Part 4C Section 4.4 include a brief discussion of considerations for grade separated crossings
- AS5100.1 – 2004 Clause 9.1 and Clause 12 include design information for pedestrian bridges
- Bridges and underpasses must be accessible for pedestrians with disability:
 - Information on ramp gradients, TGSi and balustrades is included in Section 7.6 and 7.9
- To encourage patronage of grade separated facilities:
 - The maximum change in level for overpasses should be about 6.5 m
 - The maximum change in level for underpasses should be about 3.5 m, with pedestrians able to see along the length of the underpass
- Overhead clearance within the structure must allow for safe pedestrian and cyclist passage:
- Minimum clearance of 2.5 m for routes used by pedestrians and cyclists (Refer to Section 7.4)

9.8 Railway Crossings

Objective

To outline pedestrian crossing facilities at railway crossings.

Key Points

The type of pedestrian crossing depends on the location of the railway and the number of pedestrians using the crossing.

Good sight lines are required.

Pedestrian railway crossings comprise:

- Grade separation
 - Bridges
 - Underpasses
- at-grade
 - Pedestrian crossings beside level crossings
 - Pedestrian crossings at stations
 - Pedestrian crossings remote of level crossings and stations
 - Unauthorised crossings

The remainder of this section only deals with formal at-grade pedestrian crossings.

The main types of such crossings are:

- Pedestrian mazes:
 - These are used on the non-electrified freight lines where necessary
- Lockable gates:
 - These are used on the electrified urban lines and on some freight lines in built-up areas

AS1742.7 – 2007 Appendix F, Figures F1 – F7, provide a number of layout options for pedestrian (and cyclist) mazes and controlled gate railway crossings. All new or upgraded crossings should be designed in consultation with PTA.

Design criteria to consider when assessing the appropriate crossing control method (maze or lockable gates) is included in AS1742.7 – 2007, Section 6.

This includes design information on:

- Hierarchy of Control (Section 6.2)
- Sight distance and footpath access requirements (Section 6.3.1 – 6.3.3)
- Design of mazes and enclosures (Section 6.3.4 – 6.3.5)
- Design of pedestrian holding markings, warning signs and signals (Section 6.4 – 6.5)



Dorothy Street, Gosnells

9.8.1 Pedestrian Mazes

Pedestrian mazes are designed to orientate pedestrians so that they face oncoming trains before crossing the railway. This is achieved by forcing pedestrians to make at least one 180 degree turn while passing through the maze.

Additional fencing may be required to prevent pedestrians skirting around the maze.

This diagram shows a typical arrangement of a pedestrian maze at a railway level crossing.

The description accompanying this figure in AS742.7-2007 indicates the maze dimensions provide adequate manoeuvring space for a pedestrian in a wheelchair or mobility scooter. In addition to providing an adequate width on the access path, the path design across the railway tracks should ensure wheelchairs and mobility scooters do not become stuck. Consult with the disability advocacy groups if in doubt.

The design of the maze should account for buildings or other obstructions along the side of the railway that could prevent pedestrians from seeing an approaching train.

In this example, the maze should have been arranged so that pedestrians face the direction of the obstruction when closest to the rail line.

For detailed drawings and measurements refer to AS1742.7-2007-Layout example for Pedestrian Maze, Appendix F (Figure F1)



Prout Way, Spearwood



Visibility obscured by Storage Container

9.8.2 Lockable Gates

Lockable gates are remotely controlled to prevent pedestrians from crossing the railway before and during the arrival of a train.

A gate is provided to allow access from the railway crossing if a pedestrian is caught on the crossing.

Lockable crossings are equipped with red flashing pedestrian lights and audible electronic alarms.



Dorothy Street, Gosnells

10. Pedestrian Guidance Measures

In this Section

10.1 Lighting

- 10.1.1 Critical Areas of illumination
- 10.1.2 Pedestrian Crossings
- 10.1.3 Pedestrian and Cyclist Pathways
- 10.1.4 Underpasses and Tunnels
- 10.1.5 Location of Lights

10.2 Directional, Service and Tourist Signs

- 10.2.1 Location
- 10.2.2 Direction Signs
- 10.2.3 Visibility
- 10.2.4 Legibility
- 10.2.5 Font
- 10.2.6 Colour Contrast
- 10.2.7 Glare and Reflective Surfaces
- 10.2.8 Pavement Markings

10.3 Pedestrian Warning Signs

10.1 Lighting

Objective

To illustrate the importance of providing lighting in locations where pedestrians are required to make decisions regarding their safety.

Key Points

Provide increased levels of lighting at focal points and hazardous locations.

Locate light poles off the path of travel.

Lighting should be positioned to avoid glare.

Lighting is to be in accordance with the requirements of public lighting use as outlined in MRWA Lighting Design Guideline for Roadway and Public Spaces (D09#291515) and the AS 1158 series. It is to provide a lighted environment to assist pedestrians to orient themselves, detect potential hazards and discourage crime.

Performance and design requirements of lighting are based on an assessment of degree of activity, risk of crime and the required aesthetic appeal.

Where lighting is designed primarily for the vehicular roadway, the positioning of lights should be checked to ensure that they not only meet the minimum code requirements for the carriageway, but also provide above average levels at locations where pedestrians are likely to require illumination.



Shenton Park Train Station

10.1.1 Critical Areas of illumination

Illumination level requirements are detailed in AS/NZS1158.1.1 – 2005 (vehicular traffic lighting), AS/NZS1158.3.1 – 2005 (lighting for pedestrian areas), AS/NZS1158.4 – 2009 (supplementary lighting for pedestrian crossings) and AS1680.2.1 – 2008 (indoor carparks, internal stairs, lifts and ramps).

Pedestrian areas which require particular lighting include focal points such as:

- Steps
- Stairs
- Ramps
- Zebra crossings and refuges
- Traffic signals and roundabouts
- Traffic control devices such as speed humps in car parks
- Outside drinking establishments
- Bus stops
- Entrances to parks
- Entrances to community facilities
- Pedestrian accessways (PAWS), underpasses and overpasses

Any lighting provided must be designed such that if one source fails, a second will continue to provide at least some light.



Shenton Park Train Station

10.1.2 Pedestrian Crossings

AS/NZS1158.4 – 2009 details lighting of pedestrian crossings.

The main aims of lighting pedestrian crossings are to:

- Give motorists advance warning of the crossing
- Enhance pedestrian conspicuity

Lighting levels for pedestrian crossings at railway crossings should be consistent with lighting on the adjacent path to avoid glare or sudden changes in lighting levels. This reduces distraction from pedestrian warning signals at railway crossing barriers or the light from approaching trains.



Preston Street, South Perth

10.1.3 Pedestrian and Cyclist Pathways

Lighting requirements for pedestrian and cyclist pathways are outlined in MRWA Lighting Design Guideline for Roadway and Public Spaces (based on the AS/NZS1158.3.1 – 2005 requirements).

It should be noted that these lighting levels are not always appropriate for local roads. Lighting on local roads should minimise obtrusive light into the adjacent houses, minimise energy use and provide safe access for pedestrians. Check Local Government lighting practices for paths managed by Councils.

Requirements for major shared paths managed by Main Roads include:

- All pedestrian lighting design and installation shall be High Pressure Sodium (HPS) lamps
- Point horizontal and vertical illuminance is to be a minimum average of 5 lux
- At locations of potential conflict and high pedestrian usage such as intersection of paths and rail stations, the point horizontal and vertical illuminance is to be a minimum of 20 lux (although this is not always practical to achieve)

MRWA Standard Drawings 0448-3007 and 0448-3008 provide details on typical lighting layout for Principal Shared Paths:

- Lighting poles should desirably be setback between 0.8 m – 1 m from the edge of path (0.5 m absolute minimum for cyclist paths)
- The pedestrian lights are typically mounted at a height of 7 m, with the outreach arm length between 0 to 1.5 m

For footpaths along local roads, lights mounted at a height of 5 - 6.5 m may be more appropriate, and will reduce light spill into adjacent properties.



Tony de Scerni Pathway, Mount Lawley



David Carr Park, Perth Esplanade

10.1.4 Underpasses and Tunnels

AS/NZS1158.3.1 – 2005 includes the lighting requirements for pedestrian connections such as underpasses and tunnels. Lighting is to be provided at a P10 level.

If longer than 20 m, lighting will need to be provided both day and night. Illumination levels should be higher during the day as those with low vision and seniors may have problems adjusting to varying light intensities and contrasts.

The walls of a subway are recommended to be finished with a light colour to facilitate inter-reflection of light within the space.

Design and performance requirements of the underpass or tunnel are dependent on the structural and traffic characteristics of the infrastructure.



**David Carr Park,
Perth Esplanade**

10.1.5 Location of Lights

Attention should be given to placing lights to avoid glare. In general, this means that lights with good light control should be used and mounted out of the normal field of vision of people looking at the ground in front of them.

The location of poles must not obstruct pedestrian footpaths. Refer to the minimum pedestrian through-route widths outlined in Section 7.1. For shared cyclist and pedestrian paths, a desirable clearance of 0.8 m -1 m should be provided from the edge of the path to lighting poles (absolute minimum of 0.5 m).

The relationship between signs and lighting is important. Aim to illuminate all critical information without reflection or glare.



Station Street, Subiaco

Note: The top photo illustrates the inappropriate placement of a light pole in the centre of a path. The second photo illustrates a light pole placed correctly outside of the pedestrian through-route.



Vincent Street, Mount Lawley

10.2 Directional, Service and Tourist Signs

Objective

To illustrate some important considerations when providing information to pedestrians via pathway signage.

Key Points

Must not intrude into the clear continuous path of travel.

Needs to be appropriately oriented.

Needs to be visible, legible and understandable.

Direction and guide signs provide information to pedestrians to assist them identify and locate a particular amenity or facility, or provide information on the use of a facility (such as the shared path sign below).

In busy activity centres, maps identifying key destinations can assist with improving the walkability of an area, particularly where there are large numbers of tourists.



Albany Highway, Gosnells, Wayfinding Signage

10.2.1 Location

Signs should be located next to the pathway and not within its space, to allow for room where pedestrians can congregate in front of it without blocking the path.

Signs should face the oncoming pedestrian traffic.



10.2.2 Direction Signs

Depending on the positioning of any given sign, care will need to be taken to ensure that the use of any directional information or symbols make sense in the immediate environment.

Direction signs would be required at changes in direction.

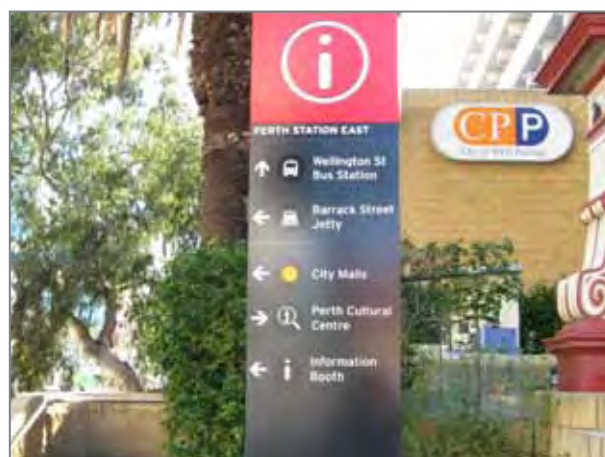

Barrack Street, Perth Train Station

10.2.3 Visibility

AS1428.2 – 1992 Clause 17 includes information on sign height, lettering height and illumination. AS1428.1 – 2009 Clause 8 provides additional information on braille and tactile signage. The Access Resource Kit (produced by the DSC) provides a checklist on the appropriate design and placement of signs to meet disability access requirements.

To accommodate children, people in wheelchairs and people standing, the most appropriate height is in the range of 1.2 m to 1.6 m, however where this space is unavailable the absolute minimum height is 1 m.

Where the sign can be temporarily obscured e.g. by crowds the height should be a minimum of 2 m.

If a sign has to be placed above a pathway then it should be cantilevered above a height of 2.5 m.

In some situations signs will be mounted on a wall immediately adjacent to a walkway. If the sign is mounted flush to the wall it should be at a height range of 1 m to 1.6 m.

If the sign is mounted such that it protrudes into the pedestrian space, it must be at a height above 2.5 m.



Gosnells Train Station
Pedestrian Rail Crossing showing signage at correct height



Booragoon Bus Station
Note: The bottom photo shows that the sign should be mounted within the preferred range.

10.2.4 Legibility

Use of both plain English and symbols is encouraged and will greatly enhance access to the information for those with cognitive disability. The use of recognised international symbols is preferred, complying with the international standard in style, colour and layout as detailed in AS1428.1 – 2009.



Booragoon Bus Station

10.2.5 Font

Simple or Sanserif fonts, such as Arial or Helvetica, should be used.

Font size is dependent on the required viewing distance and must be in accordance with AS 1428.2 – 1992 Clause 17.

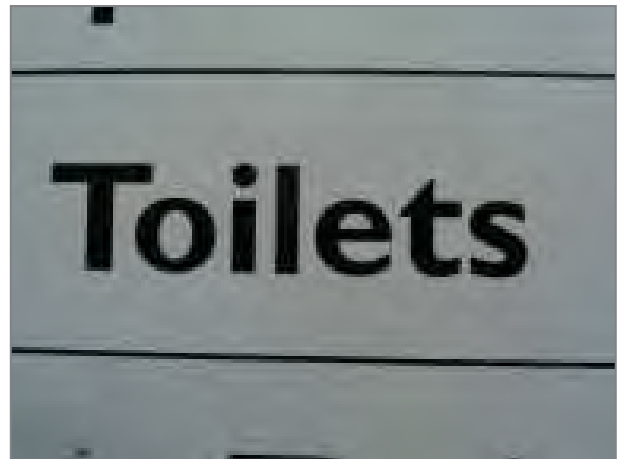

Booragoon Bus Station

10.2.6 Colour Contrast

Provide good colour contrast (at least a 30 percent luminance factor in accordance with AS1428.2 – 1992) between the text and its background and between the sign itself and its surrounding surface or background. Black text on white background provides a good colour contrast. Avoid colours that clash, e.g. Green text on a red background.

The background behind the sign, such as a wall, should provide sufficient contrast to the sign. Otherwise, the background to the sign should be increased in size.



Booragoon Bus Station

10.2.7 Glare and Reflective Surfaces

Surfaces that are reflective give off a lot of glare which can limit visibility and may cause discomfort to some people with certain vision conditions. Avoid covering signage with glass, clear Perspex or like see through materials which might give off a lot of glare or reflection.



Westralia Square Building

10.2.8 Pavement Markings

Pavement markings may be used to indicate shared or separated pedestrian and cyclist facilities.

They should also be clearly visible and effective for all likely conditions, e.g. day, night, rain, fog, rising or setting sun, oncoming headlights, light coloured pavement surface, and poor lighting. Pavement markings must be installed to the appropriate standard to provide slip resistance (otherwise can become a hazard for path users in wet conditions).

Pavement markings need to be slip resistant and maintained to a high standard, with redundant markings removed.



Shared path, Claremont Train Station

10.3 Pedestrian Warning Signs

Objective

To illustrate the use of warning signs to warn motorists of the presence of pedestrians.

Key Points

Signs must be located in advance of the crossing to enable motorists to take appropriate action.

Pedestrian warning signs are used to convey information to motorists of approaching pedestrian activity and crossings.

They must be placed sufficiently in advance of the crossing to provide adequate time for motorists to react and take any cautionary action that may be necessary. MRWA standard drawings, AGRD Part 4 Section 8.2.2 and AS 1742.10 – 2009 provide information on the placement of warning signs in advance of pedestrian crossings.

The design of the signs must comply with Australian Standards AS 1742.10 – 2009 and MRWA requirements.

New Pedestrian warning signs must now be manufactured with fluorescent green / yellow sheeting. The only exception is the Children warning sign (MR-WDP-3B) which is placed in front of children's crossings, and has fluorescent orange sheeting. Existing non-fluorescent signs are to be progressively upgraded.

Lighting of signs must be adequate for both day and night use.

The Signals Ahead (W3-3B) sign is used in advance of signalised intersection and mid-block pedestrian crossings. A supplementary Crossing Ahead (W8-22B) sign is used when the sign is placed in advance of a mid-block pedestrian crossing. This sign does not require fluorescent sheeting as it is a standard traffic sign rather than a specific pedestrian warning sign.

MRWA Standard Drawing 200431-0116 specifies W3-3B and W8-22B size signs to be used in advance of mid-block puffin and pelican crossings.



Signals Ahead (W3-3) with supplementary Crossing Ahead (W8-22) sign

10. Pedestrian Guidance Measures

The Pedestrian Crossing Ahead (W6-2) sign is used in advance of zebra crossings.

MRWA Standard Drawing 200331-164 specifies a R3-1B size sign to be used in advance of zebra crossings.

The Pedestrians (W6-1B) sign is used to warn of the presence of pedestrians crossing the road other than at a controlled pedestrian facility. Supplementary signs such as School (W8-14), Aged (W8-18) and Blind (W8-19) can be used in conjunction with this sign if appropriate.

Where a pedestrian refuge island is located on a road with a speed of 70 km/h or greater, a Pedestrian warning sign (W6-1B) and Refuge Island supplementary sign (W8-25B) must be placed in advance of the crossing as per MRWA Standard Drawing 200331-139 and 200331-140.

The use of a fluorescent orange Children (MR-WDP-3B) sign is only permitted to be used on the approach to an approved guard controlled children's crossing (as outlined in MRWA Standard Drawing 9120-174 and 9531-2169). A School supplementary sign (W8-14B) is to be used where the controlled children's crossing is located outside of a school speed zone. Flags are added to this sign, as in this example, to indicate that the children's crossing is in operation.

In other locations where there is an unexpected presence of children crossing, the fluorescent yellow / green version of this Children warning (W6-3B) sign may be used as outlined in AS1742.10-2009.



Pedestrian Crossing Ahead (W6-2)



Pedestrians (W6-1)



Children warning sign (MR-WDP-3B) with supplementary School sign (W8-14B)

11. Speed and Environmental Changes

In this Section

11.1 School Speed Zones

- 11.1.1 Speed Limits
- 11.1.2 Times of Operation
- 11.1.3 Selection Criteria
- 11.1.4 Length of School Zone
- 11.1.5 Signs and Pavement Markings

11.2 Variable Speed Zones

- 11.2.1 Design and Approval
- 11.2.2 Examples

11.3 Shared Zones

- 11.3.1 Criteria
- 11.3.2 Roadways and Parking
- 11.3.3 Traffic Calming in Shared Zones
- 11.3.4 Signs

11.4 Traffic Calming

- 11.4.1 Traffic Management in Activity Centres
- 11.4.2 Physical and Regulatory Techniques
- 11.4.3 Precautions

11.1 School Speed Zones

Objective

To illustrate the use of school zones to improve the safety of children walking to and from school.

Key Points

Vehicle speeds are reduced through school zones during school starting and finishing times.

School zones contribute to the safety of school children by lowering the speed limit and raising motorists' awareness of the presence of school children when driving near a school.

The school zone sign is a regulatory device that requires motorists to drive at a reduced speed during school days at nominated times. The times of the reduced speed limit are restricted to school starting and finishing times to coincide with those times when there is activity along the school frontage and students will be on or near the road.

All pre-primary, primary and secondary schools should be regarded as eligible for a school zone provided the school environment is compatible with the selection criteria. MRWA Speed Zoning Policy, Application and Technical Guidelines (particularly Part C, Section 2.3.3) provide information on school zone implementation.

AGTM Part 8 Local Area Traffic Management Section 7.5.8 includes general information on school zones.



Hamersley Road, Subiaco

11.1.1 Speed Limits

The appropriate school zone speed limits are as follows:

Speed limit applying outside of school hours (km/h)	School zone speed limit (km/h)
50, 60, 70	40
80, 90	60

There are two school zone speed limits to ensure motorists do not experience a speed decrease of more than 30 km/h over a short section of road.



Smyth Road, Nedlands

11.1.2 Times of Operation

To ensure state-wide uniformity the following times of operation are used on School Zone signs. These standard times allow for the variations in individual school start and finish times.

Area	AM	PM
Northern Region	7.30 AM - 9.00 AM	2.00 PM - 3.30 PM
Carnarvon Area	7.30 AM - 9.00 AM	2.00 PM - 4.00 PM
All other areas of WA	7.30 AM - 9.00 AM	2.30 PM - 4.00 PM

All times of operation within a town or city shall be consistent. Times may vary marginally between towns.



Note: that the above sign (without the supplementary orange cap) applies to roads which do not directly front the school or for repeater signs through the zone

11.1.3 Selection Criteria

Preferred Locations

Generally, all sealed urban and rural school frontage roads are suitable for the provision of a school zone.

Inappropriate Locations

School zones are not (unless there are exceptional circumstances) to be installed on:

- Freeways
- Control of Access Highways
- Generally not on distributor roads where grade separated children / pedestrian crossing facilities have been provided (some exceptions – such as Beaufort Street, Mt Lawley)
- Six-lane roads
- Roads within an area speed zone equal or less than the proposed school zone
- Two lane roads with the carriageway width greater than 10 m (Kerb extensions, medians or pedestrian refuge islands should be considered to reduce the width to less than 10 m)
- Roads where direct access is restricted for children via physical barriers such as fencing, walls, embankments etc



School Zones are not desirable but may be eligible for consideration on:

- Single carriageway road with a seal width less than 5.5 m wide
- Four-lane and two-lane undivided roads carrying over 15,000 vpd
- Four-lane and two-lane divided roads carrying over 20,000 vpd
- Four-lane roads with clearways

Alternative Options

Where any of these types of road fronts the school, an investigation should be undertaken to:

- Relocate pedestrian access and activity to another frontage
- Improve the management of traffic and pedestrians by, for example, installing guardrail, safety fence, additional children and school warning signs and improving existing pedestrian facilities (consider grade separated crossings)

11.1.4 Length of School Zone

Coverage

School zones should extend at least the full length of the school frontage and generally about a further 50m beyond the school frontage to effectively cover children crossing in the vicinity of the school. The proposed School Zone sections shall be extended to include children’s crossings, zebra crossings, pelican crossings or pedestrian refuges in the immediate proximity of the school.

Minimum Length

The minimum length of a school zone along the main school frontage should generally be not less than:

- 200 metres – where the school zone speed limit is 40 km/h
- 300 metres – where the school zone speed limit is 60 km/h

Actual Length

The actual lengths of school zones should be determined from the needs of the individual school, having regard for:

- The type of road
- Traffic volume
- Traffic speed
- Visibility
- Road conditions

Other Considerations

Where possible, the school zone should be installed such that the point at which most students enter and leave the school is centred within the school zone.

The existence and location of school crossing facilities (such as children’s crossings, zebra crossings, or pedestrian refuges) should be taken into account in determining the length of the school zone. The school zone should extend over a length sufficient to include any such facilities in the immediate proximity of the school.

Where two schools are nearby, both independently satisfying the selection criteria, one continuous school zone serving both schools may be appropriate.



Smyth Road, Nedlands



Walking to school in the rain

11.1.5 Signs and Pavement Markings

Sign Specifications

MRWA Speed Zone Technical Guidelines (D10#92683) Part 2.2.3 provides details on the sign specification for different zones.

Start of School Zone

- The start of a school zone is defined by a 'school zone' sign indicating the reduced speed limit and the times and days of operation
- A supplementary orange cap (MR-RS-17) is included on signs at the start of the zone on roads which front the school
- The school zone only operates during the times shown on the sign during school days or other specified days
- School zone signs may be repeated to reassure drivers that they are still within the school zone if the lengths of the frontage roads are greater than 300 m

End of School Zone

- The 'end school zone' sign is used to identify the end of a school zone
- Where the speed limit beyond the school zone is subject to a speed zone greater or less than the general built-up area or rural limit, the end school zone sign is to be installed in conjunction with the appropriate speed restriction sign



School Zone Sign placed at the start of the zone on roads fronting the school
(MR-RS-15B)

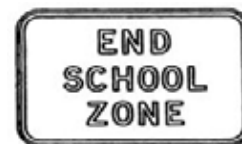

End School Zone Sign
(R4-9)



End School Zone Sign in a Speed Zoned Area
(Sign No's)

Pavement Markings

Pavement markings, comprising a yellow rectangle with black numerals are appropriate on roads where

- Electronic speed limit signs are not provided
- The road has a speed limit greater than the Built Up Area 50 km/h default speed limit outside of the School Zone times
- The road is distributor road status and has an annual average daily traffic volume greater than 5,000 vehicles per day (applicable to Perth Metropolitan Region, City of Bunbury and City of Mandurah) or the road is Distributor road status (applicable in all other rural locations)

The markings are only installed in the following locations:

- On the main entry points to the school zone
- Adjacent to the first school speed zone sign
- On a straight section of road outside vehicle swept turning path at intersections



School Zone '40' Pavement Marking



School Zone '40' and '60' Pavement Markings

MRWA Standard Drawing
200631-0022 and 200731-0037

Electronic School Zone Signs

Electronic School Zone signs shall only be considered on the main school frontage road where the school has direct access to a road with a speed limit > 60 km/h. Provision of Electronic School Zone signs is subject to budgetary constraints and shall be prioritised as follows:

1. Four-lane undivided carriageway ≥ 60 km/h
2. Two-lane undivided carriageway > 60 km/h
3. Four-lane divided carriageway or with pedestrian refuge island > 60 km/h
4. Two-lane divided carriageway or with pedestrian refuge island > 60 km/h

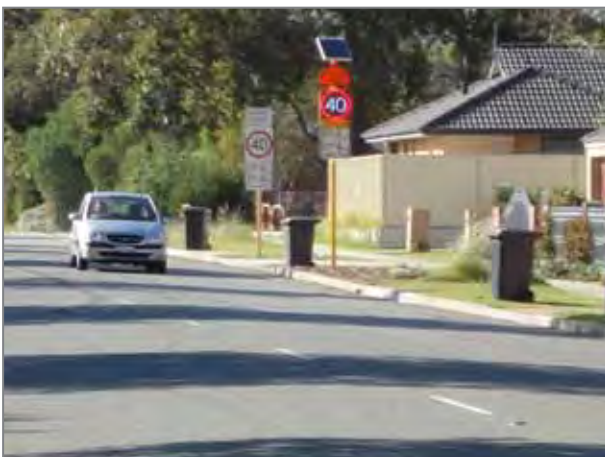

Gosnells Primary School, Hicks Street
Electronic School Zone Sign 7.30-9AM and 2.30-4PM on school days



Gosnells Primary School, Hicks Street
Electronic School Zone Sign out of school times

11.2 Variable Speed Zones

Objective

To identify the appropriate use of variable speed zones.

Key Points

Electronic signs can be used to implement a lower speed limit during peak periods of pedestrian activity.

Variable speed limits can be applied to distributor roads which experience a high level of pedestrian activity during the day, compared to a predominantly through-traffic function at night.

School speed zones are one example of variable speed limits, but more recently variable speeds have been applied to distributor roads which also function as 'Main Street' developments.

One of the main objectives for reducing the daytime and evening speed along these roads is to improve pedestrian safety. Research has shown even small differences in vehicle speeds can result in large differences in death and serious injury risk. Reductions of 10 km/h in average vehicle speeds over the full length of a treatment survey site were associated with an estimated reduction of 2 - 3 percent in fatal pedestrian crashes and 15 percent reduction of serious injury pedestrian crashes (Monash University, 2005).

Even without the speed reduction, traffic flows through 'Main Street' developments are interrupted by the pedestrian activity and on-street short term parking demand. Implementing a reduced speed limit reinforces the appropriate traffic speed through the busy activity centre, and acts as an additional warning to motorists to expect to slow down for pedestrians.



Beaufort Street, Mount Lawley

11.2.1 Design and Approval

The existing sites are located on primary distributor roads which are managed by MRWA. The introduction of variable speed limits at these sites was a joint initiative of MRWA and the relevant Local Government authorities.

Design and approval for the electronic signs and reduced speed limit is the responsibility of MRWA. The electronic signs are powered by solar energy and installed on standalone poles.



Variable Speed Limit Sign
(MR-RS-23)

11.2.2 Examples

Beaufort Street, Mt Lawley:

- The variable speed limit applies to the section of Beaufort Street between Lincoln Street and Walcott Street where there is a significant concentration of shops, cafes, hotels and local businesses
- Electronic signs reduce the speed to 40 km/h between 7.30 am to 10.00 pm, extending to 1.00 am on Friday and Saturday nights
- Outside of these times, the electronic signs apply the previous 60 km/h speed limit



Beaufort Street, Mt Lawley

Great Eastern Highway, Mundaring

- The Mundaring town centre is located along the Great Eastern Highway corridor, carrying regional and interstate traffic
- To improve the safety of pedestrians accessing shops and businesses on either side of the highway, the speed is reduced to 50 km/h between 7.30 am to 10.00 pm each day
- Outside of these times, the electronic signs reflect the previous 60 km/h speed limit



Great Eastern Highway, Mundaring

South Western Highway, Byford

- The Byford town centre is located along the South Western Highway corridor, carrying a large volume of regional traffic
- To improve the safety of pedestrians accessing shops and businesses on either side of the highway, the speed is reduced to 50 km/h between 7.30 am to 10.00 pm each day
- Outside of these times, the electronic signs reflect the previous 60 km/h speed limit

11.3 Shared Zones

Objective

To illustrate the use of zones where pedestrians and vehicles share the same space.

Key Points

Motorists are required to give way to pedestrians in a shared zone.

The built form of the road must reflect and encourage motorists to drive below the 10 km/h speed limit.

A shared zone is an area utilised by both pedestrians and vehicular traffic in which vehicles must give way to pedestrians at all times, and where the street environment has been adapted for very low speed vehicles.

Shared zones attempt to change the image and character of a street so that drivers are made aware that they are entering a street environment with driving conditions that are quite different to other more common situations.

AGTM Part 7 Activity Centres provides information and examples of shared zones in busy commercial, tourist and heritage areas where there is a desire to create a pedestrianised place.



Murray Street Mall, Perth

AGTM Part 8 Local Area Traffic Management Section 7.5.7 provides information on the application of shared zones on local streets. For roads controlled by MRWA, refer to AS1742.4-2008, Section 3.2.6.

Pedestrians have legal right-of-way over all other road users in a shared zone and this should be reflected by the signing, layout and construction:

- The extent of the zone is defined by signs displaying the change in speed limit at the entrances and exits
- A 10 km/h traffic speed limit has been found to be compatible with pedestrian movement
- Speed reduction techniques are often used within the zone to reinforce the low speed environment, e.g. the use of different coloured and / or textured pavement surfaces
- Signs should be installed in accordance with AS1742.4 – 2008, Section 3.2.6

Examples where shared zones are applied in WA are Hay and Murray Street malls, Perth. However, there are a number of other streets and areas that may satisfy the criteria.

11.3.1 Criteria

Shared Zones can be located within a central business district, a dedicated tourist area or a heritage area.

These are assessed individually based on the following criteria:

- Traffic volumes shall be less than 300 vehicles per day after the shared zone is installed
- Pedestrian movements shall predominate over vehicular movements
- The speed limit is 10 km/h and other limits are not permitted
- The Shared Zone may consist of a network of roads or a single road
- The Shared Zone may include laneways
- The driving environment for motorised vehicles shall be such that vehicle-operating speeds are generally no more than 10 km/h
- Raised kerbs shall be removed to provide visual cues to drivers that pedestrians have right of way
- The surface texture of the shared zone shall be different from the surrounding road network
- Entrance and exit widths shall be narrowed so that there is a physical entry and exit to the zone
- Each road shall have a trafficable width of at least 2.5 m for one-way traffic and 4.5 m for two-way traffic
- There shall be minimal turning and intersecting motorised vehicular traffic
- The roads shall have significant physical interruption to vehicular traffic by the use of bollards, parallel parking bays, plants and landscaped areas
- There shall be minimal need for reversing of motorised traffic in entering and departing parking bays (Angle and 90° kerbside parking are not desirable)
- Parking spaces and loading zones, where provided, shall be located adjacent to the trafficable path and clearly signed and marked
- The shared zone shall be an integral part of an agreed traffic management plan for the area that was developed with community consultation
- Service and Emergency vehicles shall be able to use all roads
- All roads within the area shall meet the definition of a built-up area and have street lighting to Category P as defined in AS/NZS1158.3.1 – 2005

For detailed drawings and measurements refer to AS1742.4-2008-Typical shared zone treatment (Figure 3.2)

11.3.2 Roadways and Parking

The road should be discontinuous and kerbs should be removed to enhance the sense of pedestrians having right of way over vehicles. The use of different coloured paving and other visual cues should be included for pedestrians with disability.

The preferred traffic flow for shared zones is one-way as the narrow trafficable width discourages higher speeds. A minimum trafficable width of 3 m (one-way traffic) should be maintained throughout the zone (absolute minimum of 2.5 m)

Shared zones with two-way traffic may be acceptable where suitable traffic calming measures are in place.



There should be no provision for traffic to flow across the zone except under special circumstances where there is no other reasonable alternative access.

Parking spaces and loading zones, where provided, must be located adjacent to the trafficable path and clearly signed and marked.

11.3.3 Traffic Calming in Shared Zones

A shared zone should create a feeling of visual enclosure from the rest of the road network by narrowing the entrance and exit widths so that there is a physical entry / exit to the zone.

Where pedestrian volumes are low, speed reduction devices should be installed at a spacing of approximately 40 m and these should be staggered on opposite sides of the carriageway to create a weaving alignment through the shared zone. Devices should include planting areas to contain the area visually. Bollards with reflectors may be used to delineate the shape of the roadway on the approach side of landscaping.

It is desirable to create a surface texture difference between the shared zone and the surrounding road network. Perimeter (threshold) treatments, in accordance with AS 1742.13 – 2009, can be considered and are placed at a perimeter of a shared zone to inform road users that they are entering a lower speed environment.

11.3.4 Signs

Signs installed must be in accordance with AS1742.4 – 2008, Section 3.2.6.

Shared Zone Sign

The entry point/s to a shared zone require the installation of a 'shared zone' sign indicating the 10 km/h speed limit.

Repeater Signs

Repeater signs are used within a linear or area speed zone other than at the beginning or end of the zone to confirm the speed limit applying within the zone.

End Shared Zone Sign

The exit point/s of shared zones require the installation of an 'end shared zone' sign.



Shared Zone Sign



End Shared Zone Sign

11.4 Traffic Calming

Objective

To demonstrate measures to reduce the speed of vehicles and provide a safer environment for pedestrians.

Key Points

Traffic calming slows traffic by restricting traffic movements and by changing the environment.

Careful design is required to avoid introducing safety hazards.

Traffic calming is a means of modifying the road to achieve a more desirable coexistence between different transport modes. It uses devices and environmental changes to encourage drivers to travel at slower speeds and thereby create a safer environment for all road users.

Traffic calming is generally self-enforcing. The design of the roadway results in the desired effect without relying on compliance with traffic control devices such as signals and signs.

Although engineering techniques using vertical and horizontal displacements are most effective in reducing vehicle speeds, environmental changes create visual cues that work in conjunction with the physical devices. Environmental changes also improve the ambience of the road for pedestrians making it a more attractive place to be.

Traffic calming in different contexts are detailed in various guides:

- Austroads Guide to Traffic Management Part 8: Local Area Traffic Management
- Austroads Guide to Traffic Management Part 7: Traffic Management in Activity Centres
- For roads controlled by MRWA, refer to the MRWA Guideline for Local Area Traffic Management (D08#102211)



Marine Parade, Cottesloe



James Street, Northbridge

11.4.1 Traffic Management in Activity Centres

There is a particular need to reduce the speed (and volume) of traffic through busy activity centres where there are large numbers of pedestrians crossing the road. The Towards Zero road safety strategy identifies a 30 km/h safe speed threshold for roads where there is greater potential for conflict between cars and unprotected road users (pedestrians and cyclists).

This safe speed environment can be created through a combination of physical and environmental measures to slow traffic, as well as reinforcing the safe speed through lower speed limits. This approach has been adopted in Oxford Street, Leederville, where a 30 km/h linear speed limit was implemented in 2009. Other activity centres in Perth such as the Perth CBD, Northbridge and Fremantle, include permanent 40 km/h area wide speed limits. The average speeds though these precincts are likely to be lower due to traffic calming measures and the number of pedestrian crossing movements.

Austrroads Guide to Traffic Management Part 7: Traffic Management in Activity Centres outlines an approach to dealing with the problems of conflict between through traffic on arterial roads and the needs of the town centres through which they pass.

Sharing the Main Street (RTA NSW, 2000) is a comprehensive guide to the application of the concepts of environmental adaptation to the main streets of towns and suburbs.



Oxford Street, Leederville
30km/h speed reduction



Northbridge
40 km/h area wide speed limit



Victor Harbor, South Australia
Example from AGTM Part 7

11.4.2 Physical and Regulatory Techniques

Lower Vehicle Speeds

- Speed humps, road cushions and raised plateaus
- Centre blister islands
- Angled slow points
- One-way slow points
- Chicanes and driveway links
- Roundabouts
- Speed limit restrictions

Improve Pedestrian Facilities

- Widen footpaths
- Kerb extensions
- Median treatments
- Pedestrian refuges
- Zebra and wombat crossings
- Shared zones

Narrow the Carriageway

- Reduce lane widths
- Indented and angled parking



Carrington Street, Nedlands
Centre Blister



Marine Parade, Cottesloe
Zebra Crossing, Kerb Extensions
and Median Treatment



Newcastle Street
Road Narrowing

Reduce Through Vehicles and Traffic Volumes

- Full, partial and diagonal road closures
- One-way systems
- Turn restrictions and left-in / left-out islands
- Entry statements
- Improvements to adjoining regional roads
- Direction signing
- Modified T-intersection

Reduce Truck Movements

- Load limits
- Rear service roads
- Truck route signing

Visual Techniques

- Avenue and median tree planting
- Low groundcover
- Street furniture
- Swale drains
- Brick paving and coloured asphalt
- Building frontages close to the road



Chelmsford Road, Mount Lawley
(Partial Road Closure)

Note: that debris in the cycle lane at this partial road closure indicates that maintenance is currently below standard

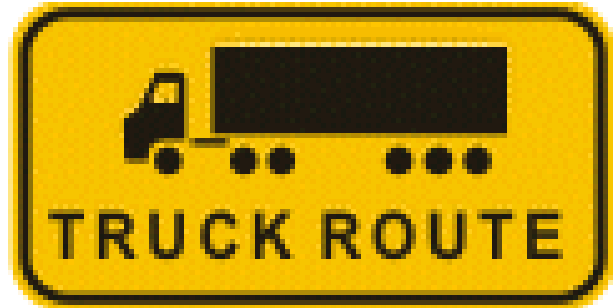

Truck Route Sign (MR-WM-45)



James Street and Lake Street, Northbridge

11.4.3 Precautions

Care is required in the design of traffic calming schemes to ensure that the safety of some road users is not compromised by introducing hazards. Designers should be aware of the following issues:

- Bushes and low trees can restrict sight lines between motorists and pedestrians
- Road narrowing measures can introduce squeeze points for cyclists
- Traffic calming devices can be hazardous to motorists if not designed correctly
- Traffic calming can frustrate motorists on roads which have a significant traffic function
- Traffic calming can compromise or deny access to emergency vehicles
- May not be appropriate on bus routes or roads where there is a high number of commercial vehicles



Bicycle Squeeze Point

12. Accessible Car Parking Bays

In this Section

- 12.1 Accessible Car Parking Bays
 - 12.1.1 Design
 - 12.1.2 Directional Signs
 - 12.1.3 Signage
 - 12.1.4 Access to Footpath
 - 12.1.5 Accessible Parking Supply

12.1 Accessible Car Parking Bays

Objective

To instruct on the appropriate design, location and signage to ensure accessible car parking bays are effective for those with mobility impairments

Key Points

Bays to be located near the accessible entrance to the facility that they service

A flat surface must be provided

Dimensions of the bay must allow access to all doors of a car

A clear continuous path of travel must be provided to the adjacent footpath

Accessible car parking bays are for the exclusive use by people with disability. Users are required to have an authorised permit which is issued after the applicant has been assessed as eligible by ACROD.



12.1.1 Design

Location

Accessible bays are to be located as close as possible to the accessible entrance to the facility that they service.

Safety

If the position is considered unsafe, other locations should be considered.

Any position may be considered unsafe if a driver or carer is required to transfer or unload a wheelchair into potentially dangerous traffic flows.

Dimensions

Dimensions are to comply with AS/NZS2890.6 – 2009 Parking Facilities Part 6: Off-street parking for people with disability.



Hospital Avenue, Nedlands

Note: AS/NZS2890.6-2009 requires the line markings defining the edge of the accessible bay to be yellow

Angle Parking Bays

For angled spaces between 45 and 90 degrees, accessible bays must be a minimum of:

- 2.4 m wide by 5.4 m long for parking spaces (wider if possible)
- An additional shared space 2.4 m wide by 5.4 m long on one side of the parking space (can be provided as footpath or shared with adjacent parking space)
- A clear area of 2.4 m wide by 2.4 m long at the front or rear of the parking space. This can be part of the adjacent roadway, but will cause ramps to block the roadway when they are in use. Providing longer bays wherever possible will address this issue.

Overhead Clearance

A minimum headroom of 2.5 m is required for the dedicated car parking spaces to allow use of a car top hoist. A minimum headroom of 2.2 m is required along the vehicular travel path from the car park entrance/exit to the car parking spaces.

Parallel Parking Bay

For parallel spaces, accessible bays must be a minimum of:

- 3.2 m wide by 7.8 m long for parking spaces
- Include an additional shared space 1.6 m wide by 7.8 m long on the non-trafficked side of the parking space (can be provided as footpath)

Surface

Accessible bays must be located on level firm surfaces with falls no greater than 1:33 on an outside bituminous seal. A maximum 1:40 fall is permitted for all other circumstances.

This flat surface should continue at the rear of the bay to allow transference of wheelchairs from the rear of cars.

These areas shall have a slip-resistant surface.

Pavement Markings

Ground markings such as the lines and the stencilled international access symbol are to be well maintained.

Line markings are to be in yellow and have a slip resistant surface. Raised pavement markers are not to be used for space delineation.

Each accessible bay is to be identified by the international symbol of access. The symbol is to be white on a blue background; the blue colour is B21, ultramarine, in accordance with AS2700 – 2011, or similar. Dimensions and placing of the symbol is to be in accordance with AS/NZS2890.6 – 2009 (Clause 3.1).



Milligan Street, Perth

Note: The markings in this parallel parking bay do not meet AS/NZS2890.6

For detailed drawings and measurements refer to AS/NZS2890.6-2009-Use of Symbol of Access to Identify Spaces (Figure 3.1) and AS1428.1-2009 (Figure 10)

12.1.2 Directional Signs

If an accessible bay is not visible to a driver entering a carpark, directional signage should be used. The international access symbol in combination with an arrow pointing to the accessible bay is required. The international access symbol should face the direction of intended travel.



12.1.3 Signage

Above ground signs at accessible bays should incorporate the international access symbol, a white stylised wheelchair on a blue background. These signs should be used in addition to the pavement markings where the spaces are provided solely for the use of ACROD permit holders. Signs should not be located in positions which prevent passenger doors from being opened.



Melville Recreation Centre

12.1.4 Access to Footpath

Provide a clear and uninterrupted path of travel from the parking bay, via a kerb ramp to the adjacent footpath. An accessible path of travel needs to be a minimum of 1.2 m wide.



Floreat Beach

12.1.5 Accessible Parking Supply

The Building Code of Australia (BCA) sets out the minimum supply rates for accessible parking bays. Additional accessible parking bays should be supplied where there is likely to be a larger demand than the minimum rates set out in the BCA.

Facility	Number of accessible parking bays
Retail	1 space for every 100 car parking spaces (or part thereof)
Commercial	Up to a total of 1000 car parks: 1 space for every 50 car parking spaces (or part thereof) For each additional 100 car parks in excess of 1000: 1 space per 100 car parks
Schools	1 space for every 100 car parking spaces (or part thereof)
Hospital: <ul style="list-style-type: none"> <li data-bbox="159 817 406 851">• Outpatient areas <li data-bbox="159 907 470 940">• Non-outpatient areas 	Up to a total of 1000 car parks: 1 space for every 50 car parking spaces (or part thereof), For each additional 100 car parks in excess of 1000: 1 space per 100 car parks 1 space for every 100 car parking spaces (or part thereof)
Aged Care Facility	1 space for every 100 car parking spaces (or part thereof)

Minimum provision of parking bays for people with disability - adapted from the BCA- Table D3.5

13. Abbreviations

Abbreviation	Definition
AS	Australian Standard
AS/NZS	Australian Standard / New Zealand Standard
AGRD	Austrroads Guide to Road Design
AGTM	Austrroads Guide to Traffic Management
BCA	Building Code of Australia
DSC	Disability Services Commission
km/h	kilometres per hour
LoS	Level of Service
MRWA	Main Roads Western Australia
PAW	Pedestrian Access Ways
PTA	Public Transport Authority
PSP	Principal Shared Path
TGSI	Tactile Ground Surface Indicator
TMR	Department of Transport and Main Roads (Queensland)
WAPC	Western Australia Planning Commission
m	metre
mm	millimetre
vpd	vehicles per day

14. References

- Australian Local Government Association, National Heart Foundation of Australia and Planning Institute of Australia, 2009 Healthy Spaces and Places: A national guide to designing places for healthy living, Planning Institute of Australia, Canberra, ACT.
- Austroroads, 2006, Pedestrian-Cyclist Conflict Minimisation on Shared Paths and Footpaths, Research Report, Austroroads, Sydney, NSW.
- Austroroads, 2007, Guide to Traffic Management - Part 6: Intersections, Interchanges and Crossings, Austroroads, Sydney, NSW.
- Austroroads, 2008a, Guide to Traffic Management – Part 5: Road Management, Austroroads, Sydney, NSW.
- Austroroads, 2008b, Guide to Traffic Management – Part 8: Local Area Traffic Management, Austroroads, Sydney, NSW.
- Austroroads, 2009a, Guide to Road Design – Part 4: Intersections and Crossings - General, Austroroads, Sydney, NSW.
- Austroroads, 2009b, Guide to Road Design – Part 4C: Interchanges, Austroroads, Sydney, NSW.
- Austroroads, 2009c, Guide to Road Design – Part 6A: Pedestrian and Cyclist Paths, Austroroads, Sydney, NSW.
- Austroroads, 2009d, Guide to Traffic Management – Part 4: Network Management, Austroroads, Sydney, NSW.
- Austroroads, 2009e, Guide to Traffic Management – Part 7: Traffic Management in Activity Centres, Austroroads, Sydney, NSW.
- Austroroads, 2010, Guide to Road Design – Part 4A: Unsignalised and Signalised Intersections, Austroroads, Sydney, NSW.
- Austroroads, 2011, Guide to Road Design – Part 4B: Roundabouts, Austroroads, Sydney, NSW.
- Australian Building Codes Board, 2011, Building Code of Australia –Volume 1, Canberra, ACT.
- Commonwealth of Australia, 1992, Disability Discrimination Act 1992, amended 2009, Attorney General's Department Canberra, ACT www.comlaw.gov.au/Details/C2010C00023
- Commonwealth of Australia, 2011, National Disability Strategy 2010 – 2020, 2011, An initiative of the Council of Australian Governments, Canberra, ACT.
- Department for Planning and Infrastructure, 2006, Transport Assessment Guidelines for Developments Volume 3 –Subdivisions, Western Australia Planning Commission, Government of Western Australia, Perth, WA.
- Department for Planning and Infrastructure, 2006, Transport Assessment Guidelines for Developments Volume 5 – Technical Appendix, Western Australia Planning Commission, Government of Western Australia, Perth, WA.
- Department for Planning and Infrastructure, 2007 (2009 update 02), Liveable Neighbourhoods – a Western Australian Government sustainable cities initiative, Western Australian Planning Commission, Government of Western Australia, Perth, WA.
- Department for Planning and Office of Crime Prevention, 2009a, Procedure for the Closure of Pedestrian Access Ways, Western Australia Planning Commission, Government of Western Australia, Perth, WA.
- Department for Planning and Office of Crime Prevention, 2009b, Reducing Crime and Anti- Social Behaviour in Pedestrian Access Ways Planning Guidelines, Western Australia Planning Commission, Government of Western Australia, Perth, WA.
- Department for Transport, 2007, Manual for Streets, Thomas Telford Publishing, London, UK.

- Department for Transport, 2011, Walkability Audit Tool, Government of Western Australia, Perth, WA <http://www.transport.wa.gov.au/>
- Department of Planning, 2010, Directions 2031 and beyond – metropolitan planning beyond the horizon, Western Australian Planning Commission, Government of Western Australia, Perth, WA.
- Department of Planning, 2010, State Planning Policy, 4.2, Activity Centres for Perth and Peel, Government Gazette, No. 166, Perth, WA www.planning.wa.gov.au/publications/1178.asp
- Department of Premier and Cabinet, Main Roads Act 1930, Western Australian Legislation, Government of Western Australia, State Law Publisher, Perth, WA.
- Department of Premier and Cabinet, Road Traffic Code 2000, Western Australian Legislation, Government of Western Australia, State Law Publisher, Perth, WA www.slp.wa.gov.au
- Disability Services Commission, 1996 updated 2011 , Access Resource Kit Creating Accessible Communities – with checklists to improve access for people with disabilities, Disabilities Services Commission, Government of Western Australia, Perth, WA.
- Disability Services Commission, 2009, Count Me In – Disability Future Directions, A better future for everyone, Disability Services Commission, Government of Western Australia, Perth, WA.
- Institute of Transport Engineers, 2010, Context Sensitive Solutions, Designing Walkable Urban Thoroughfares: A Context Sensitive Approach, An ITE Recommended Practice, Washington, USA, <http://www.ite.org/css/>
- International Charter for Walking, 2006, WALK21 international conference series, <http://www.walk21.com/charter/>
- Main Roads Western Australia, Pedestrian Crossing Facilities Guidelines 2004 (unpublished), MRWA, Perth, WA.
- Main Roads Western Australia, Standard Drawings Perth, WA. <http://standards.mainroads.wa.gov.au>
- Main Roads Western Australia, 2011, MRWA Guideline for Local Area Traffic Management (D08#102211), Perth, WA. http://www2.mainroads.wa.gov.au/Internet/Standards/RTems/traffic_mgmt/local_area/default.asp
- Main Roads Western Australia, 2010, MRWA Guideline for Pedestrian Signals (D08#6040), http://www2.mainroads.wa.gov.au/Internet/Standards/RTems/traffic_mgmt/signals/pedestrian_signals.asp
- Main Roads Western Australia, MRWA Speed Zone Application and Technical Guidelines (D10#87689 and D10#92683) Perth, WA.
- Main Roads Western Australia, 2011, MRWA Lighting Design Guideline for Roadway and Public Spaces (D09#291515), Perth, WA. http://www2.mainroads.wa.gov.au/Internet/Standards/RTems/roadside/lighting_design_guideline_for_roadway_and_public_spaces.asp
- Metropolis, P., 2007 Guidelines for Road Safety Around Schools, Local Government Edition, RoadWise, WA Local Government Association, Perth, WA.
- Metropolis, P., 2007 Guidelines for Road Safety Around Schools, Schools Edition, RoadWise, WA Local Government Association, Perth, WA.
- Office of Road Safety, 2009, Towards Zero – Road safety Strategy -To Reduce Road Trauma in Western Australia 2008-2020, Office of Road Safety, Government of Western Australia, Perth, WA.
- Premier's Physical Activity Taskforce, 2007. Walk WA: A Walking Strategy for Western Australia 2007 – 2020. Department of Sport and Recreation, Government of Western Australia, Perth, WA.
- Public Transport Authority, 2010, Public Transport Public Transport Bus Stop Site Layout Guidelines. Government of Western Australia, Perth, WA.

Public Transport Authority, 2011, Designing and Planning Guidelines for Public Transport Infrastructure. Government of Western Australia, <http://www.pta.wa.gov.au/PublicationsandPolicies/DesignandPlanningGuidelines/tabid/109/Default.aspx>

Standards Australia, Standards New Zealand, AS/NZS 1158.1.1:2005, Lighting for roads and public spaces - Vehicular traffic (Category V) lighting - Performance and design requirements, Sydney, NSW and Wellington, NZ.

Standards Australia, Standards New Zealand, AS/NZS 1158.3.1:2005, Lighting for roads and public spaces - Pedestrian area (Category P) lighting - Performance and design requirements, Sydney, NSW and Wellington, NZ.

Standards Australia, Standards New Zealand, AS/NZS 1158.4:2009, Lighting for roads and public spaces - Lighting of pedestrian crossings, Sydney, NSW and Wellington, NZ.

Standards Australia, Standards New Zealand, AS/NZS 1428.4.1:2009, Design for access and mobility - Means to assist the orientation of people with vision impairment - Tactile ground surface indicators, Sydney, NSW and Wellington, NZ.

Standards Australia, Standards New Zealand, AS/NZS 2890.6:2009, Parking facilities - Off-street parking for people with disabilities, Sydney, NSW and Wellington, NZ.

Standards Australia, AS 1428.1-2009, Design for access and mobility - General requirements for access - New building work, Sydney, NSW.

Standards Australia, AS 1428.2-1992, Design for access and mobility - Enhanced and additional requirements - Buildings and facilities, Sydney, NSW.

Standards Australia, AS 1742.2-2009, Manual of uniform traffic control devices - Traffic control devices for general use, Sydney, NSW.

Standards Australia, AS 1742.7-2007, Manual of uniform traffic control devices - Railway crossings, Sydney, NSW.

Standards Australia, AS 1742.10-2009, Manual of uniform traffic control devices - Pedestrian control and protection, Sydney, NSW.

Standards Australia, AS 1742.14-1996, Manual of uniform traffic control devices - Traffic signals, Sydney, NSW.

Standards Australia, AS 1742.4-2008, Manual of uniform traffic control devices - Speed controls, Sydney, NSW.

Standards Australia, AS 5100.1-2004, Bridge design - Scope and general principles, Sydney, NSW.

Transport and Main Roads, 2010, Pedestrian Crossing Facility Guidelines and Prioritisation System User Guide, Queensland Government, Brisbane, Qld.

WA Local Government Association, Roadwise Community Road Safety Program and Resources, <http://www.roadwise.asn.au/resources>

Western Australia Planning Commission, 2006a, Designing Out Crime Planning Guidelines, Government of Western Australia, Perth, WA.

Western Australia Planning Commission, 2006b, Policy Development Control Policy 1.6 - Planning to Support Transit Use and Transit Orientated Development, Government of Western Australia, Perth, WA.

Western Australia Police, Children's Crossings, Government of Western Australia, Perth, WA <http://www.police.wa.gov.au/Traffic/Childrenscrossings/tabid/1524/Default.aspx>